

CBI6024A

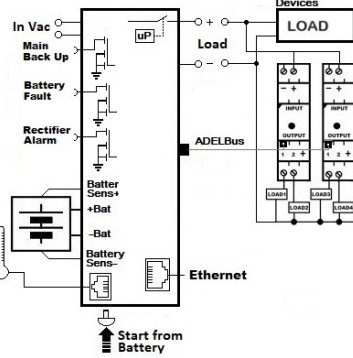

Input: Single-phase 115 - 230 - 277 Vac
Output Selectable Load: 24Vdc 2.5A
Output Battery charging: 24 Vdc 2.5A
 Suited for the following battery types: Open Lead Acid, Sealed Lead Acid, lead Gel, Ni-Cd, Li-Ion
 Automatic diagnostic of battery status, Battery Life test function (internal Battery Impedance)
 Charging curve IUoU, constant voltage and current
 Four charging levels: Boost, Bulk, Trickle, Recovery
 Protected against short circuit and inverted polarity
 Signal output for: Battery Fault, Mains, Rectifier fail
 Ethernet: SNMP V3, Modbus TCP/IP, HTTPS
 DIN rail and Wall mount

New revolutionary product, with Ethernet on board provided with protocol connections: HTTP, HTTPS, SNMPv1/2c/3, Modbus TCP/IP. The device also features the ADELBus protocol for connecting other ADELSYSTEM devices.

Power Management: Thanks to the All In One units (DC-UPS), it will be possible to optimize power management. The available power is automatically allocated between load and battery, supplying power to the load is the first priority of the unit, therefore it is not necessary to double the power, because also the power going to the battery will go to the load if the load so requires. The maximum available current on the load output is 3 times the value of the device rated current In.

Battery Care: it is the concept based on algorithms that implement rapid and automatic charging, four charge phases, battery charge optimization during time, flat batteries recovery and real time diagnostic during installation and operation. The Real Time Auto-diagnostic system monitors battery faults such as sulfated or shorted battery elements, reverse polarity connection, disconnection of the battery; such faults can be easily detected and removed with the help of Diagnostic Blink Codes or through web server. The continuous monitoring of battery efficiency reduces battery damage risk and allows a safe operation in permanent connection. Each device is suited for all battery types, by means of manual configuration by push button or web server it is possible to set predefined curves for Open Lead Acid, Sealed Lead Acid, Gel, Ni-Cd (option). Five charging levels are pre-programmed (recovery, boost, bulk, absorption, float / trickle charge), but they can be changed by the user. With a rugged casing for DIN rail mounting, IP20 protection degree, the product is extremely compact and cost effective.

Interconnections: The platform communication for ADELSYSTEM devices allows the connection of all components in a simple but very powerful way via Ethernet. Communication is based on various protocols: Modbus TCP/IP, SNMP or HTTP/HTTPS, depending on your application. The CANopen-based ADELBus allows to communicate with all the accessories provided by ADELSYSTEM and to develop an independent system for electrical continuity. At the same time, it allows monitoring and control all parameters in the system, even from the other side of the world, by means of application tools on the cloud. ADELSYSTEM allows you to implement very simple but sophisticated monitoring and control for your energy system and opens your mind to new ways to approach your applications.

Norms and Certifications: The CE mark in conformity to EMC 2014/30/EU: Electromagnetic Compatibility Directive; 2014/35/EU: Low Voltage Directive; ROHS 2011/65/EU: Restriction of the use of certain Hazardous Substances in Electrical and Electronic Equipment (RoHS), as amended by 2015/863/EU. EMC Immunity: EN61000-6-2; EMC Emission: EN61000-6-3. According to: Electrical Equipment for Machinery EN 60204; Electrical safety (of information technology equipment) IEC/EN EN62368-1.

Approval: EN IEC 61010 Safety requirements for electrical equipment for measurement, control and laboratory use.

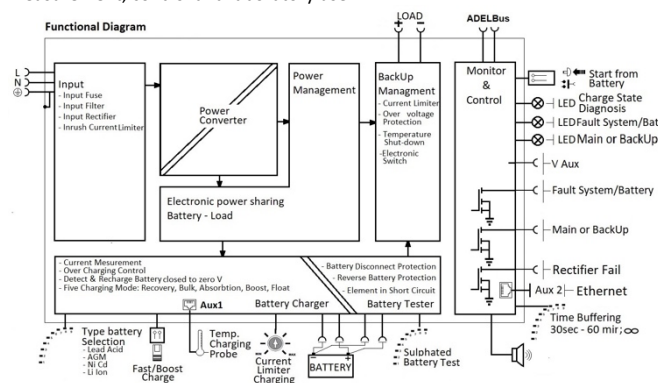

Input Data

Nominal Input Voltage (2 x Vac)	115 – 230 – 277
Input Voltage range (Vac)	90 – 305
DC Input Range (Vdc)	95 – 370
Power Factor typ. (115 – 230 Vac)	0.6 – 0,47
Input Inrush Current Limiter	NTC
Inrush Current (Vn – In nom. Load) I ² t	≤ 10 A ≤ 5 msec.
AC Frequency	47 ± 63 Hz
DC Frequency	0 Hz
Input Current (115 – 230 Vac)	1 – 0.7 A
Internal fuse (not replaceable)	4 A
External Fuse (recommended) MCB curve B	6 A
Input Current (No Load and Alarm)	Input 110Vac Input 230Vac Back Up
Quiescent Current (mA)	24.8 34.0 18.5
Ethernet Enabled (mA)	27.5 34.5 22.5
CAN Enabled (mA)	26 34.5 22.5
ETH+CAN Enabled (mA)	28.5 35 23.7

Output Data

Output Voltage 24 Vdc	24 Vdc
Nominal current I _n	2.5 A ± 5%
Turn-On delay after applying mains voltage	1 sec. (max)
Start up with Strong Load (capacitive load)	Yes, Unlimited
Efficiency (at 50% of rated current)	≥ 83 %
Ripple and Noise (20 MHz Bandwidth)	80 mV _{pp} (max)
Dissipation power load max (W)	6
Start from Battery only, without main	Push Button
Short-circuit protection	Yes
Over Load protection	Yes
Over Voltage Output protection	Yes (typ. 35 Vdc)
Overheating Thermal protection	Yes

Load Output

Output voltage (at I _n)	22 - 28.8 Vdc (31 Vdc Ni-Cd)
Nominal Current I _n	1.1 x I _n A ± 5%
Continuous current (without battery) I _{load} = I _n	2.5 A
Continuous current (With battery) I _{load} = I _n + I _{batt}	2 x I _n
Max. Output Load (Main with Battery) I _{load} = I _n + I _{batt} (4 sec.)	3 x I _n max. (A)
Max. current Output Load (Back Up) I _{load} (4 sec.)	2 x I _n max.
Output On/Off	Yes: Drive by Ethernet
Push Button –Terminal Input "Start from Battery without main"	Yes
Time Buffering; (switch output off without main input)	0.5;2;5;10;15; 20; 30; 45;60;∞

Battery Output

Output Voltage Battery	Follow the Out Load
Boost-Fast charge Configuration 25°C (V/cell).	Lead Acid: 2.4; NiCd:1.51; LiFePO4:3.65; Li-ion: 4.1
Float Charge Configuration 25°C (V/cell)	Lead Acid:2.23;2.25;2.27; 2.3NiCd:1.4; LiFePO4:3.45; Li-ion: 4.1
Min. Time Boost/Fast charge (Typ. at IN)	1 min.
Max. Time Bulk charge (Typ. at IN)	15 h
Min. Time Bulk charge (Typ. At IN)	1 min.
Recovery Charge	2 - 20 V
End of charging Current (Bulk & Absorption charge)	6% of current limiting
Charging current max I _{batt}	In ± 5%
Charging current limiting I _{adj}	10 ÷ 100 % / I _{bat}
Reverse battery protection	Yes
Sulfated battery check	Yes (by Jumper)

Detection of element in short circuit	Yes
Charging Curve automatic: IUoU	5 stage
Fast Charge	Boost /Float
Threshold alarm Battery almost flat	20 – 21 Vdc batt
Protections against total discharge	19 – 20 Vdc batt

Signal Output (Open Collector)

Main or Backup Power (Sink 20 mA max)	ON: 0 Vdc OFF: Vout (Alarm)
Fault Battery / System (Sink 20 mA max)	ON: 0 Vdc OFF: Vout (Alarm)
Rectifier Failure "Device" (Sink 20 mA max)	ON: 0 Vdc OFF: Vout (Alarm)
V Aux: Auxiliary Output Voltage	22 - 28.8 Vdc / 50 mA
Acoustic Buzzer selectable, for:	Alarm features

Signal Input

Battery Start by: Terminal	Terminal Block or Push Button
Temp. Comp. Battery (with external probe)	RJ temp (RJ11)

Digital Input / Output

Communication Protocol (Ethernet)	TCP/IP - SNMP V3 - HTTPS
ADELSBus	CAN

Mechanics Data

Screw type connection torque	0.6 - 0.8 Nm
Connections Input and Output: L, N: 1 Solid and Stranded	1 x 0.05 - 2.5 mm ² (30 – 12 AWG)
Stripping Length 	5.5 – 6.5 mm
Protection class	II
MTBF at 40°C	> 4.300.000 h
Housing material	Polycarbonate
Dimension (WxHxD) DIN 43880	72 x 90 x 62 mm
Weight (approx.)	0.35 Kg

Climatic Data

Ambient temperature (operation)	-25 ÷ +70°C
De Rating T ^a > 55°C	- 2.5%(In) / °C
Ambient temperature Storage	-40 ÷ +85°C
Humidity at 25 °C no condensation	95% to 25°C
Altitude: 0 to 2 000m - 0 to 6 560ft	No restrictions
Altitude: 2 000 to 6 000m - 6 560 to 20 000ft	De-rating 5°C/1000m
Cooling	Auto convention

General Data

Insulation voltage (IN/OUT)	4000 Vac
Insulation voltage (input / ground)	1605 Vac
Insulation voltage (Output / ground)	500 Vac
Protection Class (EN/IEC 60529)	IP20
Reliability: MTBF IEC 61709	> 300.000 h
Pollution Degree Environment	2
Protection class	II

Lifetime Expectancy and MTBF

Life Time Expectancy defines the minimum life expectancy of the device in hours of operation. Being a device designed with electrolytic capacitors, the maximum duration is defined at 15 years - 131,400 h. Any value higher than this is to be considered only as a theoretical duration, calculated to be able to compare devices with each other.

MTBF stands for Mean Time Between Failure, which is calculated according to statistical device failures, and indicates reliability of a device. It is the statistical representation of the likelihood of a unit to fail and does not necessarily represent the life of a product.

The MTBF figure is a statistical representation of the likelihood of a device to fail. A MTBF figure of e.g. 1 000 000h means that statistically one unit will fail every 100 hours if 10 000 units are installed in the field. However, it can not be determined if the failed unit has been running for 50 000h or only for 100h.

Calculated Lifetime expectancy

Ambient temp.	Out Power	115Vac	230Vac
25°C	48 Vdc – 1.25 A	310 000h	345 000h
25°C	48 Vdc – 2.5 A	150 000h	184 000h
40°C	48 Vdc – 1.25 A	90 000h	122 000h
40°C	48 Vdc – 2.5 A	45 000h	65 000h

MTBF SN 29500, IEC 61709

Ambient temp.	Out Power	115Vac	230Vac
25°C	48 Vdc – 2.5 A	640 000h	683 000h
40°C	48 Vdc – 2.5 A	350 000h	380 000h