



PFC750

750 WATT AC-DC BRICK PFC MODULE

Features

- Universal Input Range 90~264Vac
- Efficiency up to 96.5%
- Half-Brick Size
- Approval Safety IEC/EN/UL 62368-1
- Operating Altitude 5000m
- 750W Active Power Factor Correction (APFC)
- Fixed Switching Frequency
- Brown-In/Out Protection
- Over Temperature Protection
- Over Voltage Protection
- Baseplate Cooling



MODEL NUMBER	OUTPUT VOLTAGE	OUTPUT CURRENT NOTE1	VOLTAGE ACCURACY NOTE2	LINE REGULATION NOTE3	LOAD REGULATION NOTE4	%EFF. (Typ.) NOTE5
PFC750	390 V	1.923 A	±2%	±0.5%	±2%	96.5%

Note:

1. External components are required, please refer to the application note.
2. Voltage accuracy is set at 100% load.
3. Line regulation is measured from 90V_{ac} to 264V_{ac} with full load.
4. Load regulation is measured from 100% to 10% full load.
5. Typical efficiency at 230 Vac and full load at 25°C.
6. When the temperature of brick aluminum case reaches 100°C, the unit will be in OTP. It needs sufficient convection and heat sink.



TECHNICAL SPECIFICATIONS

(All specifications are typical at nominal input, full load at 25°C unless otherwise noted.)

ABSOLUTE MAXIMUM RATINGS

PARAMETER	NOTES and CONDITIONS	Device	Min.	Typ.	Max.	Units
Input Voltage		All	90		264	V _{ac}
Operating Case Temperature	At the center of base plate	All	-40		100	°C
Storage Temperature		All	-40		105	°C
Operating Altitude		All			5000	m

INPUT CHARACTERISTICS

PARAMETER	NOTES and CONDITIONS	Device	Min.	Typ.	Max.	Units
Operating Voltage Range		All	100		240	V _{ac}
Input Frequency Range		All	47		63	Hz
Maximum Input Current	100% Load, V _{in} =100V _{ac}	All			10	A
Inrush Current	V _{in} =240V _{ac} , Cold Start at 25°C (External inrush resistor 10Ω)	All			35	A
Brown-Out Protection		All	65	73	81	V _{ac}
Power Factor	115V _{ac} /230V _{ac} @ Full load	All	0.92		0.99	

OUTPUT CHARACTERISTICS

PARAMETER	NOTES and CONDITIONS	Device	Min.	Typ.	Max.	Units
Output Voltage Set Point	V _{in} =115V _{ac} and 230V _{ac} , I _o =I _o max, T _c =2°C	All	382.2	390	397.8	V _{dc}
Operating Output Current Range	V _{in} =115V _{ac} and 230V _{ac} , T _c =25°C	All			1.923	A
Holdup Time	V _{in} =115V _{ac}	All		8		ms
Load Regulation	100% Load to 10% load	All			±2.0	%
Line Regulation	V _{in} =Low Line to high line	All			±0.5	%
Over Voltage Protection	Auto recovery	All	410		425	V _{dc}
Load Capacitance	1. Ambient temperature=25°C 2. Input voltage is 115V _{ac} and 230V _{ac} 3. Output is max. load	All	660		2200	uF

EFFICIENCY

PARAMETER	NOTES and CONDITIONS	Device	Min.	Typ.	Max.	Units
Efficiency	1. Output is rated load 2. Ambient temperature=25°C @ Input voltage is 230V _{ac}	All		96.5		%

ISOLATION CHARACTERISTICS

PARAMETER	NOTES and CONDITIONS	Device	Min.	Typ.	Max.	Units
Input to Earth (Ground)	1 minute (Without dielectric breakdown)	All			3000	V _{ac}
Output to Earth (Ground)	1 minute (Without dielectric breakdown)	All			3000	V _{ac}

FEATURE CHARACTERISTICS

PARAMETER	NOTES and CONDITIONS	Device	Min.	Typ.	Max.	Units
Switching Frequency	Fixed	All		120		kHz



PFC750

GENERAL SPECIFICATIONS

PARAMETER	NOTES and CONDITIONS	Device	Min.	Typ.	Max.	Units
MTBF	$I_0=100\%$, $T_a=25^\circ\text{C}$ per MIL-HDBK-217F	All		674		k hours
Humidity	Non-Condensing	All			93	% RH
Shock	Meets MIL-STD-810F Table 516.5, Table 516.5-I 10ms, each axis 3 times ($\pm X$ · $\pm Y$ · $\pm Z$ axis)	All		75		g
Vibration	Meets MIL-STD-810F Table 514.5C-VIII, 15~2000Hz, X · Y · Z axis, 1hr (each axis), total 3 hrs.	All		4		g
Weight		All		95		grams
Dimensions		All	2.28x2.40x0.50 inches (57.9x61.0x12.7 mm)			
Case Material	Plastic DAP UL 94V-0					
Base Plate Material	Aluminum Baseplate					
Potting Material	UL 94V-0					
Safety	IEC/EN/UL 62368-1					
EMC Emission						
Conducted Emission	EN55032:2015+A11: 2020, 47 CFR FCC Part 15					Class A
Radiated Emission	EN55032:2015+A11: 2020, 47 CFR FCC Part 15					Class A
Harmonic Current Emissions	EN61000-3-2: 2019					Class C
Voltage Fluctuations & Flicker	EN61000-3-3: 2013+A1: 2019					
EMC Immunity						
Electrostatic Discharge (ESD)	IEC 61000-4-2: 2008, Air Discharge: $\pm 8\text{kV}$ Contact Discharge: $\pm 4\text{kV}$					Criterion A
Radio-Frequency, Continuous Radiated Disturbance	IEC 61000-4-3: 2020					Criterion A
Electrical Fast Transient (EFT)	IEC61000-4-4: 2012, $\pm 1\text{kV}$, $\pm 2\text{kV}$					Criterion A
Surge	IEC61000-4-5: 2014+A1:2017, L-N: $\pm 1\text{kV}$					Criterion A
	IEC61000-4-5:2014+A1:2017, L-E(ground): $\pm 2\text{kV}$					Criterion B
Conducted Disturbances, Induced by RF Fields	IEC 61000-4-6: 2013+COR1: 2015					Criterion A
Power Frequency Magnetic Field	IEC 61000-4-8: 2009					Criterion A
Voltage Dips	IEC 61000-4-11: 2020, Dip: 30% Reduction, Dip >95% Reduction					Criterion A
Voltage Interruptions	IEC 61000-4-11: 2020, >95% Reduction					Criterion B
Application Note Link						PFC750 App Notes



CHARACTERISTIC CURVE

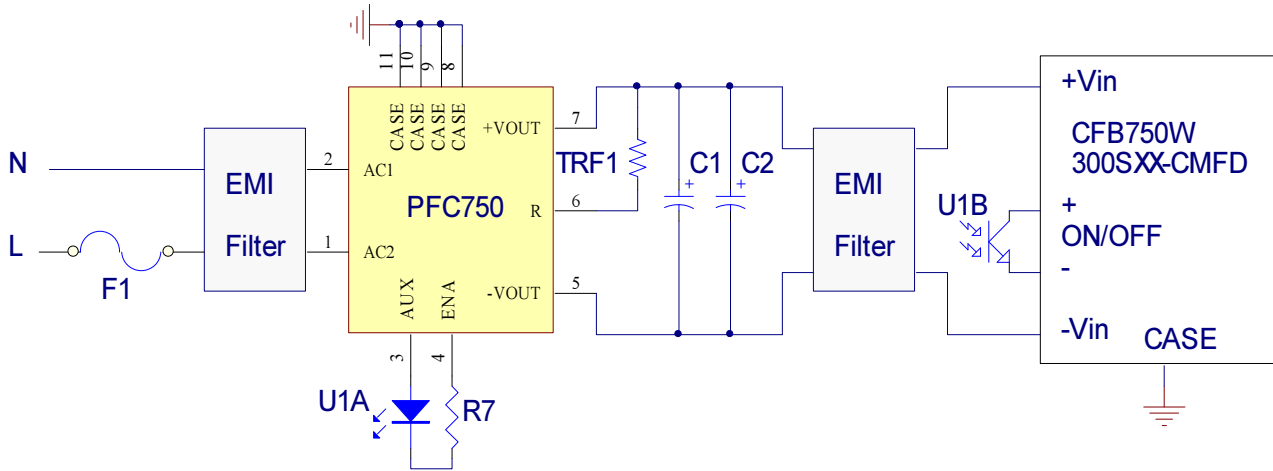

Simplified Application Circuit

Power Derating Curve

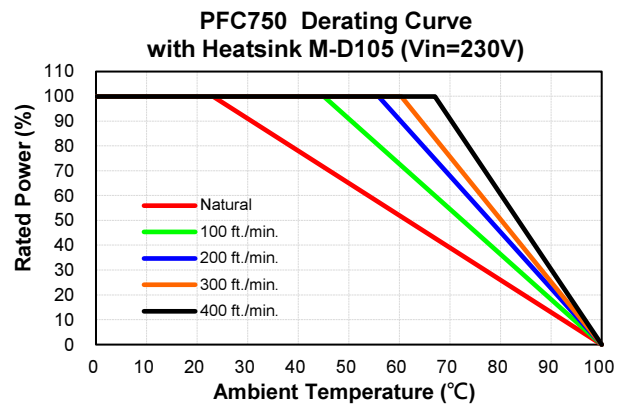
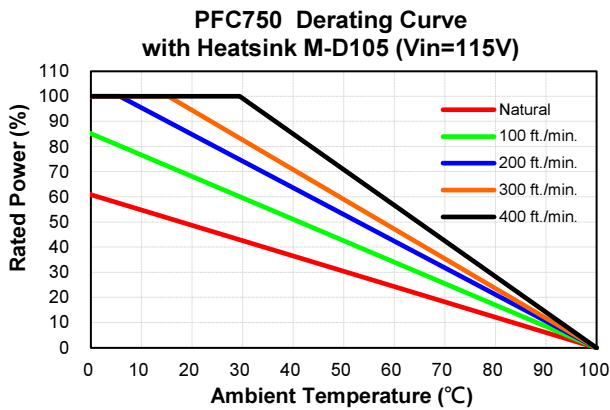

Performance Data

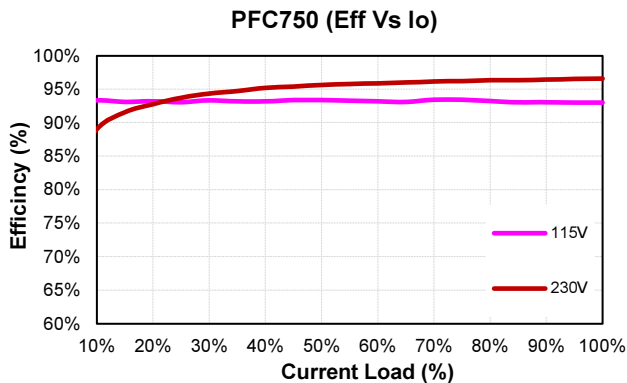



PFC750

MECHANICAL SPECIFICATION

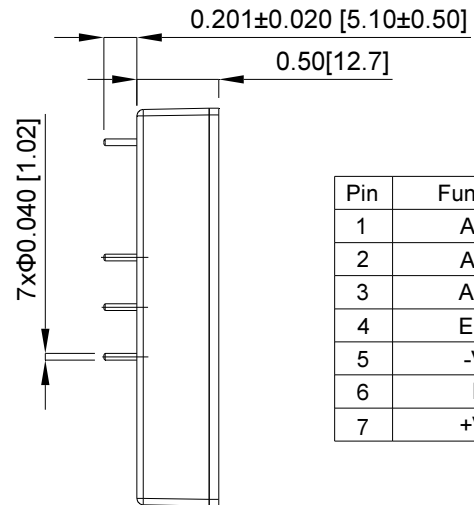
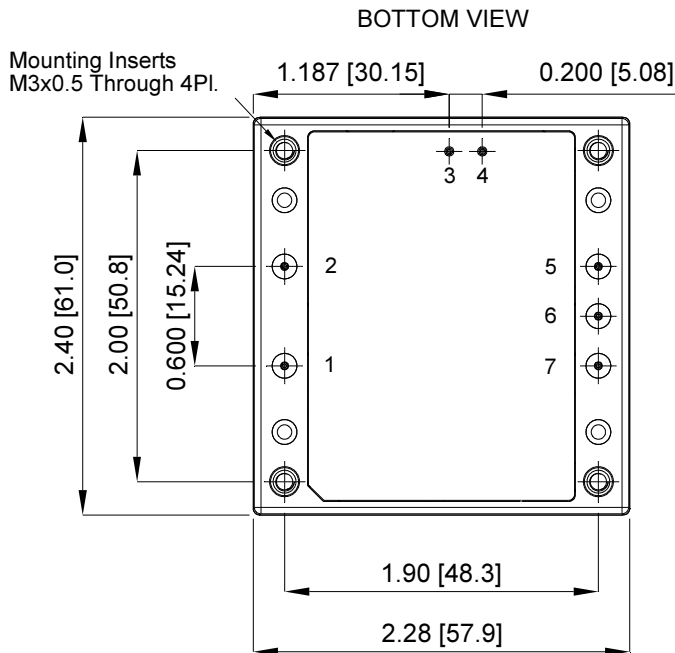

Pin	Function
1	AC1
2	AC2
3	AUX
4	ENA
5	-Vo
6	R
7	+Vo

All Dimensions in Inches[mm]
 Tolerances Inches:x.xx= ± 0.02, x.xxx= ± 0.010
 Millimeters:x.x= ± 0.5, x.xx= ± 0.25