

ODX-6000

6000 VA DC/AC INVERTER

GENERAL FEATURES:

- Sine wave output voltage
- Suitable for motors control
- Adjustable output frequency
- Adjustable output voltage
- High input-output isolation 3000 V_{rms}
- Remote off opto-coupled
- Alarm by isolated relay contacts
- Configurable input: Reverse or Mid power
- Remote control via RS232
- CAN BUS (optional)
- Parallelable output (optional)
- Railway version EN50155 (optional)
- Fire and smoke: EN45545-2 approved



	24 V _{dc} 16.8 ... 30V	48 V _{dc} 33.6 ... 60V	72 V _{dc} 50.4 ... 90V	110 V _{dc} 77 ... 138V
400 V _{ac}	ODX-6000-7502 3500 W	ODX-6000-7505 6000 W	ODX-6000-7506 6000 W	ODX-6000-7507 6000 W

Specifications are subject to change without notice. These products are not intended for use as critical components in life support or nuclear systems. **Compliance notice** – This product has been individually tested and verified to meet the standards and directives listed in this datasheet. When used as part of an equipment or system, verification of the final equipment compliance lies with the integrator/customer. In particular, when operating multiple units in parallel to increase total power, the integrator/customer must ensure that all applicable system-level requirements (e.g., EMC, safety, or any other applicable) are met, including any additional assessment required.

**INPUT**

Input voltage range	-30, +25% $V_{in\ nom}$
Maximum input ripple	5% $V_{in\ nom}$ (V_{rms} , 100 Hz)

OUTPUT

Nominal output voltage (V_{on})	See table
Output voltage range	20...100% of V_{on} (adjust via remote control)
Output frequency	50 / 60 Hz via DIP-switch, 5...75 Hz via RS-232
Load regulation	< 4.5%
Line regulation	< 2% V_{in} -25% ... +25% < 10% V_{in} -30% ... +30% < 20 % V_{in} -40 % ... +40 % (100ms)
Output wave distortion THD	< 2% (average of 16 samples)
Output HF ripple	< 2.5%

ENVIRONMENTAL

Storage temperature	-40 ... 80 °C
Operating temperature: Full load	-40 ... 55 °C (EN50155 OT2)
Operating temperature: 62.5 % load	-40 ... 70 °C (EN50155 OT4)
Relative humidity without condensation	5 ... 95%
Maximum altitude	2000m at full load, 2500m at 95% of load
Cooling	Controlled internal fan
Shock and Vibrations according to	EN61373:2011 Category 1 Class B body mounted
MTBF (MIL-HDBK-217-E; Gb, 25°C)	100.000 h

EMC

Immunity according	EN61000-6-2, EN50121-3-2
Emissions according	EN61000-6-4, EN50121-3-2

SAFETY

Dielectric strength: Input /output	3000 V_{rms} / 50 Hz / 1 min
Dielectric strength: Output / Earth	1500 V_{rms} / 50 Hz / 1 min
Dielectric strength: Input / Earth	500 V_{rms} / 50 Hz / 1 min
Safety according to	EN60950-1, EN62368-1
Fire and smoke	EN45545-2 approved (only for option T , railway version)

MECHANICAL

Weight	< 8950 g
Protection degree	IP20

PROTECTIONS

Against overloads	Current and I^2T limited (see overload protection curve)
Against over-temperature	Shutdown with auto-recovery

CONTROL

Output OK LED	Green
Input OK LED	Green
Alarm LED	Red
Input alarm	Open when alarm. Maximum rating: 0.16 A at 160 V_{dc}
Output alarm	Open when alarm. Maximum rating: 0.16 A at 160 V_{dc}
Remote OFF input	OFF applying 15...143 V_{dc} (acc. to EN50155), Impedance > 35 k Ω
Configurable input (reverse or mid-power)	ON: applying 15...143 V_{dc} (acc. to EN50155), Impedance > 35 k Ω

Note-1: Is not recommended to handle connectors below -25°C



ORDERING CODES

Model	Input voltage DC [V]	Input voltage range [V]	Max. Input current [A]	Output voltage AC [V]	Output current [A]	Active output power [W]	Appar. output power [VA]	Output peak current		Efficien. [%]	No load input current [A]
								5s (rms) [A]	(lopk) 10ms [A]		
ODX-6000-7502	24	16.8 - 30	232	400	6.50	3500	4500	7.8A	20	91.0	1.70
ODX-6000-7505	48	33.6 - 60	191	400	8.66	6000	6000	11.5	20	93.6	0.85
ODX-6000-7506	72	50.4 - 90	127	400	8.66	6000	6000	11.5	20	94.3	0.58
ODX-6000-7507	110	77 - 138	83	400	8.66	6000	6000	11.5	20	94.2	0.38

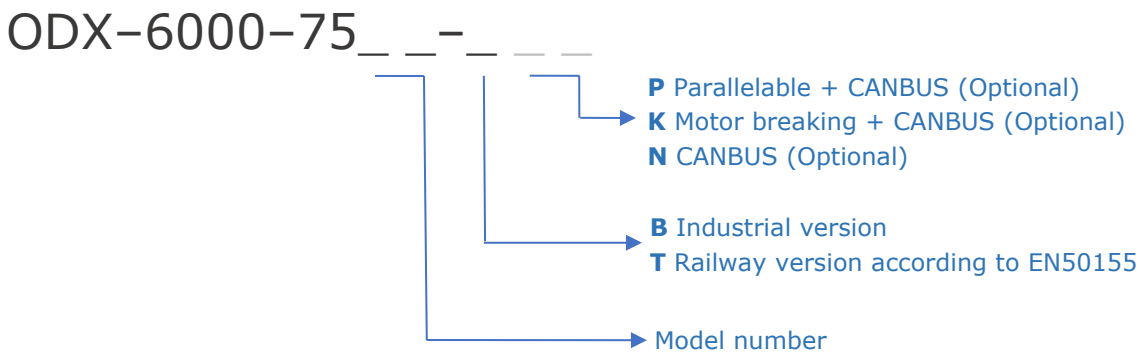

Option P (Parallelable) includes CANBUS port.

Option K (Motor breaking) allows a motor to slow down faster. It includes internal resistors to dissipate energy from the motor; up to 1200 W_{pk} and 800 W for 5 s. This option includes CANBUS port.

Please check availability for P, K or N options

Accessories must be ordered in a separate order line.



BLOCKS DIAGRAM

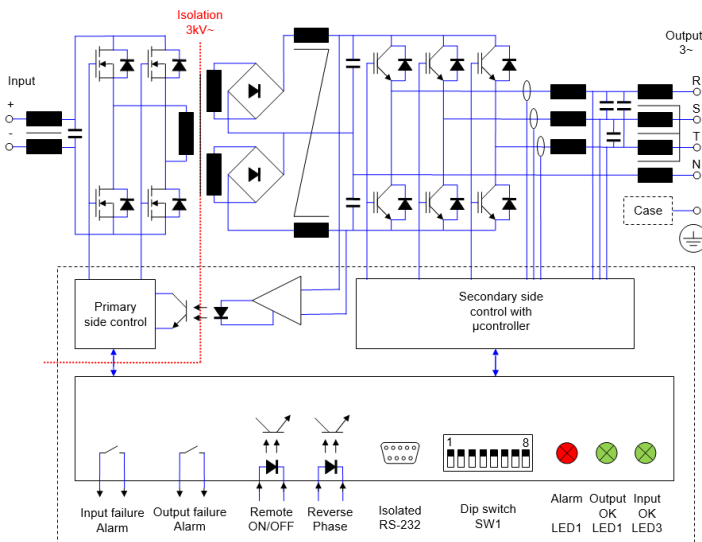

CONNECTIONS

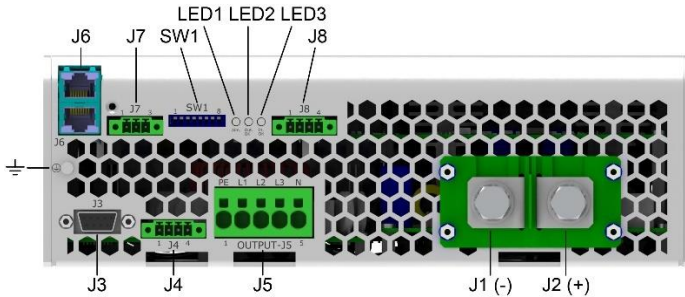

J1	-Vin	Terminal M8 (Max 4.8 Nm)
J2	+Vin	
J5 - 1	Protective Earth	Cables 2.5 ... 4 mm ²
J5 - 2	Output R	
J5 - 3	Output S	
J5 - 4	Output T	
J5 - 5	Output Neutral	Phoenix Contact MC1.5/4-GF-3.81 Recommended female: Phoenix Contact MC1.5/4-STF-3.81
J4 - 1	+ Configurable input	
J4 - 2	- Configurable input	
J4 - 3	+ Remote	
J4 - 3	+ Remote	Phoenix Contact MC1.5/3-GF-3.81 Recommended female: Phoenix Contact MC1.5/3-STF-3.81
J4 - 4	- Remote	
J8 - 1, 2	Output alarm	Female D-Sub DB9
J8 - 3, 4	Input alarm	
J7 - 1	CAN L (optional Can bus)	R145
J7 - 2	CAN H (optional Can bus)	
J7 - 3	GND CAN	Female D-Sub DB9
J3 - 2	RS-232 Rx	
J3 - 3	RS-232 Tx	
J3 - 5	RS-232 GND	
J3 rest	Not connected	
J6A - J6B	Optional Parallel operation	
SW1 - 1	Master / Slave	ON (down): Slave
SW1 - 2	Parallel / Stand alone	ON (down): Stand alone
SW1 - 6	Local / Remote	ON (down): Remote
SW1 - 7	50 Hz / 60 Hz	ON (down): 60 Hz
SW1 rest	Not used	

POWER DERATING vs AMBIENT TEMP.

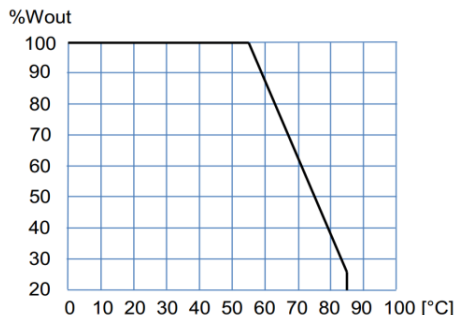

DESCRIPTION

The ODX-6000 consists of three phase sine-wave DC-AC inverters with II isolation between input and output.

The unit allows:

- Changing the output frequency by means of DIP-switch-7 of SW1. OFF: 50 Hz or default programmed, ON: 60 Hz
- Change local/remote (waiting RS-232 commands) by means of DIP-switch-6 of SW1. OFF: local, ON: remote
- Shutdown applying voltage output 15 to 143 V_{dc} on pins 3 and 4 of J4
- Start-up motors by means of a soft start. In the start-up, the output voltage rises linearly from 0 V to set voltage and the frequency from the initial to the set one. The start-up ramp slope may be changed via RS-232
- Set the rotation speed of a motor according to the appropriate Voltage/Frequency ratio.
- Configurable input (pin 1 and 2 of J4):
 - Reverse mode: Changing the rotation direction for the next start-up of a motor by applying voltage between 15 and 143 V_{dc}.
 - Mid power mode: Changing the output frequency in V/F mode from nominal to a mid-power frequency by applying voltage between 15 and 143 V_{dc}.
- Monitoring the status of the input and output voltage through the contacts of two separate solid state relays.
- Set and monitor parameters via RS-232.

The ODX-6000 is equipped with a maximum average power protection as well as maximum output peak current protection. This protects the semiconductors even when an output short-circuit occurs. It also features a disable function for input under-voltage, which allows protecting the batteries from harmful discharges.

START-UP

- The unit has 6 threaded holes for the fixation on a mounting surface.
- The unit has internal fans. For an appropriate cooling, the air input and output should be free of elements that cause and an air flow reduction (minimum recommended distance to other objects 90 mm).
- Make connections as shown in the figure.
- The default output frequency is 50 Hz. For 60 Hz simply actuate the dip-switch as indicated in the figure.

For safety reasons, the following requirements must be met:

- Provide the equipment with some kind of protective enclosure that complies with the electrical safety directives in effect within the country where the equipment is installed.
- Include an input fuse with a rating immediately higher than the maximum input current.
- Use cables of adequate cross-section to connect inputs and outputs. The following table lists the maximum currents and the minimum cross-sections for the cables used for each power connection.

	Input 24 V	Input 48 V	Input 72 V	Input 110 V	Output 400 V
Maximum current	232 A	191 A	127 A	83 A	8.7 A
Cable cross-section	150 mm ²	95 mm ²	50 mm ²	25 mm ²	2.5 mm ²



PARALLEL OPERATION

The models 75xxTPN are designed to work in parallel with one unit set as a MASTER and the rest as SLAVES.

For this mode of operation, it is necessary to connect the MASTER/SLAVE port with a cable RJ45 FTP cat 6 (or higher) from J6B of the first unit to J6A of the following, and the last unit J6B to J6A of the first unit in a ring connection.

In addition, it is necessary to interconnect the output port respecting the phase order, as shown in the diagram:

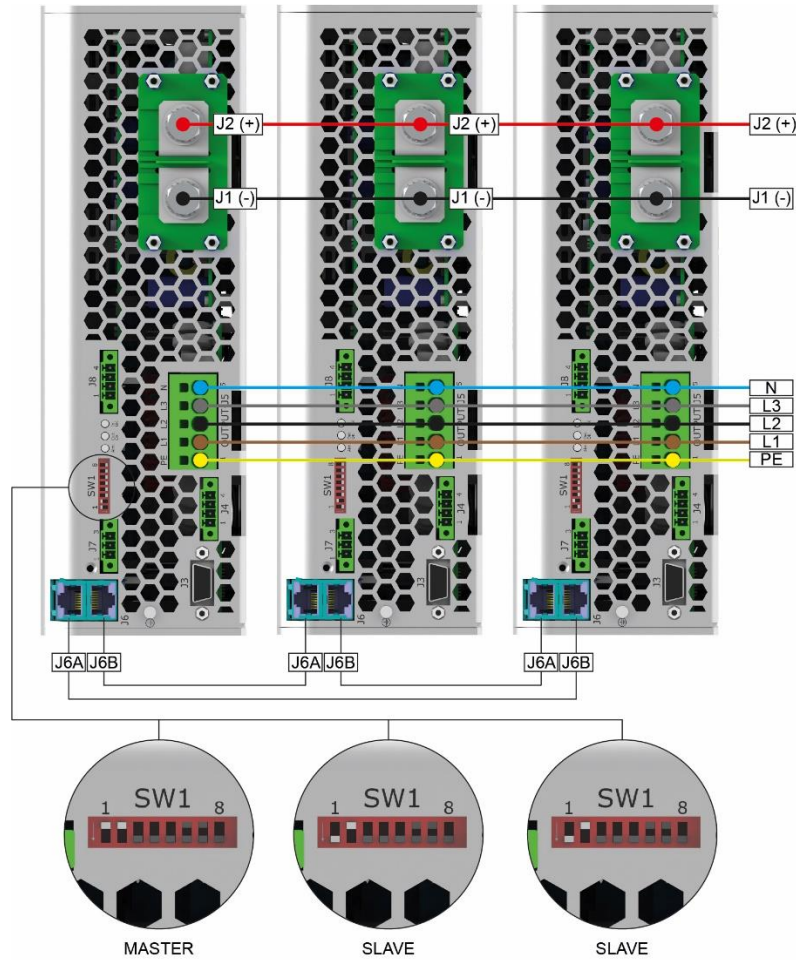

Example for 3 units working in parallel mode

Note: In parallel mode, the Output OK LED is working only in the master unit, the slave unit ever has this LED OFF.

STAND ALONE OPERATION

The models 75xxTPN, can operate stand alone with no connections, setting the dip-switch SW1-1 OFF (MASTER), and SW1-2 ON (Alone) as the diagram show:

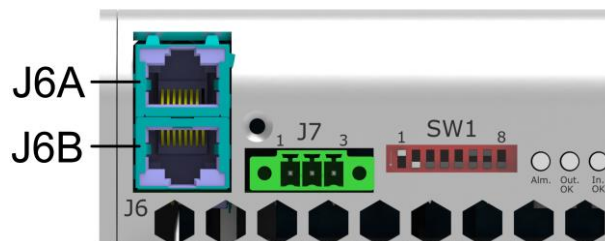



RS232 communication port

It is possible to control and monitor de unit via RS232 by means a terminal emulator like "Tera Term" or "Putty".
Check our guide: <https://premiumpsu.com/wp-content/uploads/2025/09/Serial-Connection-Guide.pdf>



Also it is possible to control and monitor de unit directly using the protocol showed in table:

Protocol configuration: ASCII code, 57600 bauds, parity none, 8 bits, 1bit stop

Header	Function	Parameter	Returns	Explanation		
P	L	V	PTV####	Input voltage in Volts		
		v	PTv####	Input voltage ripple in Volts		
		Y	PTYRN=#### [13]YSN=#### [13]YTN=####	Output voltage in Volts RMS Phase-Neutral ([13] = char 13 of ASCII code)		
		I	PTIR=#### [13]IS=#### [13]IT=####	Output current in Amps RMS ([13] = char 13 of ASCII code)		
		T	PTT####	Internal temperature1 in K		
		t	PTt####	Internal temperature 2 in K		
		F	PTF####	Nominal output frequency in Hz		
		f	PTf####	Actual output frequency in Hz		
		y	PTy####	Actual output voltage set-point in V		
		S	PTS####	Inverter state 999.9 → Enabled 000.0 → Disabled 222.2 → Blocked by overload 111.1 → Blocked by overload or shortcircuit		
		M	PTM####	Model number		
		R	PTR####	Firmware version		
		Other	PTE	Command not supported		
		R	G	1	####	OK / ERR Set the low input voltage timed shutdown in V
	2			####	OK / ERR Set the minimum alarm input voltage in V	
	3			####	OK / ERR Change the status bit (after start up enabled with SW1:6 =LOCAL and disabled with SW1:6 =REMOTE) 999.9 → Inverter enabled 000.0 → Inverter disabled	
	4			####	OK / ERR Set the output voltage Phase-neutral in Vrms (Vo)(output must be stopped) 040.0 ≤ #### ≤ 230.0	
	5			####	OK / ERR Set the maximum output current in Arms 20% I _{nom} ≤ #### ≤ 100% I _{nom}	
	6			####	OK / ERR Set the nominal output frequency in Hz (Fo) (output must be stopped) 005.0 ≤ #### ≤ 075.0	
	7			####	OK / ERR Set the alarm maximum output current 0 < #### ≤ 100% I _{max_warning}	
	8			####	OK / ERR 111.1 → Reset the inverter	
	9			####	OK / ERR Set the number of soft start ramp cycles at initial frequency. 001.0 ≤ #### ≤ 020.0	
	L			####	OK / ERR Set the minimum input starting voltage in Volts V _{in min} ≤ #### ≤ 105% of V _{in nom}	
	O			####	OK / ERR Set the initial frequency in the startup (Fi) 005.0 ≤ #### ≤ 075.0	
	P			####	OK / ERR Set the ramp-up in increment of "N" cycles per Hz in mode V/F, frequency changes or start-up (Note-1) 001.0 ≤ #### ≤ 100.0	
	Q			####	OK / ERR Set the ramp-down in decrement of "N" cycles per Hz in mode V/F (Note-1) 002.0 ≤ #### ≤ 100.0	
	Y			####	OK / ERR Change the working mode of the input J4-1,J4-2 111.1 → Input as reverse phase control (default) 222.2 → Input as mid-power control (Note-2)	
	X			####	OK / ERR Set the mid-power frequency for V/F mode by the use of input J4-1,J4-2 005.0 ≤ #### ≤ 75.0	
	M			1	####	OK / ERR Set a new output frequency in Hz (output must be run and not stored in memory) 005.0 ≤ #### ≤ 075.0
				2	####	OK / ERR Set a new output voltage in Volts (output must be run and not stored in memory) 040.0 ≤ #### ≤ 230.0
				3	####	OK / ERR Set a new output frequency in Hz in mode V/F (output must be run and not stored in memory) 005.0 ≤ #### ≤ 075.0
		4	####	OK / ERR Changes the output phase order (output must be run and not stored in memory) 111.1 → Phase RST (direct phase) 222.2 → Phase SRT (reverse phase)		



CAN communication port (optional)

It is possible to control and monitor the unit using the CAN connection with the CANOpen protocol. It is provided an .eds file with all the objects available.

Protocol configuration: 250kbit/s (N version), 500kbit/s (P version), NODE ID: 1. The most relevant objects can be found in the following table:

Index	Subindex	Name	Type	Attribute	Explanation
0x6001	0x00	Input voltage	UINT32	ro	Input voltage in tenths of Volt
0x6002	0x00	Input Ripple Voltage	UINT32	ro	Input voltage ripple in tenths of Volt
0x6003	0x01	Vrn	UINT32	ro	Output voltage in Volts Phase R-Neutral
0x6003	0x02	Vsn	UINT32	ro	Output voltage in Volts Phase S-Neutral
0x6003	0x03	Vtn	UINT32	ro	Output voltage in Volts Phase T-Neutral
0x6004	0x01	IR	UINT32	ro	Output current in hundredths of Amp Phase R
0x6004	0x02	IS	UINT32	ro	Output current in hundredths of Amp Phase S
0x6004	0x03	IT	UINT32	ro	Output current in hundredths of Amp Phase T
0x6005	0x00	Internal temperature Secondary	UINT32	ro	Internal temperature1 in tenths of K
0x6006	0x00	Internal temperature Primary	UINT32	ro	Internal temperature 2 in tenths of K
0x6007	0x00	Nominal output frequency	UINT32	ro	Nominal output frequency in Hz
0x6008	0x00	Actual output frequency	UINT32	ro	Actual output frequency in Hz
0x6009	0x00	Actual output voltage set-point	UINT32	ro	Actual output voltage set-point in V
0x600A	0x00	Inverter state	UINT16	ro	Inverter state 3 → Enabled 0 → Disabled 2 → Blocked by overload 1 → Blocked by overload or shortcircuit
0x600B	0x00	Product ID	UINT16	ro	Model number
0x600C	0x00	Firmware version	UINT16	ro	Firmware version
0x6100	0x00	Low input voltage timed shutdown	UINT32	rw	Set the low input voltage timed shutdown in tenths of V
0x610B	0x00	Input voltage minimum warning	UINT32	rw	Set the minimum alarm input voltage in tenths of V
0x6101	0x00	AC status bit ¹	UINT8	rw	Change the status bit (after start up enabled with SW3 =LOCAL and disabled with SW3 =REMOTE) 1 → Inverter enabled 0 → Inverter disabled
0x6102	0x00	Nominal output voltage	UINT32	rw	Set the output voltage Phase-neutral in Vrms (Vo) (output must be stopped) $40 \leq x \leq 230$
0x6103	0x00	Maximum output current	UINT32	rw	Set the maximum output current in Arms (per mille) $200\% I_{nom} \leq \text{■■■■} \leq 1000\% I_{nom}$
0x6104	0x00	Nominal frequency	UINT32	rw	Set the nominal output frequency in Hz (Fo) (output must be stopped) $5 \leq x \leq 75$
0x6105	0x00	Alarm maximum output current	UINT32	rw	Set the alarm maximum output current in Arms (per mille) $0\% \leq x \leq 1000\% I_{max_warning}$
0x6106	0x00	Inverter reset ¹	UINT8	wo	1 → Reset the inverter
0x6107	0x00	Minimum starting input voltage	UINT32	rw	Set the minimum input starting voltage in tenths of Volts
0x6108	0x00	Start frequency	UINT32	rw	Set the initial frequency in the startup (Fi) $5 \leq x \leq 75$
0x6109	0x00	Ramp up value	UINT32	rw	Set the ramp-up in increment of "N" cycles per Hz in mode V/F, frequency changes or start-up (Note-1) $1 \leq x \leq 100$
0x610A	0x00	Ramp down value	UINT32	rw	Set the ramp-down in decrement of "N" cycles per Hz in mode V/F (Note-1) $2 \leq x \leq 100$
0x610C	0x00	Soft-start cycles	UINT32	rw	Set the number of soft start ramp cycles at initial frequency $1 \leq x \leq 20$
0x6120	0x00	confi_inversion	UINT8	rw	Change the working mode of the input J4-1,J4-2 0 → Input as reverse phase control (default) 1 → Input as mid-power control (Note-2)
0x6121	0x00	Mid_power_frequency	UINT32	rw	Set the mid-power frequency for V/F mode by the use of input J4-1,J4-2. $5 \leq x \leq 75$
0x6200	0x00	Runtime target frequency	UINT32	wo	Set a new output frequency in Hz (output must be run and not stored in memory) $5 \leq x \leq 75$
0x6201	0x00	Runtime output voltage	UINT32	wo	Set a new output voltage in Volts (output must be run and not stored in memory) $40 \leq x \leq 230$
0x6202	0x00	Runtime frequency V/F	UINT32	wo	Set a new output frequency in Hz in mode V/F (output must be run and not stored in memory) $5 \leq \text{■■■■} \leq 75$
0x6203	0x00	Change phase order	UINT32	wo	Changes the output phase order (output must be run and not stored in memory) 1 → Phase RST (direct phase) 2 → Phase SRT (reverse phase)

Note-1: If AC voltage command (0x6101 -> "AC status bit" to 1) is sent to the unit and then the "inverter reset" is requested (0x6106), it is necessary to send again AC voltage command (0x6101 -> "AC status bit" to 1) to generate the AC voltage at the output.

Note 1:

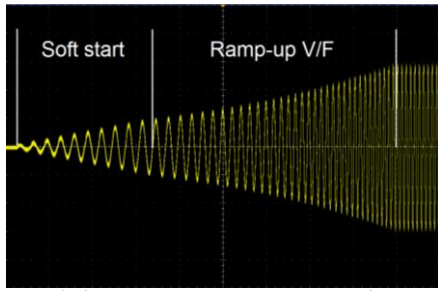

Example for N=1: start-up time = N x 1.7 s for changes from 16 Hz to 50 Hz

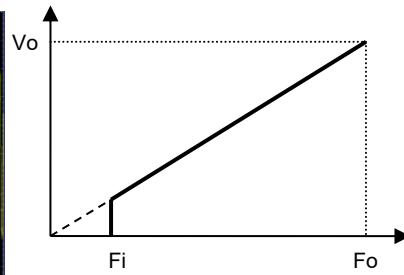

Mode V/F curve

Note 2 :

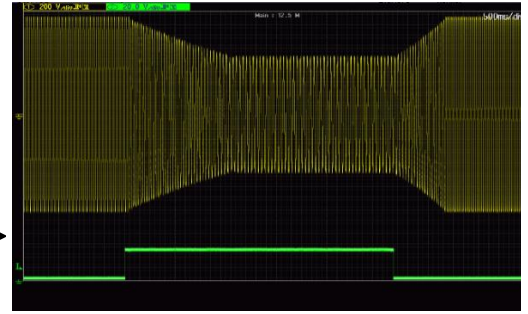

Example for change from 50 Hz / 400 V to 30 Hz and 240V with ramp-down of 2 cycles/Hz and ramp-up de 1 cycle/Hz. Yellow: output voltage and Green: Mid-Power input signal

WORKING PARAMETERS

Thermal protection					
Internal warning temperature (output alarm)			88		°C
Internal shutdown temperature			92		°C
Internal restart temperature			75		°C
Internal temperature of fan start-up			45		°C
Input voltage parameters					
	24 V	48 V	72 V	110 V	
High input voltage shutdown instantaneous	33.6	62.4	93.6	143.0	V _{dc}
High input voltage timed shutdown (t) (Input alarm)	31.2	60.0	90.0	137.5	V _{dc}
<u>Start-up voltage</u>	19.2	38.4	57.6	88.0	V _{dc}
<u>Low input voltage timed shutdown (t)</u> (Input alarm)	16.8	33.6	50.4	77.0	V _{dc}
Low input voltage instantaneous shutdown	14.4	28.8	43.2	66.0	V _{dc}
Time to shutdown (t)	500				ms
Output voltage parameters					
<u>Output voltage phase-neutral</u>	230				V _{ac}
Output under-voltage shutdown	< 85% of setting 1000 ms				
Warning voltage (output alarm)	< 90% of setting 200 ms				
<u>Initial start-up frequency</u>	5				Hz
<u>Soft start duration</u>	1 cycle				
<u>Ramp-up V/F</u>	1 cycle/Hz				
Output current parameters					
<u>Maximum continuous output current</u>	6.52	8.66	8.66	8.66	A
<u>Warning current (output alarm)</u>	6.20	8.22	8.22	8.22	A
Maximum overload I ² t	See figure below				
Time between restart attempts	4000				ms
Number of attempts of consecutive overload	5				
Working failures and reset					
Lock for continuous overload or internal failure	Unlimited time				
Reset time by input disconnection	> 2				min

Configurable parameters underlined

OVERLOAD PROTECTION

Protection against overloads and short-circuits	By current limiting at I _{opk} By I²t . The unit shutdowns when the current-time is over the continuous operation curve	
Overload protection recovery	Every 4 seconds after shutdown, the unit tries to restart up to 5 times. If the overload persists, the unit reminds shutdown until an input reconnection .	

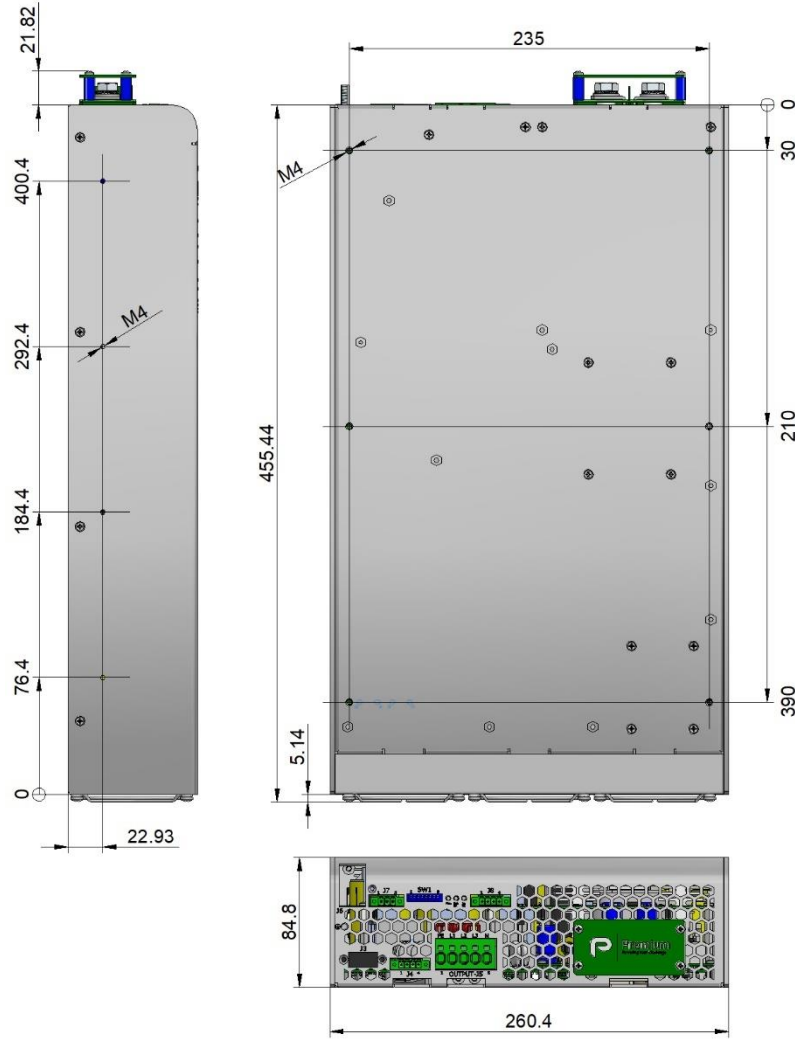

NOTE: All the fixing holes are M4 (torque 2.2 Nm). Maximum screw length inside de inverter 5 mm.
Maximum torque for the M5 earth nut 2.8 Nm

ACCESSORIES

Description	Notes	CODE
Mounting brackets kit	Contains two brackets and screws	NP-9282

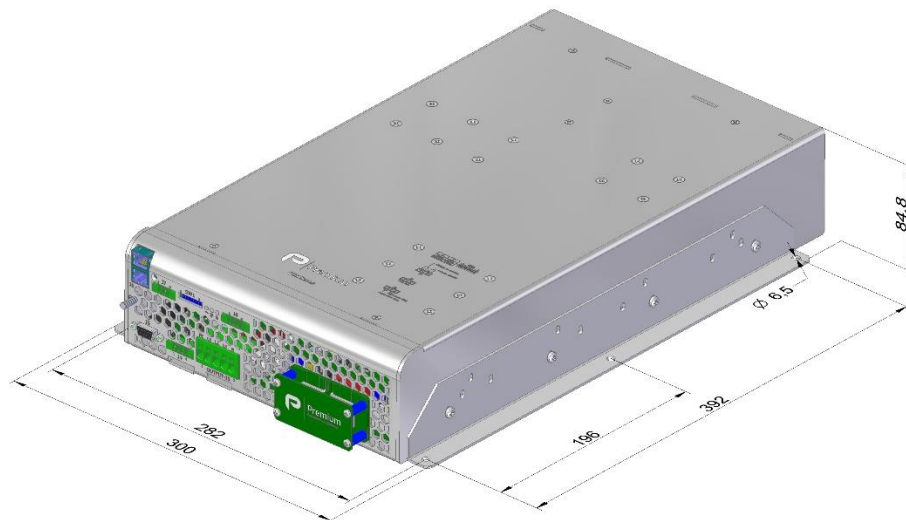



CE EU DECLARATION OF CONFORMITY

The undersigned, representing the following:

Manufacturer: PREMIUM, S. A.,
Address: C/ Dolors Aleu 19-21, 08908 L'Hospitalet de Llobregat, SPAIN

herewith declares that the product:

Type: DC/AC converter
Models: **ODX-6000-7502 ... 7507**

Complies with the essential protection requirements of the following EU directives:

2014/35/EU SI 2016 No 1101	Low voltage / The electrical equipment (safety) regulations
2014/30/EU SI 2016 No 1091	EMC / Electromagnetic compatibility regulations
2011/65/EU Annex II and its amendment 2015/863/EU SI 2012 No. 3032	RoHS / Restriction of the use of certain hazardous substances in electrical and electronic equipment

This declaration applies to all specimens manufactured identical to the samples submitted for testing/evaluation.

Assessment of compliance of the product with the requirements relating to aforementioned directives, was performed by Premium S.A. and is based on the following standards:

EN IEC 62368-1:2020	Safety. Audio/video information and communication technology equipment
EN IEC 61000-6-4:2019	Generic emission standard
EN IEC 61000-6-2:2019	Generic immunity standard
EN 50155:2021*	Railway applications. Electronic equipment used on rolling stock material
EN 50121-3-2:2016*	Railway applications. EMC Rolling stock equipment

* Optional, See annexe

CE marking year: **2019**

Notes:

For the fulfilment of this declaration the product must be used only for the aim that has been conceived, considering the limitations established in the instructions manual or datasheet.

L'Hospitalet de Llobregat, 24-04-2023

Albert Sole
Technical Director

PREMIUM S.A. is an ISO9001 and ISO14001
certified company by **Bureau Veritas**



UK CA UKCA DECLARATION OF CONFORMITY

The undersigned, representing the following:

Manufacturer: PREMIUM, S. A.,
Address: C/ Dolors Aleu 19-21, 08908 L'Hospitalet de Llobregat, SPAIN

herewith declares that the product:

Type: DC/AC converter
Models: **ODX-6000-7502 ... 7507**

Complies with the essential protection requirements of the following regulations:

SI 2016 No 1101	Low voltage / The electrical equipment (safety) regulations
SI 2016 No 1091	EMC / Electromagnetic compatibility regulations
SI 2012 No. 3032	RoHS / Restriction of the use of certain hazardous substances in electrical and electronic equipment

This declaration applies to all specimens manufactured identical to the samples submitted for testing/evaluation.

Assessment of compliance of the product with the requirements relating to aforementioned regulations, was performed by Premium S.A. and is based on the following standards:

BS EN 62368-1:2020	Safety. Audio/video, information and communication technology equipment
BS EN 61000-6-4:2019	Generic emission standard:
BS EN 61000-6-2:2019	Generic immunity standard
BS EN 50155:2021*	Railway applications. Electronic equipment used on rolling stock material
BS EN 50121-3-2:2016*	Railway applications. EMC Rolling stock equipment

* Optional, See annexe

UKCA marking year: **2021**

Notes:

For the fulfilment of this declaration the product must be used only for the aim that has been conceived, considering the limitations established in the instructions manual or datasheet.

L'Hospitalet de Llobregat, 24-04-2023

Albert Sole
Technical Director

PREMIUM S.A. is an ISO9001 and ISO14001
certified company by **Bureau Veritas**

ANNEXE

Applicable values for the different sections of the norm EN50155:2021																																																																		
4.3.1	Working altitude	Up to 2000 m																																																																
4.3.2	Ambient temperature	Class OT2 (-40 to 55 °C): load < 100 % Class OT4 (-40 to 70 °C): load <62.5 %																																																																
4.3.3	Switch-on extended operating temp.	ST1																																																																
4.3.4	Rapid temperature variations	H1																																																																
4.3.5	Shocks and vibrations	According EN61373:2010 Category 1 class B																																																																
4.3.6	EMC Electromagnetic Compatibility EN50121-3-2:2016	<table border="1"> <thead> <tr> <th>Test</th> <th>Norm</th> <th>Port</th> <th>Frequency</th> <th>Limits</th> </tr> </thead> <tbody> <tr> <td rowspan="3">Radiated emissions</td> <td rowspan="3">IEC55016</td> <td rowspan="3">Case</td> <td>30MHz...230MHz</td> <td>40 dB(µV/m) Qpk at 10m</td> </tr> <tr> <td>230MHz...1GHz</td> <td>47 dB(µV/m) Qpk at 10m</td> </tr> <tr> <td>1...3GHz 3...6GHz</td> <td>Do not apply Internal freq. < 108MHz</td> </tr> <tr> <td rowspan="2">Conducted emissions</td> <td rowspan="2">IEC55016</td> <td rowspan="2">Input</td> <td>150kHz...500kHz</td> <td>99 dB(µV) Qpk</td> </tr> <tr> <td>500kHz...30MHz</td> <td>93 dB(µV) Qpk</td> </tr> </tbody> </table>	Test	Norm	Port	Frequency	Limits	Radiated emissions	IEC55016	Case	30MHz...230MHz	40 dB(µV/m) Qpk at 10m	230MHz...1GHz	47 dB(µV/m) Qpk at 10m	1...3GHz 3...6GHz	Do not apply Internal freq. < 108MHz	Conducted emissions	IEC55016	Input	150kHz...500kHz	99 dB(µV) Qpk	500kHz...30MHz	93 dB(µV) Qpk																																											
		Test	Norm	Port	Frequency	Limits																																																												
		Radiated emissions	IEC55016	Case	30MHz...230MHz	40 dB(µV/m) Qpk at 10m																																																												
					230MHz...1GHz	47 dB(µV/m) Qpk at 10m																																																												
					1...3GHz 3...6GHz	Do not apply Internal freq. < 108MHz																																																												
		Conducted emissions	IEC55016	Input	150kHz...500kHz	99 dB(µV) Qpk																																																												
					500kHz...30MHz	93 dB(µV) Qpk																																																												
		<table border="1"> <thead> <tr> <th>Test</th> <th>Norm</th> <th>Port</th> <th>Severity</th> <th>Conditions</th> <th>P</th> </tr> </thead> <tbody> <tr> <td rowspan="2">Electrostatic discharge</td> <td rowspan="2">IEC61000-4-2</td> <td rowspan="2">Case</td> <td>±8 kV</td> <td>Air (isolated parts)</td> <td rowspan="2">B</td> </tr> <tr> <td>±8 kV</td> <td>Contact (conductive parts)</td> </tr> <tr> <td rowspan="4">Radiated high-frequency</td> <td rowspan="4">IEC61000-4-3</td> <td rowspan="4">X/Y/Z Axis</td> <td>20 V/m</td> <td>0.08...1.0 GHz M. 80% 1 kHz</td> <td rowspan="4">A</td> </tr> <tr> <td>10 V/m</td> <td>1.4...2.1 GHz M. 80% 1 kHz</td> </tr> <tr> <td>5 V/m</td> <td>2.1...2.5 GHz M. 80% 1 kHz</td> </tr> <tr> <td>3 V/m</td> <td>5.1...6 GHz M. 80% 1 kHz</td> </tr> <tr> <td rowspan="4">Fast transients</td> <td rowspan="4">IEC61000-4-4</td> <td>Input</td> <td>±2 kV</td> <td rowspan="4">Tr/Th: 5/50 ns</td> <td rowspan="4">A</td> </tr> <tr> <td>Output</td> <td>±2 kV</td> </tr> <tr> <td>Signal</td> <td>±2 kV</td> </tr> <tr> <td>PE</td> <td>±1 kV</td> </tr> <tr> <td rowspan="2">Surge</td> <td rowspan="2">IEC61000-4-5</td> <td>Input L to L</td> <td>±1 kV</td> <td rowspan="2">Tr/Th: 1.2/50 µs</td> <td rowspan="2">B</td> </tr> <tr> <td>Input L to PE</td> <td>±2 kV</td> </tr> <tr> <td rowspan="4">Conducted RF</td> <td rowspan="4">IEC61000-4-6</td> <td>Input</td> <td>10 V</td> <td rowspan="4">0.15...80 MHz M. 80% 1 kHz</td> <td rowspan="4">A</td> </tr> <tr> <td>Output</td> <td>10 V</td> </tr> <tr> <td>Signal</td> <td>10 V</td> </tr> <tr> <td>PE</td> <td>10 V</td> </tr> <tr> <td>Magnetic field</td> <td>IEC61000-4-8</td> <td>X/Y/Z Axis</td> <td>300 A/m</td> <td>0 Hz, 16.7 Hz, 50/60 Hz</td> <td>A</td> </tr> </tbody> </table>	Test	Norm	Port	Severity	Conditions	P	Electrostatic discharge	IEC61000-4-2	Case	±8 kV	Air (isolated parts)	B	±8 kV	Contact (conductive parts)	Radiated high-frequency	IEC61000-4-3	X/Y/Z Axis	20 V/m	0.08...1.0 GHz M. 80% 1 kHz	A	10 V/m	1.4...2.1 GHz M. 80% 1 kHz	5 V/m	2.1...2.5 GHz M. 80% 1 kHz	3 V/m	5.1...6 GHz M. 80% 1 kHz	Fast transients	IEC61000-4-4	Input	±2 kV	Tr/Th: 5/50 ns	A	Output	±2 kV	Signal	±2 kV	PE	±1 kV	Surge	IEC61000-4-5	Input L to L	±1 kV	Tr/Th: 1.2/50 µs	B	Input L to PE	±2 kV	Conducted RF	IEC61000-4-6	Input	10 V	0.15...80 MHz M. 80% 1 kHz	A	Output	10 V	Signal	10 V	PE	10 V	Magnetic field	IEC61000-4-8	X/Y/Z Axis	300 A/m	0 Hz, 16.7 Hz, 50/60 Hz	A
		Test	Norm	Port	Severity	Conditions	P																																																											
		Electrostatic discharge	IEC61000-4-2	Case	±8 kV	Air (isolated parts)	B																																																											
					±8 kV	Contact (conductive parts)																																																												
		Radiated high-frequency	IEC61000-4-3	X/Y/Z Axis	20 V/m	0.08...1.0 GHz M. 80% 1 kHz	A																																																											
					10 V/m	1.4...2.1 GHz M. 80% 1 kHz																																																												
					5 V/m	2.1...2.5 GHz M. 80% 1 kHz																																																												
					3 V/m	5.1...6 GHz M. 80% 1 kHz																																																												
Fast transients	IEC61000-4-4	Input	±2 kV	Tr/Th: 5/50 ns	A																																																													
		Output	±2 kV																																																															
		Signal	±2 kV																																																															
		PE	±1 kV																																																															
Surge	IEC61000-4-5	Input L to L	±1 kV	Tr/Th: 1.2/50 µs	B																																																													
		Input L to PE	±2 kV																																																															
Conducted RF	IEC61000-4-6	Input	10 V	0.15...80 MHz M. 80% 1 kHz	A																																																													
		Output	10 V																																																															
		Signal	10 V																																																															
		PE	10 V																																																															
Magnetic field	IEC61000-4-8	X/Y/Z Axis	300 A/m	0 Hz, 16.7 Hz, 50/60 Hz	A																																																													
P= Performance criteria, L= Line, PE= Protective Earth																																																																		
4.3.7	Relative humidity	Up to 95%																																																																
5.1.1.2	DC power supply range	From 0.70 to 1.25 Un continuous																																																																
5.1.1.3	Temporary DC power supply fluctuation	From 0.60 to 1.40 Un 0.1 s From 1.25 to 1.40 Un 1 s without damage																																																																
5.1.1.4	Interruptions of voltage supply	Class S1 (without interruptions)																																																																
5.1.1.6	Input ripple factor	10% peak to peak with a DC Ripple Factor of 5 %																																																																
5.1.3	Supply change-over	0.6 Un duration 100ms (without interruptions). Performance criterion A																																																																
7.2.7	Input reverse polarity protection	By external fuse																																																																
10.7	Protective coating for PCB assemblies	Class PC2																																																																
13.3	Tests list	<table border="0"> <tr><td>1 Visual Inspection</td><td>Routine</td></tr> <tr><td>2 Performance test</td><td>Routine</td></tr> <tr><td>3 Power supply test</td><td>Routine</td></tr> <tr><td>4 Insulation test</td><td>Routine</td></tr> <tr><td>5 Low temperature storage test</td><td>-</td></tr> <tr><td>6 Low temperature start-up test</td><td>Type</td></tr> <tr><td>7 Dry heat test</td><td>Type</td></tr> <tr><td>8 Cyclic damp heat test</td><td>Type</td></tr> <tr><td>9 Salt mist test</td><td>-</td></tr> <tr><td>10 Enclosure protection test (IP code)</td><td>-</td></tr> <tr><td>11 EMC test</td><td>Type</td></tr> <tr><td>12 Shocks and vibrations test</td><td>Type</td></tr> <tr><td>13 Equipment stress screening test</td><td>Routine: at 40°C and load 100%</td></tr> <tr><td>14 Rapid Temperature variation test</td><td>Type</td></tr> </table>	1 Visual Inspection	Routine	2 Performance test	Routine	3 Power supply test	Routine	4 Insulation test	Routine	5 Low temperature storage test	-	6 Low temperature start-up test	Type	7 Dry heat test	Type	8 Cyclic damp heat test	Type	9 Salt mist test	-	10 Enclosure protection test (IP code)	-	11 EMC test	Type	12 Shocks and vibrations test	Type	13 Equipment stress screening test	Routine: at 40°C and load 100%	14 Rapid Temperature variation test	Type																																				
1 Visual Inspection	Routine																																																																	
2 Performance test	Routine																																																																	
3 Power supply test	Routine																																																																	
4 Insulation test	Routine																																																																	
5 Low temperature storage test	-																																																																	
6 Low temperature start-up test	Type																																																																	
7 Dry heat test	Type																																																																	
8 Cyclic damp heat test	Type																																																																	
9 Salt mist test	-																																																																	
10 Enclosure protection test (IP code)	-																																																																	
11 EMC test	Type																																																																	
12 Shocks and vibrations test	Type																																																																	
13 Equipment stress screening test	Routine: at 40°C and load 100%																																																																	
14 Rapid Temperature variation test	Type																																																																	