

HBC400 Series

E-Mobility 4kW DC/DC Isolated Bi-directional Power Converter Module



Product Overview

HBC400 is a series of rugged, highly efficient, 4kW liquid-cooled, bidirectional DC/DC power converters that convert 220-440V high side DC input voltage into a 12Vdc or 24Vdc isolated low side voltage, supporting 12/24V battery configurations.

HBC400 power converters incorporate a digitally controlled Dual Active Bridge topology with synchronous output rectification to achieve high efficiency and EMI performance. The compact thermally optimized IP67 ingress rated enclosure provides a high degree of shock and vibration resistance, suitable for deployment within harsh environments.

Bidirectional conversion capability:

- **Buck-Mode Direction:** Converts the high side input voltage (220- 440Vdc) into a 12V/24V low-side output.
- **Boost-Mode Direction:** Converts low side input of 12V/24V into the high-side output voltage (220-440Vdc).

The comprehensive SAE J1939 compliant CAN digital interface, standard hardware signals including HVIL (High Voltage Interlock Loop) and the bi-directional conversion features make this series suitable for adaptation in industrial, agriculture, marine, mining and other E-mobility applications.

Features

- 4kW output power
- Bi-directional operation
- Wide high-side Input Voltage range: 220V to 440Vdc via robust Amphenol Powerlok series connector with integrated HVIL contacts
- 12Vdc and 24Vdc models, supporting 12/24V battery configurations
- CAN 2.0B SAE J1939 compliant digital communications interface for monitoring, control and configuration capability
- High efficiency; up to 96%
- Input to output safety isolation
- Liquid cooled, IP67 rugged enclosure: 359 (L) x 205 (W) x 78 (H) suitable in harsh environments
- Over-Current, Short-Circuit and Over-Temperature fault protection
- E-Mark pending

Contents

Ordering Guide.....	2
Typical Application Diagram	2
Electrical Specifications.....	3
Connector Details.....	6
Signal Interface Details	8
Typical Performance Characteristics.....	9
Mechanical Specifications	13

ORDERING GUIDE

Model	High-Side Voltage	Low-Side Voltage (Nominal)	Output Voltage	Low-Side Current	Configuration	Max. Output Power
400S12.4K0HBC	220-440VDC	14Vdc	8-16VDC	300A	Liquid Cooled	4kW
400S24.4K0HBC		28Vdc	16-32VDC	150A		

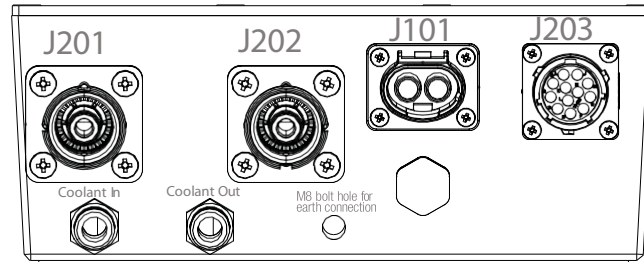

Connections

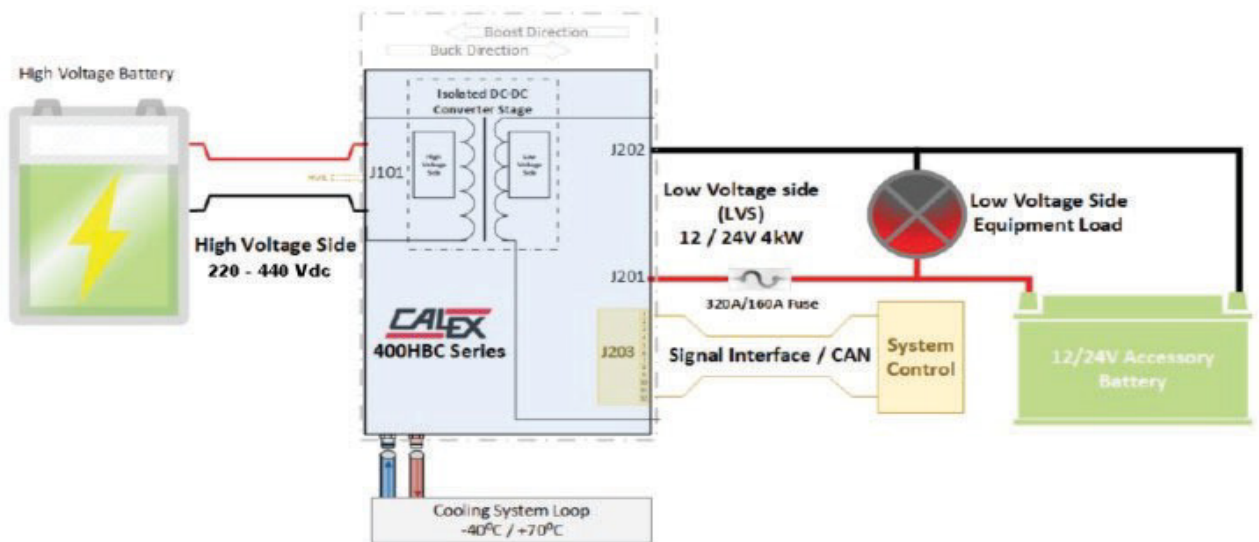

Typical Application Diagram

HBC400 series power converter modules incorporate an isolated Dual Active Bridge conversion stage to achieve efficient performance and bi-directional operation. This converter provides safety isolation between the high voltage input side and the low voltage side, including the 12Vdc or 24Vdc output side and CAN digital communication bus and hardware signals of J203 E-Mobility application specific hardware signals:

- **J101:** HV side connection; Amphenol Powerlok series PL082X-61-6 with HVIL.
- **J201:** Low-voltage side positive output connection (isolated from high voltage side), Amphenol Surlock series connector SLP P C 85 BSR0.
- **J202:** Low-voltage side negative output connection (isolated from high voltage side); Amphenol Surlock series SLP P C 85 BSB1.
- **J203:** Signal interface (isolated from high voltage side); 12-way TE connectivity / DEUTSCH DT Series Housing: DTM04-12PB-L012 Contacts QTY 12: 0460-202-20141 provides access to hardware and digital communications/CAN bus.

Coolant In/Out Couplers: Legris (outer diameter 12mm)



ELECTRICAL SPECIFICATIONS

General conditions for power converter module under test unless otherwise specified: Typical at TA = +25°C under nominal line voltage and nominal load conditions. The following specifications are organized by direction mode of power conversion:

- **Buck Mode:** Input voltage applied to the high voltage side connector is converted to a low voltage side 12Vdc or 24Vdc (see Ordering Guide) output voltage.
- **Boost Mode:** The DC voltage applied to the low side input is converted to a 220-440Vdc high-side voltage.

Parameter	Conditions	Min.	Typ.	Max.	Units
GENERAL OUTPUT CHARACTERISTICS					
Output Power	See Derating Curves			4000	W
Turn-On Overshoot	Vout TYP	5		10	%
Parallel Operation	Maximum 4 units			16	kW

BUCK MODE

INPUT CHARACTERISTICS

Parameter	Conditions	Min.	Typ.	Max.	Units
Input Voltage Range ¹	Operating Input Voltage Range	220	350	440	Vdc
Turn-on Voltage	Default, ramping up	210	215	220	Vdc
Turn-off voltage	Default, ramping down	200	205	210	Vdc
Input Current	350Vdc input, 4kW output			13	Adc
Input Fuse	Must be provided externally by end user				
Input Over-Voltage Protection	Latching; requires a power cycle to reset	450		465	Vdc
Efficiency	Vin = 350Vdc, Vo = 14.5V, 150A; 29V, 75A load current	96			%

12V OUTPUT CHARACTERISTICS (400S12.4KOHBC MODEL)

Initial Voltage Set-point	Set at factory		14		Vdc
Output Voltage Trim Range	Adjustment range for output voltage	9		16	Vdc
Output Current [1]				300	Adc
Output Over-Current Protection	Brick wall/Constant Current	300		310	Adc
Over-Voltage Protection	Latching; requires power cycle to reset	17		18	Vdc

24V OUTPUT CHARACTERISTICS (400S24.4KOPHBC MODEL)

Initial Voltage Set-point	Set at factory		28		Vdc
Output Voltage Trim Range	Adjustment range for output voltage	22		30	Vdc
Output Current [1]				150	Adc
Output Over-Current Protection	Brick wall/Constant Current	150		160	Adc
Over-Voltage Protection	Latching; requires power cycle to reset	32		34	Vdc

¹ See the derating curves for additional details.

BOOST MODE

Parameter	Conditions	Min.	Typ.	Max.	Units
12V INPUT CHARACTERISTICS					
Input Voltage Range	Operating Input Voltage Range	9	14	16	Vdc
Turn-on Voltage	Default, ramping up	8		9	Vdc
Turn-off voltage	Default, ramping down	8		9	Vdc
Efficiency	Vin = 14.0V; Vout = 350V; 50% load	96			%

24V INPUT CHARACTERISTICS

Parameter	Conditions	Min.	Typ.	Max.	Units
Input Voltage Range	Operating Input Voltage Range	22	28	30	Vdc
Turn-on Voltage	Default, ramping up	17		18	Vdc
Turn-off voltage	Default, ramping down	16		18	Vdc
Efficiency	Vin = 28.0V; Vout = 350V; 50% load	96			%

OUTPUT CHARACTERISTICS (Constant Current Characteristics)

Parameter	Conditions	Min.	Typ.	Max.	Units
Voltage Range		220	350	440	Vdc
Output Current Range	Adjustment range for output current ¹	0		13	Adc

¹ See the derating curves for additional details.

Note: External fuse, 320A/160A is required between the external low voltage battery and the HBC400 module.

ENVIRONMENTAL CHARACTERISTICS

Parameter	Conditions	Min.	Typ.	Max.	Units
Altitude	IEC 60068-2-13-1999			3600	m
Operating Temperature	SAEJ1455 test method	-40		+85	°C
Storage Temperature	IEC 60068-2-1-2007	-40		+95	°C
Coolant Characteristics	50%/50% Water/Glycol mix; @ 6l/min; Pressure drop: < 100mbar				
Coolant Temperature Range		-40		+65	°C
Coolant Flow		0.02			l/sec
Coolant Pressure				20	PSI
Max Coolant Pressure Drop				1	PSI
Over Temperature Shutdown	Self-Recovers		+95		°C
Ingress Protection	IP67, ISO20653-2013				
Humidity	SAE J1455				
Vibration	IEC 60068-2-64-2008				
Shock	IEC 60068-2-27-2009				
Salt Mist	IEC 60068-2-11-1999				
RoHS Compliance	See the Calex website at http://www.calex.com/RoHS.html for the complete RoHS compliance statement.				

SAFETY, REGULATORY, EMC SPECIFICATIONS

Parameter	Conditions	Criterion
Insulation	Input to Output - 4242Vdc Input to Chassis - 121Vdc	
ESD	ISO13766-2-2018	Criteria B
Radiated Emissions	ECE R10	
Conducted Emissions	CISPR25	Class 1
BCI	ISO11452-1 1MHz-400MHz, 100~A	
Radiated Immunity	ISO11452-1 400-1000MHz, 100v/m 1000-2000MHz, 30v/m 2000-2700MHz, 10v/m	
Conducted Transient Immunity	ISO7637-2, ISO6750-2	Pulse's 1, 2a, 2b, 3a, 3b, 4, 5

CONNECTOR DETAILS

INPUT CONNECTOR, HIGH VOLTAGE SIDE J101

MODULE SIDE Receptacle: Amphenol Powerlok Series, PL082X-61-6

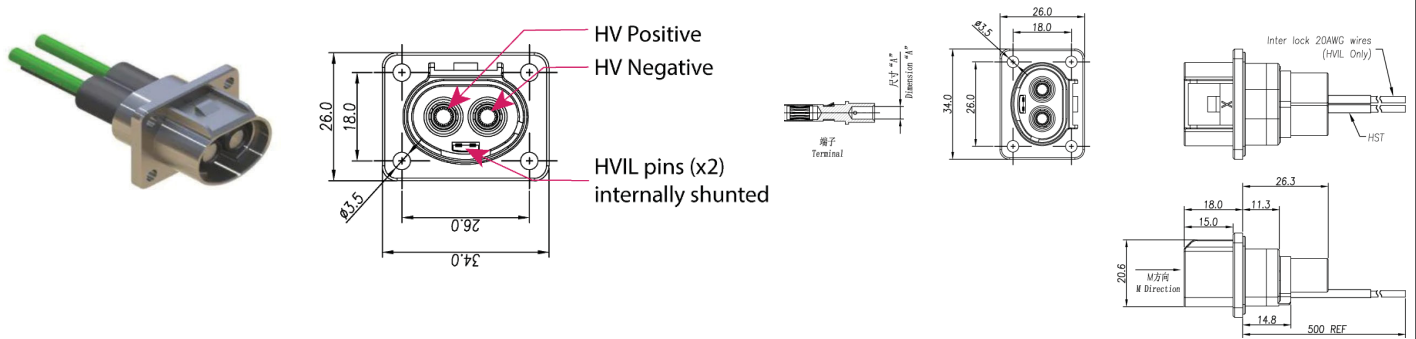

SYSTEM SIDE (MATING HALF) Plug: Amphenol Powerlok Series, PL182X-61-6

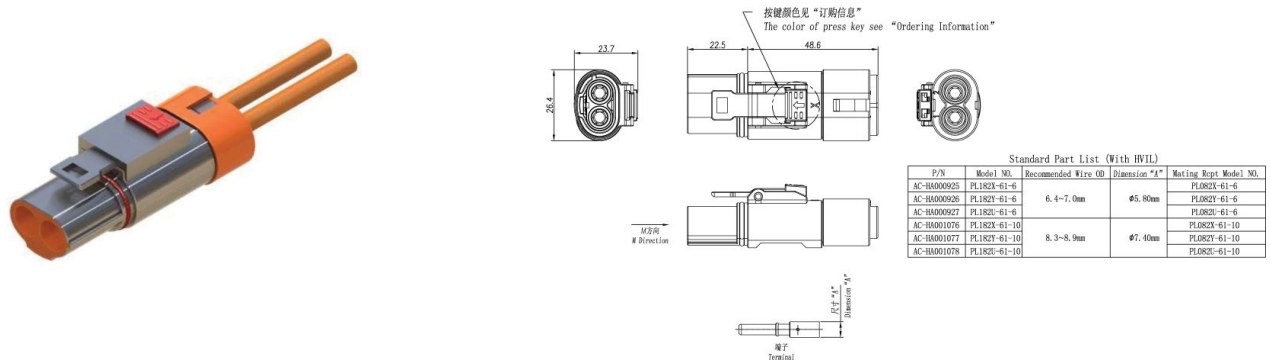

OUTPUT CONNECTOR LOW VOLTAGE SID (LVS)¹ J201, J202

Low Voltage Side Output connections are based on Amphenol Surlok Series receptacle/plug as follows:

Module Side (Receptacle):

Low Voltage side Positive (J201) = SLP IR C BPSR0
 Low Voltage side Negative (J202) = SLP IR CTPSB1



System Side (plug):

Low Voltage side Positive = SLP P C 85 BSR0
 Low Voltage side Negative = SLP P C 85 BSB1

Right Angle Plug

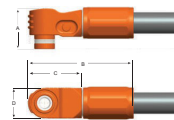

Size	Plug Dimension			
	A	B	C	D
10.3mm	41.2	84.5	42.5	28.0

¹ Shown for illustration purposes only. See the MFR specifications for additional details.

SIGNAL/CAN CONNECTOR J203

Signal Connector Interface based on AMPHENOL 12-way receptacle/plug as follows:

POWER CONVERTER SIDE RECEPTACLE; COMPRISED OF THREE COMPONENTS:

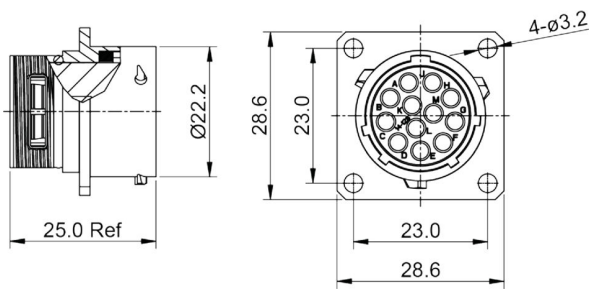
Description	MPN	Illustration
RECEPTACLE ecolmate® rm Series	AMPHENOL RT001412SNH	<p>Square Flange Receptacle</p>  <p>Female RT001412</p> <p>Square Flange Receptacle with O-ring Seal and End Cap with Individual Rear Wire Seal</p>

SYSTEM SIDE (MATING HALF) PLUG [1]:

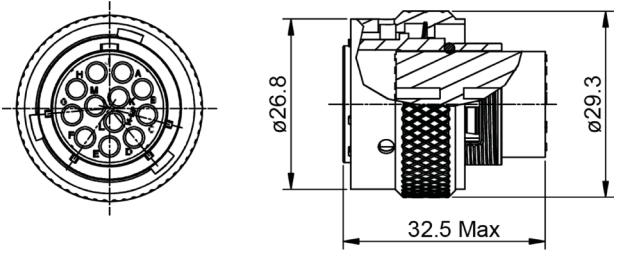
Description	MPN	Illustration
PLUG ecolmate® rm Series	AMPHENOL RT061412PNH-K (Complete plug kit, including connector, back-shell and contacts, refer to Amphenol's datasheet for additional options).	 <p>Male Figure 6 RT061412PNH</p>

* Shown for illustration purposed only; refer to MFR specifications for fine detail

SIGNAL INTERFACE DETAILS

Pin Map and Signal Description J203

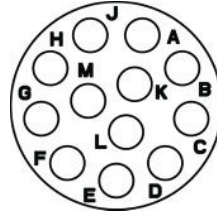

Insert Arrangement
Pin (Male) Faceview

Signal Name	Input/ Output	Pin #	Description	Interface Details
PS_WAKEUP	Input	A	Pull-down to GND to disable the converter; open to enable	Internally pulled up to 12/24Vdc battery voltage via 470k resistor
ADRO	Input	B	Internal ECU Address select. Note: address pins must be set prior powering up the unit	Internally pulled up to 3.3V via 1k resistor ³
ADR1	Input	C		
Not used	Not used	D	Not used	
CAN_H	Bidirectional	E	CAN differential High line I/O – “High” in dominant state	500kbps
CAN_L	Bidirectional	F	CAN differential Low line I/O – “Low” in a dominant state	
Not used	Not used	G	Not used	
Not used	Not used	H	Not used	
Not used	Not used	I	Not used	
+12V	Input	J	Connection of this input signal to the LVS auxiliary battery (or equivalent LVS source is required to provide startup power to the APM’s internal low voltage logic supply.	Input Range: 9-32Vdc
Chassis Ground	Output	K	Reference ground for communications and low voltage logic power supply.	
SENSE+	Input	L	Battery sense connections; connect at point of load to compensate for voltage drop due to load connection losses. Compensates for up to 500mV maximum (total for both +/-connection paths). Can be safely operated without connection (the output will remain within regulation as measured at power converter module’s output connector).	
SENSE -	Input	M		

¹ Address pins must be set prior to power-up.

² For applications using a separate power supply for J203 (other than the low voltage auxiliary battery): ensure the returns of the power supply and LVS auxiliary battery are connected together.

³ Refer to ACAN-136 for additional details.

TIMING CHARACTERISTICS

Parameter	Conditions	Min.	Typ.	Max.	Units
Turn-On Delay	Rise Time			200	ms
	Power On Delay			1	s
	By PS_ON delay			1	s
Turn-Off Delay	ENABLE delay			100	ms
Buck/Boost Direction Change Delay	Direction change Delay			30	ms

TYPICAL PERFORMANCE CHARACTERISTICS

DERATING, OUTPUT POWER VS. INPUT/OUTPUT VOLTAGE

12V Model - Buck Mode

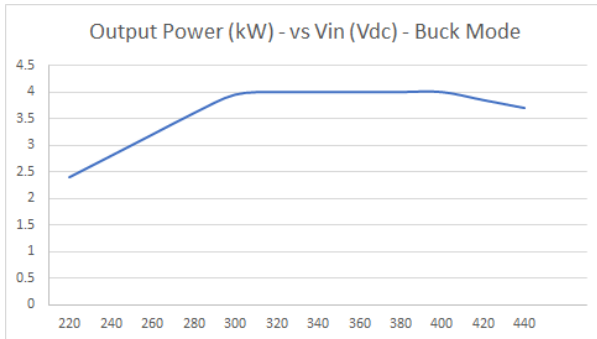

24V Model - Buck Mode

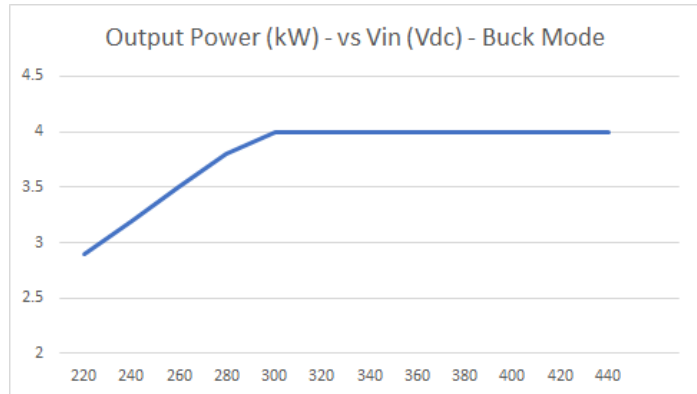

12V Model - Buck Mode

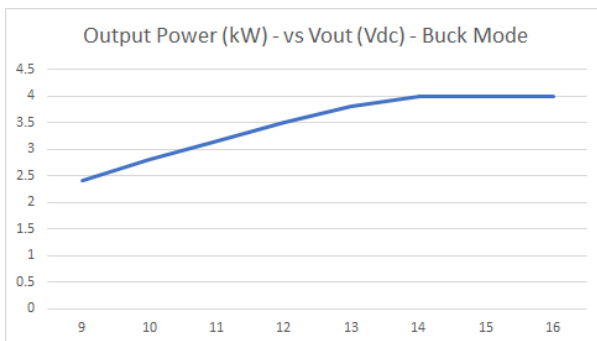

24V Model - Buck Mode

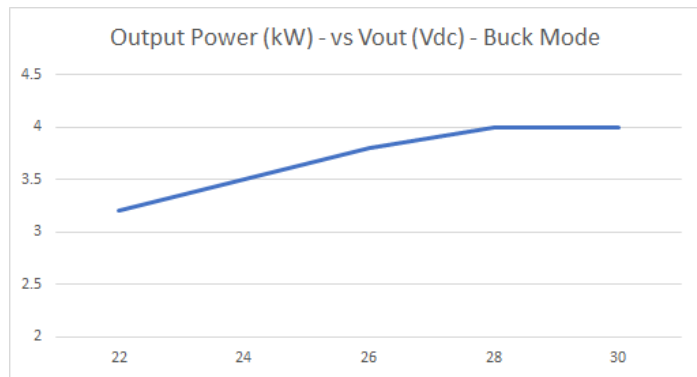

DERATING, OUTPUT POWER VS INPUT/OUTPUT VOLTAGE

12V Model - Boost Mode

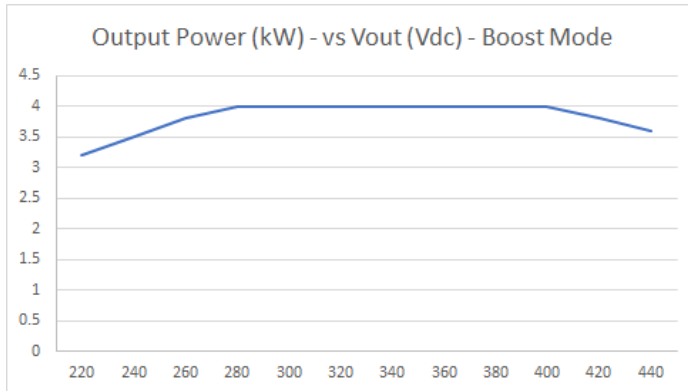

24V Model - Boost Mode

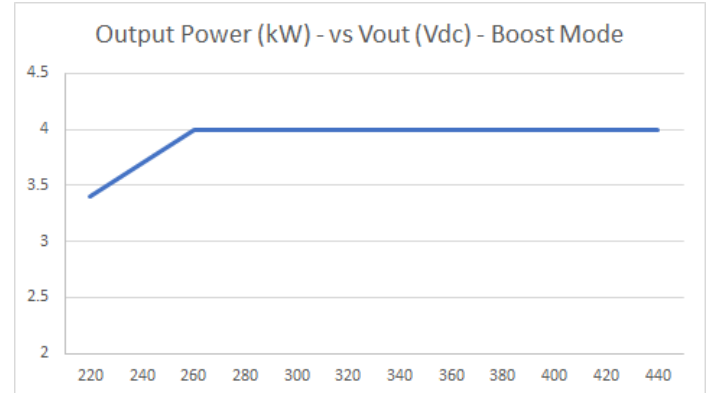

12V Model - Boost Mode

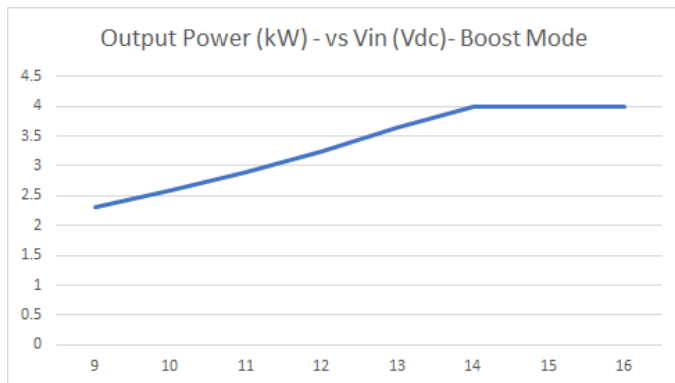

24V Model - Boost Mode

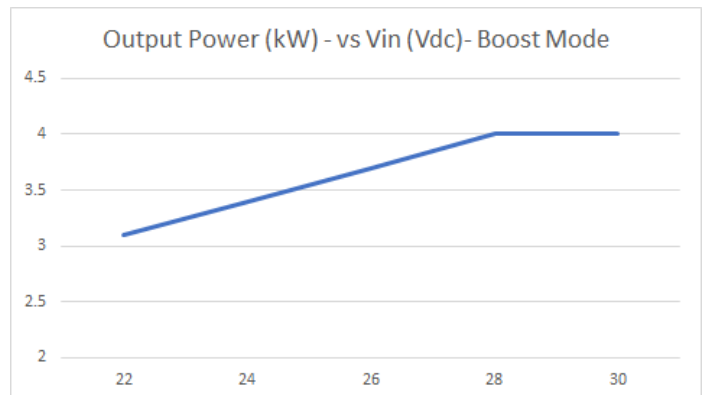

EFFICIENCY

12V Model

Vin: 410Vdc, Vout: 9-16Vdc, 1V increments

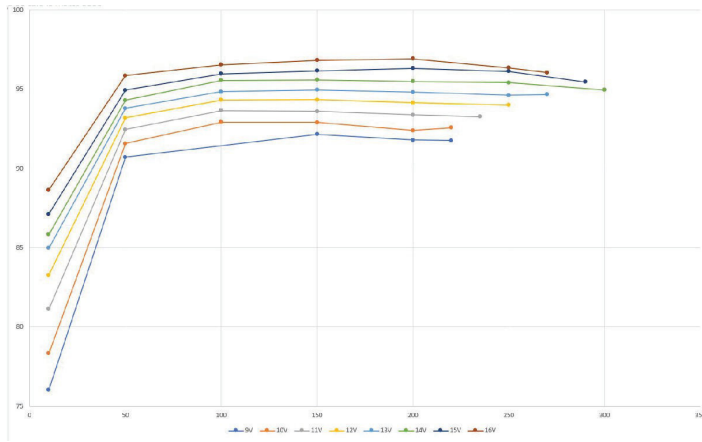

Vin: 350Vdc, Vout: 9-16Vdc, 1V increments

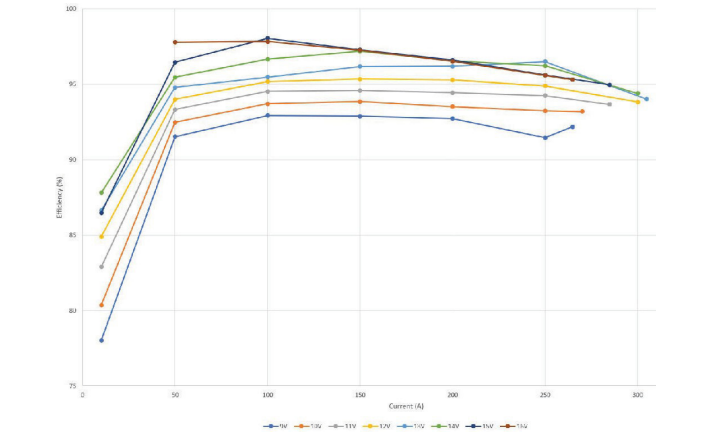

Vin: 220Vdc, Vout: 9-16V, 1V increments

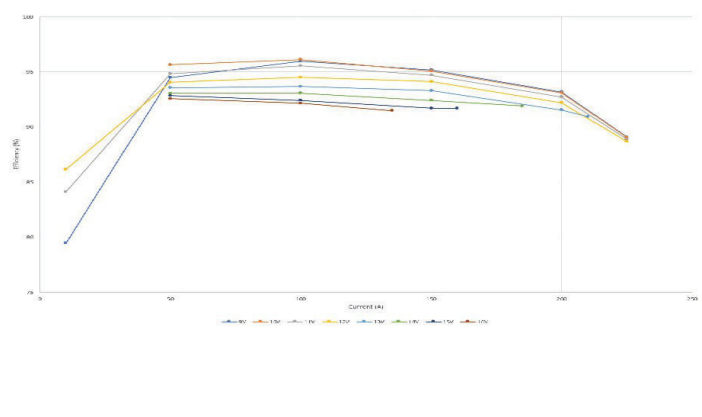

TYPICAL WIRING DIAGRAM

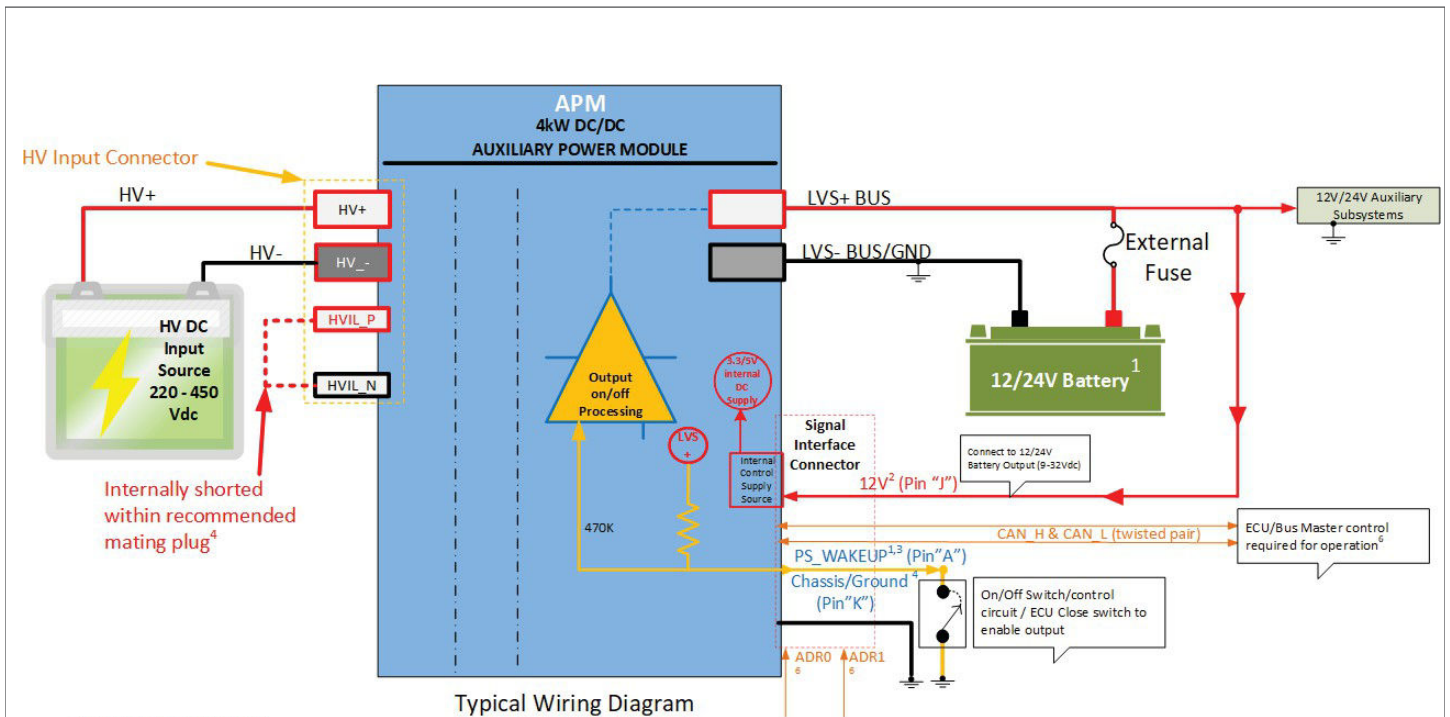

Connection Notes:

- 1) Use appropriate battery / voltage for the APM module Auxiliary battery
Auxiliary battery serves these main purposes:
 - Provides The low voltage power source necessary to operate the low voltage system side and internal APM circuits via Pin "J" 12V signal (input)
 - Provides the voltage for the "PS_WAKEUP" signal, to enable APM operation either directly or via system / ECU processing such as Ignition sensing/processing
- 2) The +12V is an input form the aux. battery +12 or +24V supply that is needed to power internal logic level circuits. If using an external DC bench supply rather than the auxiliary LVS battery then the DC source's Return needs to be connected to the APM ground/LVS -
- 3) PS_WAKEUP is internally pulled up via 470K to the LVS + voltage (12V or 24V depending upon the model). To enable the output, the signal must be tied to ground or 12 / 24V Negative.
- 4) The datasheet recommended input mating/system-side plug features a built in jumper across the HVIL pins therefore no further accommodations are needed for HVIL in that case
- 5) Chassis Ground is the reference point for the low voltage signals and is internally connected to chassis within the APM
- 6) Refer to ACAN-136 (DBC file) for details related to CAN J1939 digital communication and addressing. ADRO and ADR1 can be left floating or tied to ground for valid address settings.

Mechanical Specifications

Mechanical	Description	Unit
Dimensions	359 (L) x 205 (W) x 78 (H)	mm
Weight	6	kg
Enclosure	Aluminum, anodized IP67	

OUTLINE DRAWING

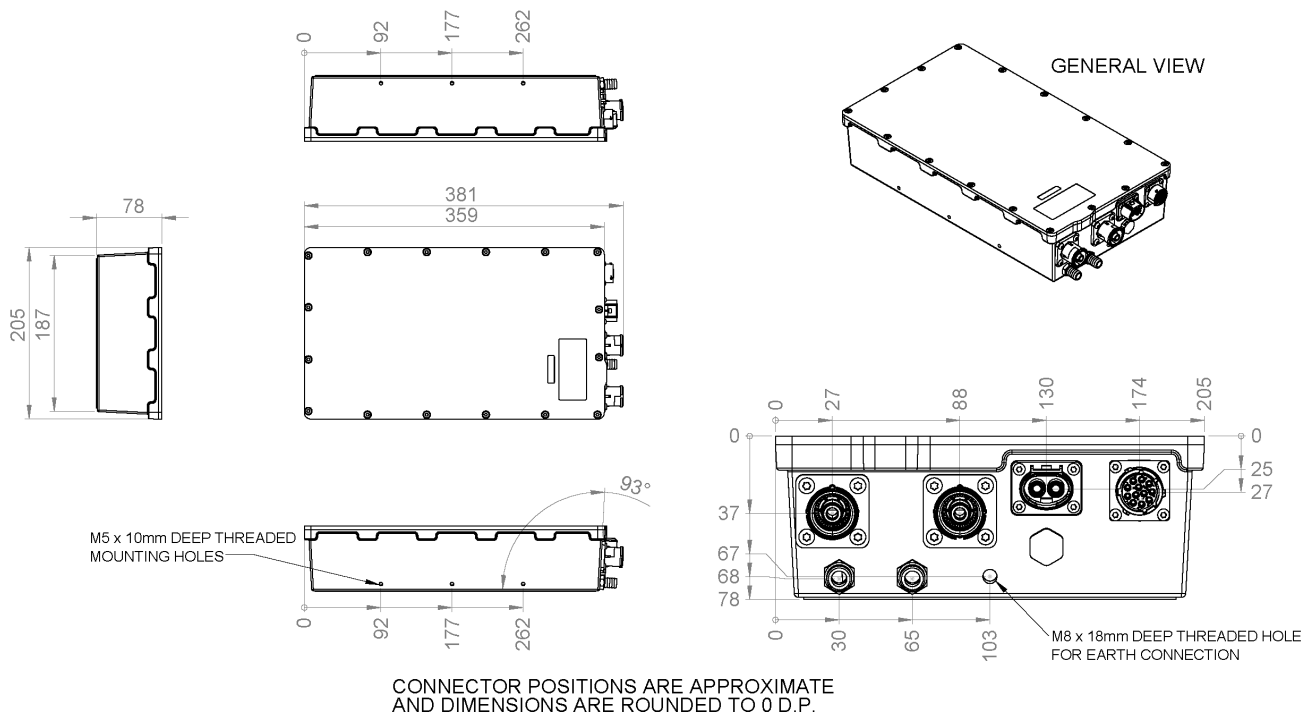

MECHANICAL NOTES:

- THIS DRAWING IS A GRAPHICAL REPRESENTATION OF THE POWER MODULE SHOWN FOR ILLUSTRATION PURPOSES. NOT ALL FINE DETAILS ARE SHOWN. CONTACT CALEX FOR 3D MODEL OR F COMPONENT DRAWINGS FOR DETAILED DIMENSIONS AND MATERIAL INFORMATION.
- REFERENCE FILE: 210614_DRG1143-1A DC DC CONVERTER ASSEMBLY.
- DIMENSIONS: MM, MATERIAL: 0.80MM HOT DIPPED GALVANIZED STEEL, GRADE G60 MINIMUM SPANGLE FINISHED WITH A CR(6+) FREE CORROSION RESISTANT COATING.
- DIMENSIONS OF CONNECTOR LOCATIONS SHOWN TO CENTRE OF CONNECTORS.
- HOSE TAILS FOR COOLING CIRCUIT TO FIT 12MM INNER DIAMETER HOSE FOR BOTH INLET AND OUTLET FLOW.
- CONNECTOR LOCATIONS ARE APPROXIMATE.
- DIMENSIONS ARE ROUNDED TO 0 DP.

Optional Mounting Bracket Kit (Contact Calex for Availability)

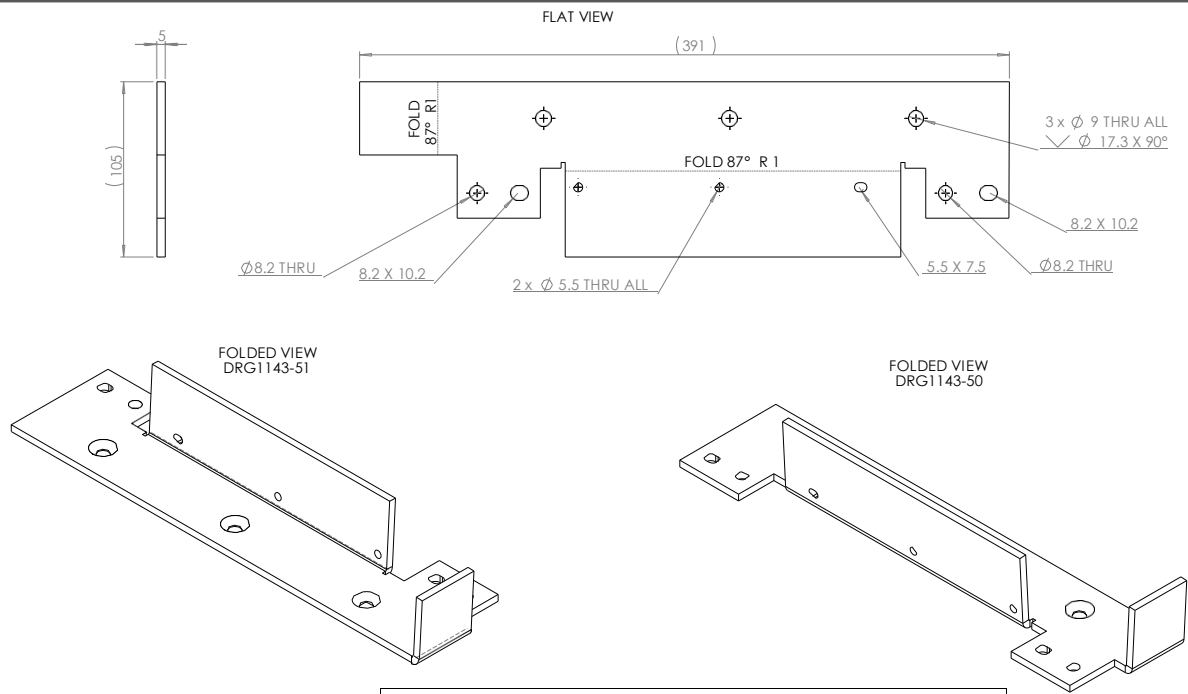

TABLE 1 - PART CONTROL TABLE

PART NUMBER	ISSUE	DESCRIPTION	DIRECTION OF FOLDS	APPROX. WEIGHT (KG)
DRG1143-50	A	MOUNTING BRACKET, RH	DOWNWARDS	0.4
DRG1143-51	A	MOUNTING BRACKET, LH	UPWARDS	0.4

