

SL POWER SLE18 SERIES

18 Watts Single Output
External Power Adapters



Medical



Industrial

LEAN  LINE

Advanced Energy's SL Power SLE18 series of plug-in wall-mount AC-DC power adapters feature both medical and ITE safety approvals. It meets Department of Energy Level VI and European Code of Conduct V5 Tier 2 Directive efficiency standards.

SPECIAL FEATURES

- Medical and ITE safeties
- Interchangeable AC plugs
- 2 x MOPP input to output isolation
- Suitable for medical equipment up to class BF
- Low leakage current less than 100 μ A
- Overvoltage, overcurrent and short circuit protection
- EU CoC V5 Tier 2 compliant
- DoE Efficiency level VI
- \leq 0.075 W standby power
- Up to 5000 m operating altitude

SAFETY

- CB Medical: IEC 60601-1
ANSI/AAMI ES 60601-1
ITE: IEC 62368-1,
UL 62368-1
- UL Medical: CAN/CSA C22.2.
No. 60601-1
ITE: CAN/CSA C22.2
No. 62368-1
- TUV Medical: EN 60601-1
ITE: EN 62368-1
- RCM ITE: AS/NZS 62368-1

AT A GLANCE

Total Power

18 Watts

Input Voltage

90 to 264 VAC

of Outputs

Single



ELECTRICAL SPECIFICATIONS

Input	
Input Voltage Range	90 to 264 VAC
Frequency	47 to 63 Hz
Input Current	0.5 A @ 90 VAC
Inrush Current	70 A @ 240 VAC cold start
Touch Leakage Current	≤ 100 μA @ 264 VAC
Isolation Safety Rating	Input to output: 4,000 VAC (2 x MOPP)
Dielectric Withstand Voltage	Input to output: 5,656 VDC
Insulation Resistance	Input to output: 100 Mohms, 500 VDC
Output	
Output Voltage	5.0 V, 12.0 V, 18.0 V, 24.0 V
Voltage Regulation	±6% for 5.0 V model, ±5% for other models
Start-up Delay	≤ 3 s
Overvoltage Protection	120% to 150% rated output voltage, recycle input to reset
Overload Protection	120% to 150% rated output power, auto-recovery
Short Circuit Protection	Trip and restart, hiccup mode

RELIABILITY

MTBF	> 100,000 hours MIL-HDBK-217 at 25°C
------	--------------------------------------

ENVIRONMENTAL SPECIFICATIONS

Operating Temperature	0 to +45°C ambient
Storage Temperature	-20 to +60°C
Operating Humidity	10% to 90% RH, non-condensing
Storage Humidity	5% to 90% RH
Operating Altitude	5,000 m
Weight	140 g
Dimension	88 x 30 x 57 mm
Packing Quantity	Individual box: 60/carton, egg-crate: 50/carton

EMC/EMI COMPLIANCE

Conducted Emissions	Medical: IEC/EN 60601-1-2, CISPR 11 ITE: EN 55022, CISPR 22
Radiated Emissions	Medical: IEC/EN 60601-1-2, CISPR 11 ITE: EN 55022, CISPR 22
Immunity	Medical: IEC/EN 60601-1-2 ITE: EN 55024, CISPR 24
Electro-Static Discharge (ESD) Immunity on Power Ports	EN 61000-4-2, ±15 kV air, ±8 kV contact
Radiated RF EM Fields Susceptibility	EN 61000-4-3, 10 V/m, 3 V/m (80 MHz to 2700 MHz)
Electrical Fast Transients (EFT) / Bursts	EN 61000-4-4, ±2 kV on AC port, ±1 kV on signal ports
Surges, Line to Line (DM) and Line to Ground (CM)	EN 61000-4-5, ±1 kV line to line (diff mode)
Conducted RF Immunity	EN 61000-4-6, 3 Vrms, 6 Vrms (0.15 MHz to 80 MHz)
Power Frequency Magnetic Field Immunity	EN 61000-4-8, 30 A/m
Voltage Dip Immunity	EN 61000-4-11, 0%, 70%, 0% of UT
Harmonic Current Emissions	EN 61000-3-2, Class A
Flicker Test	EN 61000-3-3

ORDERING INFORMATION - SLE18 SERIES

Model Number ^{3,4,5}	Maximum Power	Output Voltage ¹	Maximum Load	Ripple & Noise ²	Line Regulation	Load Regulation	Efficiency (Average)
SLE18S0503B01	15.0 W	5.0 V	3.0 A	200 mV pk-pk	± 1%	± 5%	81.84%
SLE18S1203B01	18.0 W	12.0 V	1.5 A	200 mV pk-pk	± 1%	± 5%	85.05%
SLE18S1803B01	18.0 W	18.0 V	1.0 A	200 mV pk-pk	± 1%	± 5%	85.19%
SLE18S2403B01	18.0 W	24.0 V	0.7 A	200 mV pk-pk	± 1%	± 5%	85.26%
SLE18S0599B01	15.0 W	5.0 V	3.0 A	200 mV pk-pk	± 1%	± 5%	81.84%

Note:

- Other output voltages in the range of 5 V through 24 V are available, contact our sales representative for details.
- Measured at output connector with 20 MHz bandwidth and 0.1 µF ceramic in parallel with 10 µF electrolytic capacitors.
- "B" in the model number (SLE18S0503B01) indicates interchangeable blade model.
- "03" in the model number indicates 2.5 x 5.5 x 9.5 mm straight barrel type connector. "99" indicates USB "A" port output.
Other output connector options are available, please contact our sales representative for details.
- Power supply is not fitted with the AC blade, this is to be ordered separately. See outline drawing below for details
- Power supplies are not medical equipment (applied parts), medical product manufacturers take responsibility for further evaluation of class B/BF/CF compliance of their end product.

MECHANICAL DRAWINGS

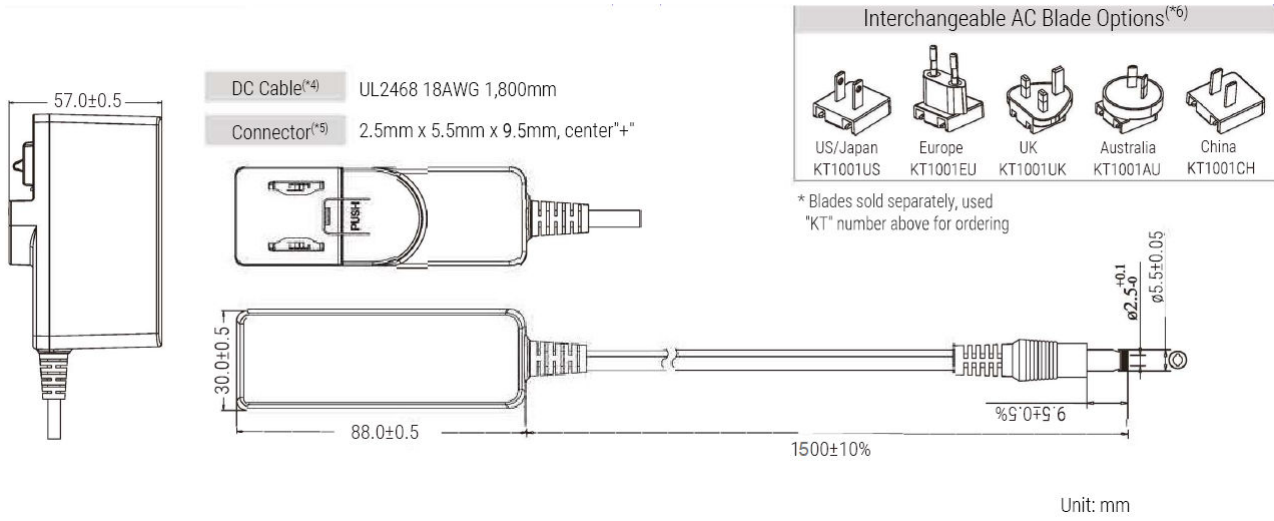



For international contact information,
visit advancedenergy.com.

powersales@aei.com (Sales Support)
productsupport.ep@aei.com (Technical Support)
+1 888 412 7832

ABOUT ADVANCED ENERGY

Advanced Energy (AE) has devoted more than three decades to perfecting power for its global customers. AE designs and manufactures highly engineered, precision power conversion, measurement and control solutions for mission-critical applications and processes.

Our products enable customer innovation in complex applications for a wide range of industries including semiconductor equipment, industrial, manufacturing, telecommunications, data center computing, and medical. With deep applications know-how and responsive service and support across the globe, we build collaborative partnerships to meet rapid technological developments, propel growth for our customers, and innovate the future of power.

PRECISION | POWER | PERFORMANCE | TRUST

Specifications are subject to change without notice. Not responsible for errors or omissions. ©2023 Advanced Energy Industries, Inc. All rights reserved. Advanced Energy®, AE® and Artesyn™ are U.S. trademarks of Advanced Energy Industries, Inc.