

# ARTESYN MODULAR HIGH POWER SYSTEM

Up to 20000 Watts



Designed for a wide range of industrial, lighting/horticulture and semiconductor applications, Advanced Energy's iHP Liquid Cooled configurable precision power system provides accuracy, resolution and stability as either a programmable voltage or current source. It provides up to 20 kW.

The iHP power system has industrial safety approvals, including compliance to the SEMI F47 standard for semiconductor processing equipment when operated at 480VAC input. The Liquid version of the iHP short rack is factory configured as a single output standard. Contact factory if multiple outputs (up to 8) are required.

The iHP power system offers developers either an analog or digital interface to their system supporting standard communications protocols, while a software graphical user interface (GUI) allows for easy configuration and user dashboard creation.

## SPECIAL FEATURES

- 5 years manufacturer's warranty
- Multi output intelligent and modular high power system
- Standard 19" rack
- Outputs parallel up to 1600 A
- Outputs series up to 1000 V
- 100% digital control
- Outputs program as voltage or current source
- Analog Interface either 0 to 5 V or 0 to 10 V for both current and voltage
- Flexible digital control interfaces (Note 1)
- Semi F47 compliance only when operated at 480 VAC
- Field upgradeable firmware
- Programmable slew rate
- Fast current slew rate up to 200 Hz
- Active power factor correction
- User defined command profiles
- Very low THD

Note 1: Digital Ethernet UDP, RS485, MODBUS, CAN or Ethernet TC/IP with PowerPro Connect Module option. Command protocol is patterned to PMBus specification using a proprietary transaction protocol.

## AT A GLANCE

### Total Power

Up to 20 KW per 4U rack

### Input Voltage

342 to 528 VAC 3-Phase

### # of Outputs

Single output nominal

Up to 8 outputs per modification

**iHP-Liquid**

## SAFETY FOR iHP LIQUID COOLED RACK iHP20SH3LC

- UL 62368-1 Listed
- CSA 62368-1 Listed
- EN 62368-1
- IEC 62368-1
- CE (LVD+RoHS), EN 62368-1

**iHP20 - LIQUID ELECTRICAL SPECIFICATIONS**

Input Parameter	19" Rack 20 kW strapped as 3-phase 380/480 VAC Nominal (iHP20SH3LC)
Input range	342 VAC to 528 VAC Nominal rating 380/480 VAC
Number of phases	3-phase (Wye or Delta) 4 wire total (3-phase and 1 protective earth ground)
Frequency	47-63 Hz
Phase detection	Loss of phase will inhibit unit off. Housekeeping/comms must continue with phase loss.
Max current/phase	51 A @ 342 VAC 40 A @ 432 VAC
Undervoltage detection	Nominal input locked on at turn-on. Undervoltage shutdown at 15% below nominal. Turn-on at 12% below nominal. Not to interfere with SEMI F47 specs.
Current inrush	2.5 x Max input current
Power factor	> 0.98 @ full load and nominal line
Harmonic distortion	THD < 13%, PWHD < 22% (refer to EN 61000-3-12)
Line interruption	Designed to meet SEMI F47-0706, 53, 58, S14 at nominal input voltages (Non "S" models don't apply)
Input leakage current	< 2.5 mA (Note for fixed condition 3rd edition leakage = 5 mA)
Power switch	Front panel power switch provided
Input protection	Internal fuse (not user serviceable)
Input overvoltage protection	Up to 115% of nominal input shall not damage unit
Phase imbalance	≤ 5%
Rack parallel	Up to 6 racks (144 KW)
Efficiency	94.1% @ 3P 380 VAC 50% Load 94.8% @ 3P 480 VAC 50% Load
Standby voltage	5 V
Standby regulation	4.75 to 5.25 V
Standby max current	1 A

## EMC/IMMUNITY

EMC		Both Models			
ESD		EN61000-4-2 (IEC1000-4-2)			
Fast Transients		EN61000-4-4 (IEC1000-4-4)			
Surge Immunity		EN61000-4-5 (IEC1000-4-5)			
Conducted Immunity		EN61000-4-6 (IEC1000-4-6)			
Radiated Immunity		EN61000-4-3 (IEC1000-4-3)			
Power Frequency Magnetic Field		EN61000-4-8			
Voltage Dips, Short Interruptions and Voltage Variations		EN 61000-4-34			
Conducted Emission		EN55011, FCC CFR 47, Part 15, Subpart B			
Radiated Emission		EN55011, FCC CFR 47, Part 15, Subpart B			
Category	Standard	Frequency	Level / Limits	PSU Performance Criteria <sup>1</sup>	
Radiated Emissions	EN 55011/CISPR11	30MHz - 1GHz	Class A	-	
	FCC CFR 47, Part 15, Subpart B	30MHz - 1GHz	Class A	-	
		>1GHz (see standard)		-	
Conducted Emissions	EN 55011/CISPR11	150KHz - 30MHz	Class A		
Power Line Harmonics <sup>2</sup>	EN 61000-3-12	See standard	See standard		
Voltage Fluctuations <sup>2</sup>	EN 61000-3-11	See standard	See standard		
Radiated Immunity	EN 61000-4-3	80MHz - 2GHz	10 V/meter	A	
ESD	EN 61000-4-2		8 KV contact	A	
			15 KV Air		
Electrical Fast Transient	EN 61000-4-4		+/- 4 KV	A	
Surge AC	IEEE62.41		EN 61000-4-5	2 KV DM, 4 KV CM	A
				2 KV DM, 2 KV CM	A
				6 KV, CM & DM	Fail Safe
Conducted Immunity	EN 61000-4-6	150 KHz - 80 MHz	10 Vrms	A	
Voltage Dips and Sags <sup>3</sup>	EN 61000-4-34	>95% reduction for	0.5 Cycle	A	
		100% reduction for	0.5 Cycle (45deg phase angle)	A	
		100% reduction for	1 Cycle (0deg phase angle)	C	
		30% reduction for	25/30 Cycles <sup>4</sup>	C	
		30% reduction for	25/30 Cycles <sup>4</sup> (0deg phase angle)	C	
		>95% reduction for	250/300 Cycles <sup>5</sup>	C	
		100% reduction for	250/300 Cycles <sup>5</sup>	C	
Power Frequency Magnetic Field	IEC 61000-4-8	See standard	See standard		

## Notes:

1. Performance criteria of EN61000-4-X standards as defined by EN55024.

2. Applies to AC power supplies only.

3. 24 KW load conducted EMI tests using 48 V modules only. 3 KW load comparative test for other module variants is ok.

4. 25 cycles for 50 Hz test, 30 cycles for 60 Hz test

5. 250 cycles for 50 Hz test, 300 cycles for 60 Hz test

**OUTPUT – GENERAL SPECS**

Parameter								
MODULE CODE	SL	SQ	ST	SW	S8	S1	SA	S2
# Outputs	1	1	1	1	1	1	1	1
Nominal O/P (V)	12.0 V	24.0 V	32.0 V	48.0 V	80.0 V	125.0 V	200.0 V	250.0 V
Max Power (W)	2400 W	2880 W	2880 W	3000 W	3000 W	3000 W	3000 W	3000 W
O/P Current Range (A)	0.0 A - 200 A	0.0 A - 120 A	0.0 A - 90 A	0.0 A - 62.5 A	0.0 A - 37.5 A	0.0 A -24 A	0.0 A - 15.0 A	0.0 A -12 A
Power Density (W/cu-in)	32.5	39.0	39.0	40.6	40.6	40.6	39	40.6
Module Input Voltage	400 V							
Module Operating Temp	-0 °C to +65 °C; Baseplate Temp TBD							
Series Operation	250 V modules can be connected in series up to 1000 V for ITE							
Parallel Operation	8 modules are connected in parallel for single output configuration, with up to 6 racks connected in parallel Single Wire Parallel connection will be provided as part of configuration							

## OUTPUT – MODULE IN VOLTAGE SOURCE MODE

Voltage Source								
MODULE CODE	SL	SQ	ST	SW	S8	S1	SA	S2
Nominal Output (V)	12	24	32	48	80	125	200	250
Setting Range (V)	0.6 V - 14.4 V	1.2 V - 28.8 V	1.6 V - 38.4 V	2.4 V - 57.6 V	4.0 V - 96.0 V	6.25 V - 150.0 V	10.0 V - 240.0 V	12.5 V - 300.0 V
Low Frequency RMS Ripple (mV)	24	48	64	96	160	250	500	500
Line Regulation (mV)	12	24	32	48	80	125	200	250
Load Regulation (mV)	24	48	64	96	160	250	400	500
P-P Ripple (mV)	60	120	160	240	400	625	1250	1250
Drift (Temp Stability)	±0.05% of $I_{out}$ Rated over 8 hours, after 30 minute warm up, constant Line, Load and Temp							
Temp Coefficient (PPM/°C)	200							
Pgm Accuracy (mV)	Digital: 0.1% of Nominal Output Voltage; Analog: 1.0% of Nominal Output Voltage							
Pgm Resolution (mV)	SL=TBD; SQ=1; SW=2; S8=8; S1=6; S2=21							
Meas Accuracy (mV)	0.2% + 0.2% of Nominal Output Voltage							
Meas Resolution	SL=TBD; SQ=1; SW=2; S8=8; S1=6; S2=21							
Transient Response	Max 5.0% deviation from current set point must recover within 1mS for a 50% step load.							
Current Sense Method	Internal Shunt; External Shunt can be used for better temperature stability.							

**OUTPUT – MODULE IN CURRENT SOURCE MODE**

Current Source - Programmable load compensation available for resistive and inductive loads; capacitive load applications; and LED drive applications								
MODULE CODE	SL	SQ	ST	SW	S8	S1	SA	S2
Nominal Output (V)	12	24	32	48	80	125	200	250
Setting Range (A)	0.0 A - 200 A	0.0 A - 120 A	0.0 A - 90 A	0.0 A - 62.5 A	0.0 A - 37.5 A	0.0 A - 24 A	0.0 A - 15 A	0.0 A - 12 A
RMS Ripple (mA)	200	120	90	62.5	37.5	24	15	12
Line Regulation (mA)	200	120	90	125	93.75	48	50	24
Load Regulation (mA)	800	480	375	250	150	96	56	48
P-P Ripple (mA)	N/A							
Drift (Temp Stability)	±0.05% of I <sub>out</sub> Rated over 8 hours, after 30 minute warm up, constant Line, Load and Temp							
Temp Co-efficient (PPM/°C)	SL, SQ = 300 PPM; All other modules are 200 PPM. Temp Co-efficient at rack level is [Temp Co-efficient (module level)] + [4500 PPM of I <sub>out</sub> -max]							
Pgm Accuracy (A)	0.7% digital, 1.3% analog of rated output max							
Pgm Resolution (mA)	79.2	26.4		13.2	10	5.2	2.6	2.6
Meas Accuracy	0.7% + 0.7% of Rated Output Max							
Meas Resolution	79.2	26.4		13.2	10	5.2	2.6	2.6
Transient Response	0-63% output current change in 7.5 mSec, residual value 1%, settling time 35 mSec							
Current Sense Method	Internal Shunt / External Shunt							

Note: Modules are shown with their individual ratings for use with Parallel and series connections.

## ENVIRONMENTAL SPECIFICATIONS

Operating Conditions	ALL MODELS (Unless Otherwise Specified)
Operating Temperature	0°C to +50°C at 100% rated load.
Storage Temperature	-40 °C to +85 °C. For Liquid Cooled models, liquid must be drained before storage
Operating Humidity	20% - 90% non condensing
Storage Humidity	10% - 95% non condensing
Operating Altitude	Up to 9,842 feet above sea level (3,000 meters)
Storage Altitude	Up to 30,000 feet above sea level (9,144 meters)
Vibration	Operating Sinusoidal Vibration MIL-STD-810G Method 528 Procedure I (Type 1): NEBS Office Vibration Environment, Alternate Procedure Operating Random Vibration: IPC-9592B Class 1 Non-Operating Vibration (Packaged): IPC-9592B Class 1; MIL-STD-810G, Method 514.6, Procedure 1, Category 7, Table 514.6C-VII General Exposure
Shock	MIL-STD-810G Method 516.6 Procedures I, II, IV, VI
Shipping and Handling	NSTA for <100 lbs; MIL-STD-2073-1 >100 lbs
Cooling and Audible Noise	Sealed Outer Box: Natural Convection (No Radiation) Cooling Liquid: 30% Ethylene Glycol Flowrate: 26 Deg C inlet temp @ 4.1 - 7.5 L/min EQ Cu Tube Diameter: 10 mm Outer Diameter (7.65mm Inner Diameter) Internal Air-Heat Exchanger design: 1 mm AL fins 2/3 mm spacing (approx. 103 Total Fins)
Ingress Protection	IP54
Pollution Degree	TBD
RoHS Compliance	Yes

ORDERING INFORMATION

CASE CODE		MODULE CODES		PARALLEL/SERIES CASE CODE		CONF CODE	MOD CODE
iHP**XYA-		-XYZ* (x4/x8)		-XX-**		-X	-XXX
Case Decoder	iHP**XYA	Module Decoder	XVZ	First Digit	Second Digit	Special Configuration	Factory Assigned
** = Case Power		X = Output Type		0 = None	0 = None		
	20S = 20 kW 19" Rack Short		S = Single O/P (1-Slot)	1 = Slot 1&2	P = Parallel	Blank = Standard Configuration Alpha Character = Special Set-up	
				2 = Slot 2&3	S = Series		
				3 = Slot 3&4	1 = Combo 2 P/S		
X = Voltage Range		V = Nominal Voltage		4 = Slot 4&5	2 = Combo 2 S/P		
			A = 200V	5 = Slot 5&6	3 = Combo 3 P/P/S		
	H = High Range 342-528		B = Future	6 = Slot 6&7	4 = Combo 3 P/S/P		
			C = Future	7 = Slot 7&8	5 = Combo 3 P/S/S		
Y = Input Phase			D = Future	8 = Slot 1,2&3	6 = Combo 3 S/P/P		
			L = 12 V	9 = Slot 1,2,3&4	7 = Combo 3 S/P/S		
	3 = 3-Phase		Q = 24 V	A = Slot 1,2,3,4&5	8 = Combo 3 S/S/P		
Z = Cooling			T = 32 V	B = Slot 1,2,3,4,5&6	9 = Combo 4 P/P/P/S		
	L = Liquid Cooling		W = 48 V	C = Slot 1,2,3,4,5,6&7	A = Combo 4 P/P/S/P		
			8 = 80 V	D = Slot 1,2,3,4,5,6,7&8	B = Combo 4 P/P/S/S		
A = Accessory Options			1 = 125 V	E = Slot 1&2; 3&4	C = Combo 4 P/S/P/P		
	C = Factory configured (only)		2 = 250 V	F = Slot 1&2; 3&4; 5&6	D = Combo 4 P/S/P/S		
	1-9 = Future		3 = 300 V (12 KW ONLY)	G = Slot 1&2; 3&4; 5&6; 7&8	E = Combo 4 P/S/S/P		
			5 = 500 V (12 KW ONLY)	H = Slot 1,2&3; 4&5	F = Combo 4 P/S/S/S		
		Z=Mode	Blank = Standard	K = Slot 1,2&3; 4,5&6	H = Combo 4 S/P/P/S		
			P = Precision	L = Slot 1,2&3; 4,5&6; 7&8	J = Combo 4 S/P/S/P		
				M = Slot 1,2,3&4; 5&6	K = Combo 4 S/P/S/S		
				N = Slot 1,2,3&4; 5&6; 7&8	L = Combo 4 S/S/P/P		
				P = Slot 1,2,3&4; 5,6&7	M = Combo 4 S/S/P/S		
				R = Slot 1,2,3&4; 5,6,7&8	N = Combo 4 S/S/S/P		
				S = Slot 1,2,3,4&5; 6&7			
				T = Slot 1,2,3,4&5; 6,7&8			
				U = Slot 1,2,3,4,5&6; 7&8			
				Z=Special Defined by MOD Code			
				-** is allowed for secondary series/parallel code			
				1 = Groups 1&2	P = Parallel		
				8 = Groups 1,2&3	S = Series		
				9 = Groups 1,2,3&4	1 = Combo 2 P/S		
				E = Groups 1&2; 3&4	2 = Combo 2 S/P		



**ORDERING INFORMATION (CONTINUED)****MODEL NUMBER SHORTCUT**

For repeated like modules in parallel or series, instead of listing all the same modules separated by a “-”, you can simply list the module once and then follow by the number of times it repeats enclosed in parenthesis.

For example:

**iHP20SH3L-S8-S8-S8-S8-S8-S8-S8-S8-DP**

would become:

**iHP20SH3LC-S8(8)-DP**

**EXAMPLE OF CREATING A PART NUMBER**

If a 300V @ 67A output was desired, the best choice would be using four 80V modules tied in series which have a programming range of 4V to 96V so in series the range is 16V to 384V. To get the current required then tie 2 groups of these series modules into parallel. The final part number would be iHP20SH3LC-S2(8)-RS-1P.

CASE SPECS - OUTLINE DETAIL

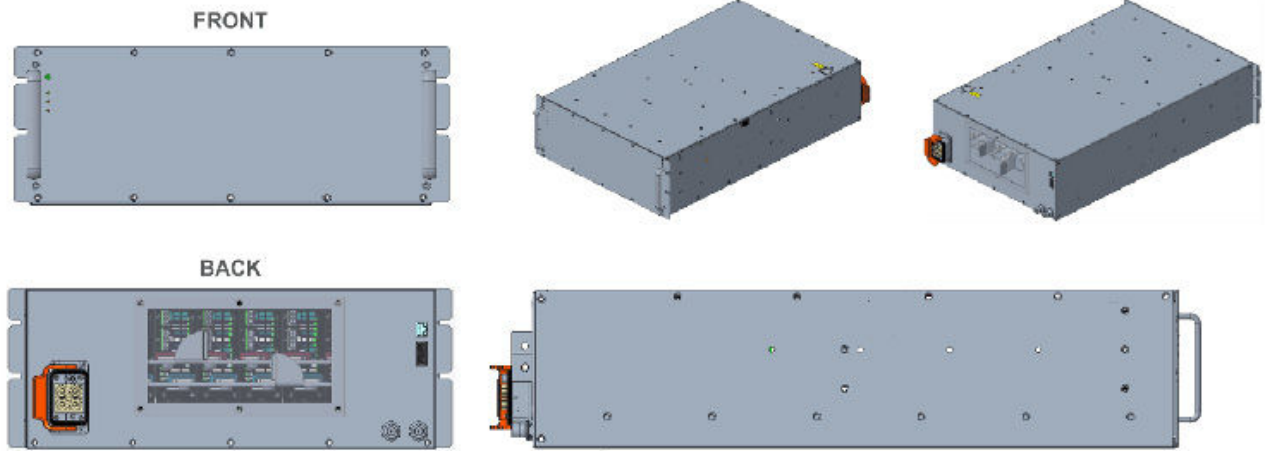

Condition	POWER LED	OUTPUT LED	SYSTEM STATUS LED
No AC	OFF	OFF	OFF
ISOCOMM Start-Up Boot Load	BLINKING GREEN	OFF	OFF
SLEEP Mode (ON/OFF switch)	AMBER	OFF	OFF
Global Inhibit	SOLID GREEN	BLINKING GREEN	OFF
AC GOOD	SOLID GREEN	X	X
AC FAULT (OV, UV)	SOLID RED	OFF	SOLID RED
Output GOOD	SOLID GREEN	SOLID GREEN	SOLID GREEN
Auto-recoverable Fault (OTP)	SOLID GREEN	OFF	SOLID AMBER
Latching Fault (OVP, UVP) or Internal Fault	SOLID GREEN	OFF	SOLID RED
FAN FAIL	SOLID GREEN	OFF	BLINKING RED
BOOTLOADING	X	OFF	BLINKING AMBER

IHP24 LIQUID COOLED RACK - MECHANICAL DRAWINGS

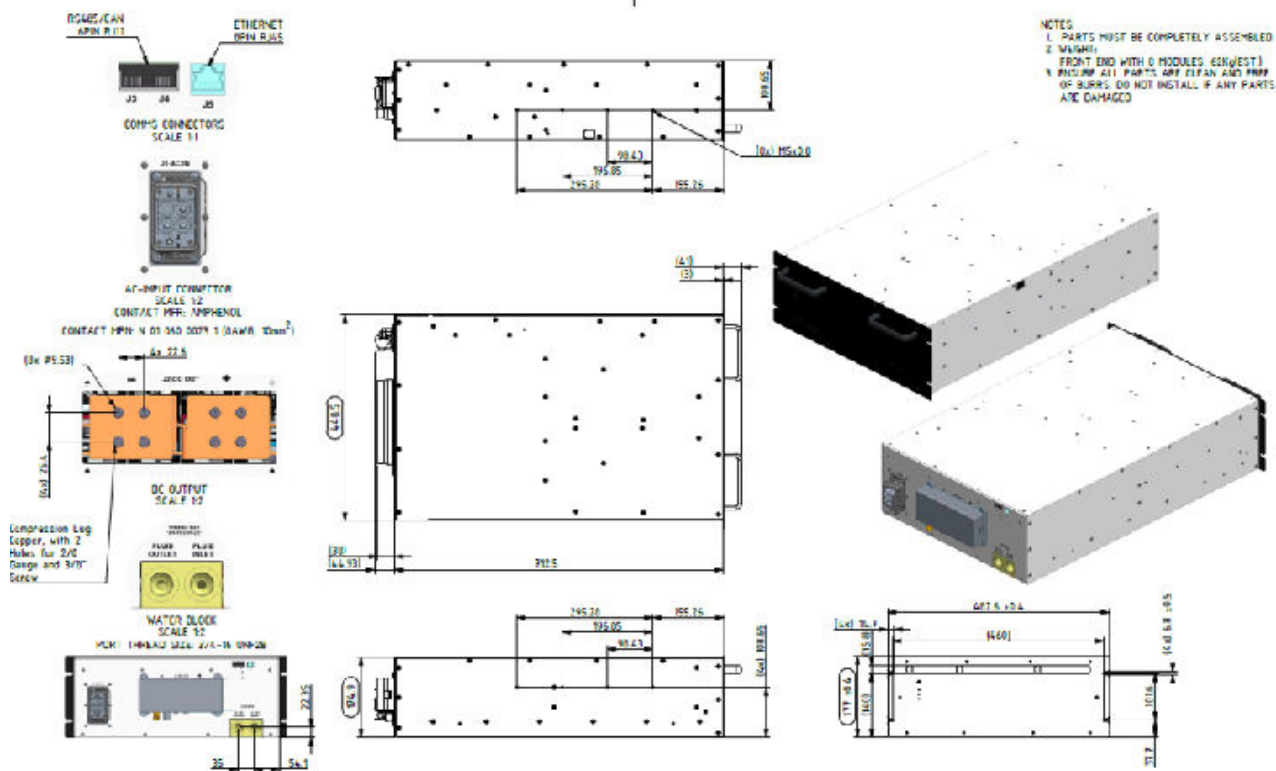

**IHP MODULES FOR REFERENCE ONLY**

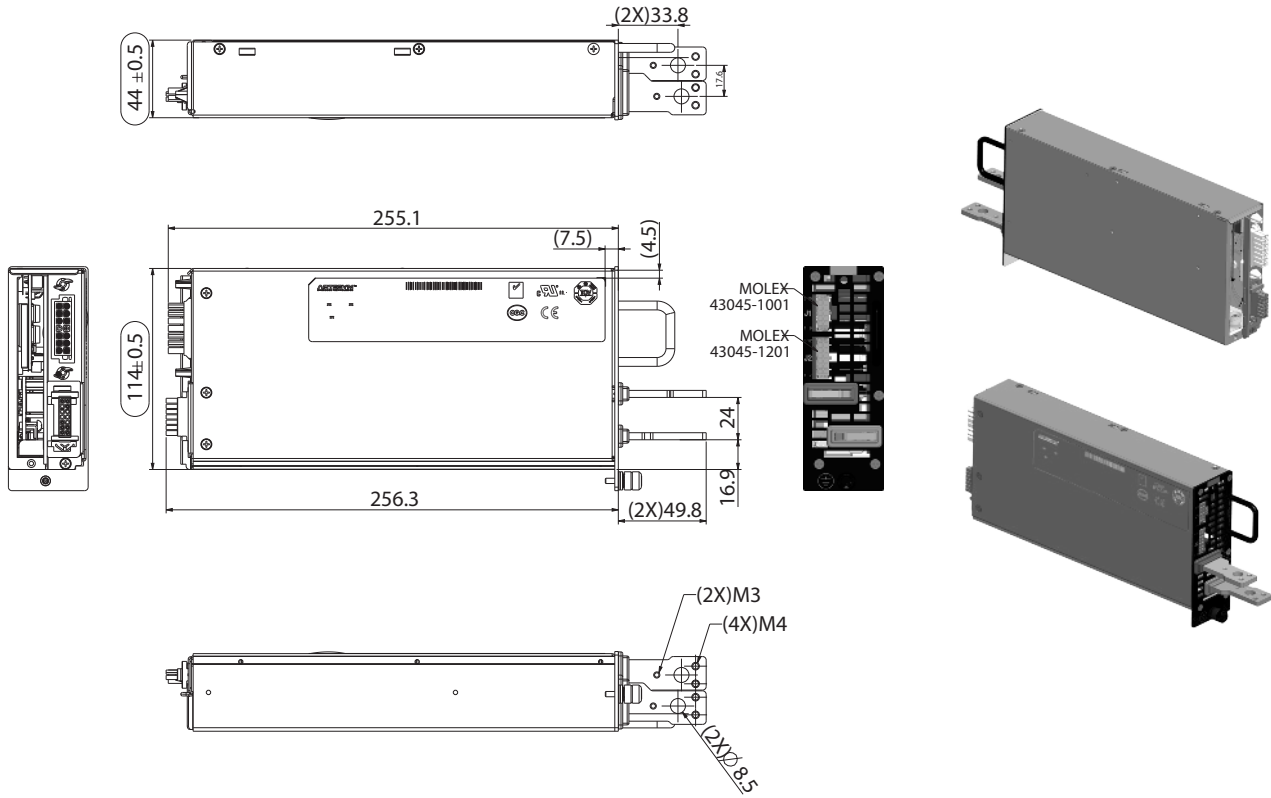

Note : Weight : 3 kW module 12 V – 32 V – 2.2 Kg  
 3 kW module 48 V – 300 V – 2.0 Kg

**POWERPRO CONNECT MODULE**



**POWERPRO**

**Part number:73-778-000A**

The PowerPro Connect Module (purchased separately) can provide standard Ethernet interface via the internet to a cloud- and dashboard-based user-configurable GUI.



For international contact information,  
visit [advancedenergy.com](http://advancedenergy.com).

[powersales@aei.com](mailto:powersales@aei.com) (Sales Support)  
[productsupport.ep@aei.com](mailto:productsupport.ep@aei.com) (Technical Support)  
+1 888 412 7832

## ABOUT ADVANCED ENERGY

Advanced Energy (AE) has devoted more than three decades to perfecting power for its global customers. AE designs and manufactures highly engineered, precision power conversion, measurement and control solutions for mission-critical applications and processes.

Our products enable customer innovation in complex applications for a wide range of industries including semiconductor equipment, industrial, manufacturing, telecommunications, data center computing, and medical. With deep applications know-how and responsive service and support across the globe, we build collaborative partnerships to meet rapid technological developments, propel growth for our customers, and innovate the future of power.

**PRECISION | POWER | PERFORMANCE | TRUST**

---

Specifications are subject to change without notice. Not responsible for errors or omissions. ©2023 Advanced Energy Industries, Inc. All rights reserved. Advanced Energy®, AE® and Artesyn™ are U.S. trademarks of Advanced Energy Industries, Inc.