

VCCR300 Series

USER MANUAL

Single Output Conduction Cooled DC/DC



7.43" x 4.6" x 1"

Low Profile

300W | 600W | 900W

Scalable

33.6-160V_{DC}

Wide input voltage range

Fan-less

Reliable

Ruggedised for long term reliability

The VCCR300 series user manual has been prepared by our design team to assist qualified engineers in correctly designing in the VCCR300 product into their application to achieve the best reliability and performance possible.

All specifications are believed to be correct at time of publishing. Vox Power Ltd reserves the right to make changes to any of its products and to change or improve any part of the specification, electrical or mechanical design or manufacturing process without notice. Vox Power Ltd does not assume any liability arising out of the use or application of any of its products and of any information to the maximum extent permitted by law. No license, express or implied, by estoppel or otherwise, to any intellectual property rights is granted by this document or by any products of Vox Power Ltd. VOX POWER LTD DISCLAIMS ALL WARRANTIES AND REPRESENTATIONS OF ANY KIND WHETHER EXPRESS OR IMPLIED, INCLUDING, BUT NOT LIMITED TO, IMPLIED WARRANTIES OF SUITABILITY, FITNESS FOR PURPOSE, MERCHANTABILITY AND NON-INFRINGEMENT.

Please consult your local distributor or Vox Power directly to ensure that you have the latest revision before using the product and refer to the latest relevant user manual for further information relating to the use of the product. Unless specifically otherwise agreed in writing by Vox Power, products sold by Vox Power are not intended for use in connection with life support systems, human implantations, nuclear facilities or systems, aircraft spacecraft, military or naval missile, ground support or control equipment used for the purpose of guidance navigation or direction of any aircraft spacecraft or military or naval missile or any other application where product failure could lead to loss of life or catastrophic property damage. The user will indemnify and hold Vox Power harmless from any loss, cost or damage resulting from its breach of the provisions.

VCCR300 Series Overview



The VCCR300 series of conduction cooled power supplies have been designed to provide a rugged and highly reliable DC/DC power source that can deliver a silent 300 Watts of power in a 7.43 x 4.6 x 1-inch low profile package. The input voltage has a wide range of 33.6V to 160V which covers the full requirements for the standard 48V, 72V, 96V and 110V railway battery voltages outlined in EN50155 and suitable for a variety of Battery Electric Vehicle (BEV) and other demanding industrial applications. The high efficiency design minimises heating resulting in a wide operating temperature range of -40°C to +70°C (+85°C 10 mins) with minimal cooling requirement. Output voltages of 12V, 24V, 36V and 48V are available with a wide adjustment range of 90% to 125%. Protections including over-voltage, over-current and over-temperature are provided while DC_OK and warning signals indicate the status of the PSU. An adjustable droop mode current share allows multiple units to be paralleled while sharing the load equally. Internal fusing and 10ms full power holdup are included as standard. A remote shutdown signal can place the unit in a low power standby mode and the input undervoltage level can be adjusted to meet application requirements. The series meets the requirements of the latest railway standards (EN50155), MIL-STD-810G (Shock & Vibration) and is approved to the latest industrial safety standards (IEC/UL62368-1 3RD Edition). EMC emissions and immunity exceed the requirements of EN50121-3-2, EN55035 and EN55032 class B. As with all Vox products, our world class sales, applications and engineering teams are available to support design-in of the VCCR300 series.



Contents

VCCR300 Series Overview	1
Contents	2
Part Numbers and Ordering Information	3
Installation Notes	4
Product Operation	10
User controls	13
Efficiency Performance	14
Mechanical Dimensions and Mounting	15
Safety	16
EMC Compliance	17
Reliability	18
Installing your VCCR300 Product	19

Part Numbers and Ordering Information

SUMMARY SPECIFICARIONS									
Model	V _{NOM} (V)	V _{MIN} (V)	V _{MAX} (V)	I _{RATED} (A)	P _{RATED} (W)	V _{OVP} (%V _{SET})	V _{SCP} (%V _{SET})	I _{OCP} (%I _{RATED})	Efficiency ⁽¹⁾ (%)
VCCR300-12	12	10.8	15	25	300	115	60	110	92
VCCR300-24	24	21.6	30	12.5	300	115	60	110	93
VCCR300-36	36	32.4	45	8.33	300	115	60	110	93
VCCR300-48	48	43.2	60	6.25	300	115	60	110	93

1. Vin = 110V, Vo = V_{NOM}, 100% load.

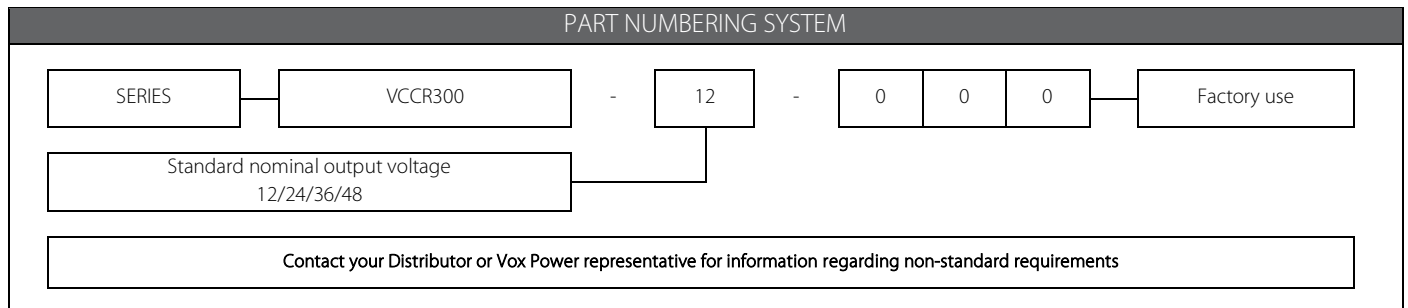



Installation Notes

The instructions in this manual and all warning labels on the product must be followed carefully.



PRODUCT USE

Vox Power Ltd products are not intended for use in connection with life support systems, human implantations, nuclear facilities or systems, aircraft, spacecraft, military or naval missile, ground support or control equipment used for the purpose of guidance navigation or direction of any aircraft, spacecraft or military or naval missile or any other application where product failure could lead to loss of life or catastrophic property damage. The user will hold Vox Power Ltd harmless from any loss, cost or damage resulting from its breach of these provisions.

INSTALLATION

This power supply has been designed in accordance with the relevant safety requirements of IEC/EN/UL/CSA 62368-1, Low voltage Directive LVD 2014/35/EU and EMC directive EMC 2014/30/EU.

The power supply is considered a component power supply and must be installed within an end equipment by qualified personnel. The end equipment must provide a controlled environment which restricts access to any unauthorised personnel. Equipment and system manufacturers must protect operators and service personnel against unintentional contact with hazardous terminals.

HAZARDS

	<p>Risk of electric shock This power supply contains dangerous voltages. Appropriate protections must be implemented.</p>		<p>Hot Surface The external surfaces of this power supply may become hot during and after use. Appropriate protections must be implemented.</p>
--	--	--	--

If series and/or parallel combinations of outputs exceed safe voltage and/or energy levels, the final equipment manufacturer must provide appropriate protection for both users and service personnel.

SYSTEM LABELING

A label that is clearly visible to service personnel must be placed on the final equipment, which warns that surfaces of the power supply may be hot and should not be touched when the product is operating.

Where the incoming wiring earth is intended for connection as the main protective earth conductor and where the terminals for such a connection is not supplied on a component or subassembly, the user shall add an appropriate label displaying a protective earth symbol in accordance with IEC60417-5019 (2006-08) directly adjacent to the terminal.

All labels should be durable and legible and should withstand the 15 second rub test as per UL60950-1 section 1.7.15.

FUSING

The power supply has internal single pole fusing in the positive line.

Fuses are not replaceable. Damaged units should be returned to Vox Power for analysis and repair.

DE-RATINGS

Thermal	None. The unit can supply full power over the entire rated temperature range.
Input Voltage	None. The unit can supply full power over the entire rated input voltage range.

Remember to take the appropriate de-rating into consideration before specifying any power supply for an application. If in any doubt, please contact Vox Power directly or your local Vox Power representative.

SERVICING

This power supply contains no user serviceable parts. Repairs must be carried out by authorised personnel only. Contact Vox Power Ltd for further information.

COOLING

For proper operation of the power supply, the user must ensure all component temperatures are within specifications. A thorough review of the user manual should be carried out for details of thermal performance.

END OF LIFE DISPOSAL

This power supply may contain components that require special disposal. At end of life, ensure that the unit is disposed of according to local regulations.

OTHER

- To prolong the life of the unit, use in a dust free environment.
- If units are damaged during transit, contact your sales agent or Vox Power and DO NOT apply power to the unit.
- Always use adequately sized cables and ensure good crimp connections. Use cable supports to minimise stress on connectors.
- Avoid excessive shock or vibration.

GENERAL INSTALLATION PARAMETERS

- | | | | |
|-----------------------|------------|-------------------------|------------------------|
| • Equipment class | I | • Installation category | II |
| • Pollution degree | 2 | • Material group | IIIb (Indoor use only) |
| • Flammability rating | 94V-2 | • IP rating | IP30 |
| • RoHS compliance | 2011/65/EU | | |



Installationshinweise

Die Anweisungen in dieser Anleitung und alle Warnhinweise auf dem Produkt sind sorgfältig zu befolgen.

PRODUKTVERWENDUNG

Produkte von Vox Power Ltd sind nicht vorgesehen für den Gebrauch in Zusammenhang mit Lebenserhaltungssystemen, menschliche Implantaten, Nuklearanlagen oder -systemen, Flugzeugen, Raumfahrzeugen, militärischen Lenkflugkörpern, boden- oder steuerungstechnischem Gerät für den Einsatz zum Zwecke der Navigation oder Lenkung von Flugzeugen, Raumfahrzeugen oder Lenkflugkörpern oder sonstigen Anwendungen, bei denen ein Produktversagen zum Tode oder zu katastrophalen Schäden führen kann. Der Anwender wird Vox Power Ltd von jeglichen Verlusten, Kosten oder Schäden schadlos halten, die auf die Verletzung dieser Bestimmungen zurückzuführen sind.

INSTALLATION

Diese Netzteil entspricht in Auslegung und Konstruktion den einschlägigen Sicherheitsanforderungen gemäß DIN EN IEC 62368-1, Niederspannungsrichtlinie 2014/35/EU und EMV-Richtlinie 2014/30/EU.

Das Netzteil wird als Einbauteil betrachtet und muss daher von einer Elektrofachkraft in ein Endgerät eingebaut werden. Das Endgerät muss eine geschützte Umgebung/Umhäusung aufweisen, die den Zugang für unbefugte Personen beschränkt. Geräte- und Anlagenhersteller müssen Bedien- und Wartungspersonal vor unbeabsichtigtem Kontakt der gefährlichen Anschlüsse schützen.

GEFAHREN

	<p>Gefahr durch elektrischen Schlag In diesem Netzteil können gefährliche Spannungen anliegen. Es sind geeignete Schutzmaßnahmen vorzusehen.</p>	<p>Heiße Fläche Die äußeren Flächen dieses Netzteils können beim und nach dem Gebrauch heiß werden. Es sind geeignete Schutzmaßnahmen vorzusehen.</p>
--	---	--

Überschreiten in Reihe oder parallel geschaltete Ausgangskombinationen sichere Spannungs- und/oder Energiepegel, hat der Endgerätehersteller für den angemessenen Schutz für Anwender und Wartungspersonal zu sorgen.

SYSTEMKENNZEICHNUNG

Das Endgerät ist mit einem gut für das Wartungspersonal sichtbaren Aufkleber (o. ä.) zu versehen, der davor warnt, dass die Netzteiloberflächen im Betrieb heiß sein könnten und nicht berührt werden sollten.

Ist die eingehende Erdleitung für den Anschluss als Hauptschutzleiter vorgesehen und es sind auf Baugruppen- oder Bauteilebene keine Anschlüsse für einen solchen Anschluss vorhanden, hat der Anwender in unmittelbarer Nähe des Anschlusses einen geeigneten Aufkleber mit dem Symbol Schutzerde gemäß IEC 60417-5019 (2006-08) anzubringen.

Alle Aufkleber müssen dauerhaft und lesbar sein und die 15-Sekunden-Reibprüfung gemäß UL60950-1 Abschnitt 1.7.15 bestehen.

SICHERUNG

Die Stromversorgung verfügt über eine interne einpolige Sicherung im positiven (+) Eingang.

Sicherungen sind nicht auswechselbar. Beschädigte Geräte sollten zwecks Diagnose und Reparatur an Vox Power zurückgesendet werden.

DERATING (Reduzierung von Maximalwerten)

Temperaturen	Keine. Das Gerät kann über den gesamten definierten Temperaturbereich die volle Leistung liefern.
Eingangsspannung	Keine. Das Gerät kann über den gesamten definierten Eingangsspannungsbereich die volle Leistung liefern.

Berücksichtigen bei der Bemessung und Spezifikation jedes Netzteils stets ein entsprechendes Derating. Bei Fragen bitte direkt an Vox Power oder an Ihre zuständige Vertretung für Vox Power wenden.

INSTANDHALTUNG

Reparaturen sind ausschließlich durch befugte Personen durchzuführen. Bei Informationsbedarf bitte an Vox Power Ltd wenden.

KÜHLUNG

Für den ordnungsgemäßen Betrieb des Netzteils muss der Anwender gewährleisten, dass alle Bauteiltemperaturen innerhalb der angegebenen Werte/Spezifikationen bleiben. Lesen Sie sich bitte sorgfältig die Abschnitte bzw. Daten mit Bezug auf das Temperaturverhalten im Gerätehandbuch durch.

ENTSORGUNG

Dieses Netzteil kann Komponenten enthalten, die gesondert entsorgt werden müssen. Bei der Entsorgung des Gerätes sind die jeweils gültigen Vorschriften zu beachten.

SONSTIGES

- Zur Optimierung der Lebensdauer sollte das Gerät in einer staubfreien Umgebung betrieben werden.
- Bei Transportschäden das GERÄT NICHT ANSCHLIESSEN ODER IN BETRIEB NEHMEN. Wenden Sie sich bitte an Ihre Handelsvertretung oder an Vox Power.
- Verwenden Sie stets Kabel mit ausreichenden Querschnitten und achten Sie auf gute Crimpanschlüsse. Verwenden Sie Kabelhalter, um die Steckverbinder möglichst wenig zu beanspruchen.
- Vermeiden Sie übermäßige Stoß- oder Schwingbeanspruchungen.

ALLGEMEINE INSTALLATIONSPARAMETER

• Geräteklasse	I	• Überspannungskategorie	II
• Verschmutzungsgrad	2	• Isolierstoffgruppe	IIIb (nur Innenbereich)
• Entflammbarkeit	UL 94V-2	• Schutzart	IP30
• RoHS-Konformität	2011/65/EU		



Instrucciones de instalación

Las instrucciones de este manual y las etiquetas de advertencia del producto se deben seguir estrictamente.

USO DEL PRODUCTO

Los productos de Vox Power Ltd no están destinados a su conexión a sistemas de soporte vital, implantaciones en personas, instalaciones o sistemas nucleares, aviones, vehículos espaciales, misiles militares o navales, equipamiento de soporte o control terrestre utilizado para guiar la navegación o la dirección de aviones, vehículos espaciales o misiles militares o navales o cualquier otra aplicación en las que una avería del producto pudiera provocar la pérdida de vidas o daños catastróficos en propiedades. El usuario eximirá a Vox Power Ltd de cualquier pérdida, coste o daño resultante del incumplimiento de estas condiciones.

INSTALACIÓN

Esta fuente de alimentación se ha diseñado en conformidad con los requisitos de seguridad correspondientes de IEC/EN/UL/CSA 62368-1, Directiva de Baja Tensión LVD 2014/35/EU y Directiva EMC 2014/30/EU.

La fuente de alimentación se considera un componente que debe ser instalado en un equipo final por personal cualificado. El equipo final debe proporcionar un entorno controlado que limite el acceso al personal no autorizado. Los fabricantes de los equipos y los sistemas deben proteger a los operarios y al personal de mantenimiento frente al contacto accidental con terminales peligrosos.

PELIGROS

	<p>Riesgo de descarga eléctrica Esta fuente de alimentación contiene tensiones peligrosas. Se deben aplicar las protecciones apropiadas.</p>		<p>Superficies calientes Las superficies externas de esta fuente de alimentación se pueden calentar durante y después de su uso. Se deben aplicar las protecciones apropiadas.</p>
---	---	---	---

Si las combinaciones en serie y/o paralelo de las salidas superan los niveles de tensión y/o energía de seguridad, el fabricante del equipo final debe proporcionar la protección apropiada a los usuarios y al personal de mantenimiento.

ETIQUETADO DEL SISTEMA

Se debe colocar una etiqueta sobre el equipo final de manera que sea claramente visible para el personal de mantenimiento. Esta etiqueta advertirá que las superficies de la fuente de alimentación pueden estar calientes y no se deberían tocar cuando el producto está en funcionamiento.

Cuando la entrada de la toma de tierra esté destinada a la conexión como conductor a tierra de protección principal y los terminales para esta conexión no hayan sido suministrados en un componente o subsistema, el usuario añadirá una etiqueta apropiada que indique un símbolo de toma de tierra de protección en conformidad con IEC60417-5019 (2006-08) y la colocará al lado del terminal.

Todas las etiquetas deben ser resistentes y legibles, y deben superar la prueba de rasgado durante 15 segundos de UL60950-1 sección 1.7.15.

FUSIBLES

La fuente de alimentación tiene un fusible interno unipolar en la línea positiva.

Los fusibles no son sustituibles. Las unidades averiadas se deben enviar a Vox Power para su análisis y reparación.

DERATING (REDUCCION DE ESPECIFICACIONES)

Térmicas	Ninguno. Este producto puede suministrar la máxima potencia de salida especificada en todo el rango de temperaturas.
Voltaje de entrada	Ninguno. Este producto puede suministrar la máxima potencia de salida especificada en todo el rango de voltajes de entrada.

Recuerde que es necesario reajustar las especificaciones antes de escoger una fuente de alimentación para una determinada aplicación. Si tiene alguna duda, contacte con Vox Power directamente o a través de un representante de la empresa.

REPARACIONES

Esta fuente de alimentación no contiene piezas reparables. Las reparaciones deben ser efectuadas únicamente por personal autorizado. Contacte con Vox Power Ltd para más información.

REFRIGERACIÓN

Para que el funcionamiento de la fuente de alimentación sea adecuado, el usuario debe asegurarse de que la refrigeración sea suficiente para mantener las temperaturas de todos los componentes dentro de sus especificaciones. Revise el manual de usuario para más información.

ELIMINACIÓN AL FINAL DE LA VIDA ÚTIL

Esta fuente de alimentación puede contener componentes que requieren un tratamiento especial al desecharlos. Asegúrese de cumplir la normativa correspondiente cuando finalice la vida útil de la unidad.

OTROS

- Para prolongar la vida útil de la unidad utilícela en un entorno libre de polvo.
- Si las unidades sufren daños durante su traslado, contacte con su representante comercial o con Vox Power y NO alimente la unidad.
- Use siempre los cables del diámetro adecuado y compruebe que conexiones tienen el engarce correcto. Utilice soporte para el cable para minimizar el esfuerzo en los conectores.
- Evite fuertes choques o vibraciones.

PARÁMETROS GENERALES DE INSTALACIÓN

- | | | | |
|---------------------------|------------|----------------------------|------------------------------------|
| • Clase del equipo | I | • Categoría de instalación | II |
| • Grado de contaminación | 2 | • Grupo de material | IIIb (para uso solo en interiores) |
| • Grado de inflamabilidad | 94V-2 | • Grado de IP | IP30 |
| • Conformidad con RoHS | 2011/65/EU | | |



Remarques relatives à l'installation

Les instructions de ce manuel et les étiquettes d'avertissement présentes sur le produit doivent être respectées scrupuleusement.

UTILISATION DU PRODUIT

Les produits Vox Power Ltd ne sont pas destinés à être utilisés dans des systèmes de survie, des implants chirurgicaux, des installations ou systèmes nucléaires, des avions, des engins spatiaux, des missiles militaires ou navals, des équipements de soutien au sol ou de commande utilisés à des fins de guidage, de navigation ou d'orientation d'avion, d'engin spatial ou de missile militaire ou naval, ni dans toute autre application dans laquelle une défaillance du produit pourrait entraîner une perte de vie humaine ou des dommages matériels catastrophiques. L'utilisateur ne saurait tenir responsable Vox Power Ltd de toute perte financière, coût ou dommage résultant du non-respect de ces termes.

INSTALLATION

Cette alimentation est conçue conformément aux exigences de sécurité applicables des normes IEC/EN/UL/CSA 62368-1, de la directive basse tension LVD 2014/35/EU et de la directive CEM 2014/30/EU.

L'alimentation est considérée comme un composant de puissance, et doit être installée dans l'équipement final par du personnel qualifié. L'équipement final doit fournir un environnement contrôlé qui restreint l'accès à toute personne non autorisée. Les fabricants d'équipements et de systèmes doivent protéger les opérateurs et le personnel de service contre tout contact involontaire avec les bornes présentant un danger.

DANGERS

	<p>Risque de choc électrique Cette alimentation contient des tensions dangereuses. Des protections appropriées doivent être mises en place.</p>		<p>Surfaces chaudes Les surfaces externes de cette alimentation peuvent devenir très chaudes pendant et après l'utilisation. Des protections appropriées doivent être mises en place.</p>
---	--	---	--

Si la combinaison en série et/ou en parallèle de sorties multiples amène à dépasser les niveaux de tension et/ou d'énergie sûrs, le fabricant de l'équipement final doit fournir une protection appropriée aux utilisateurs et au personnel de maintenance.

ÉTIQUETAGE DU SYSTÈME

Une étiquette bien visible du personnel de maintenance doit être apposée sur l'équipement final, pour avertir que certaines surfaces de l'alimentation peuvent être chaudes et ne doivent pas être touchées lorsque l'équipement fonctionne.

Lorsque le conducteur de terre du câblage entrant est destiné à être connecté en tant que conducteur principal de protection et que la borne de connexion ne se trouve pas sur un composant ou un sous-ensemble, l'utilisateur doit apposer une étiquette appropriée affichant un symbole de protection conformément à la norme CEI60417-5019 (2006-08) à proximité directe de la borne.

Toutes les étiquettes doivent être durables et lisibles, et résister au test de frottement de 15 secondes conformément à la section 1.7.15 de la norme UL60950-1.

FUSIBLE DE PROTECTION

L'alimentation a un seul fusible interne sur la Phase.

Les fusibles ne sont pas remplaçables Les unités endommagées doivent être retournées à Vox Power pour analyse et réparation.

DÉCLASSEMENT

Thermique	Aucun. Le produit peut fournir une puissance totale sur toute la plage de température nominale.
Tension d'entrée	Aucun. Le produit peut fournir une puissance totale sur toute la plage de tension d'entrée nominale.

N'oubliez pas de tenir compte du déclassement approprié avant de spécifier une alimentation pour une application. En cas de doute, veuillez contacter directement Vox Power ou votre représentant local Vox Power.

MAINTENANCE

Cette alimentation ne contient aucun composant réparable par l'utilisateur. Les réparations ne doivent être effectuées que par du personnel autorisé. Contactez Vox Power Ltd pour plus d'informations.

REFROIDISSEMENT

Pour un fonctionnement correct de l'alimentation, l'utilisateur doit s'assurer que la température de tous les composants reste dans les limites des spécifications. Lire le manuel d'utilisation attentivement pour les détails de performance thermique.

ÉLIMINATION EN FIN DE VIE

Cette alimentation peut contenir des composants nécessitant une procédure d'élimination particulière. En fin de vie, assurez-vous que l'appareil est éliminé conformément aux réglementations locales.

AUTRE

- Pour prolonger la durée de vie de l'appareil, utilisez-le dans un environnement non-poussiéreux.
- Si l'unité a été endommagée durant son transport, contactez votre représentant commercial ou Vox Power, et NE mettez PAS l'unité sous tension.
- Utilisez toujours des câbles de diamètre adéquat et assurez-vous que les connexions soient bien serties et bien serrées. Utilisez des supports de câbles pour minimiser les contraintes sur les connecteurs.
- Évitez les chocs et les vibrations excessives.

PARAMÈTRES D'INSTALLATION GÉNÉRAUX

• Classe d'équipement	1	• Catégorie d'installation	II
• Degré de pollution	2	• Groupe de matériaux	IIIb (intérieur uniquement)
• Indice d'inflammabilité	94V-2	• Indice IP	IP30
• Conformité RoHS	2011/65/EU		



Note per l'installazione



Seguire scrupolosamente le istruzioni del presente manuale e le indicazioni di tutte le etichette di avvertenza presenti sul prodotto.

USO DEL PRODOTTO

I prodotti Vox Power Ltd non sono previsti per l'uso in relazione a sistemi di supporto delle funzioni vitali, impianti su esseri umani, impianti o centrali nucleari, aeroplani, veicoli spaziali, missili navali o per usi militari, apparecchiature di controllo o supporto di sistemi terrestri impiegati per la guida o l'orientamento di qualsiasi aerodina, missili navali oppure per usi militari o veicoli spaziali o qualunque altra applicazione in cui un guasto al prodotto potrebbe comportare la perdita di vite o danni catastrofici alle cose. L'utilizzatore manleva e terrà indenne Vox Power Ltd da qualsiasi perdita, costo o danno risultante dalla violazione di queste disposizioni.

INSTALLAZIONE

Questo alimentatore è stato progettato in conformità ai requisiti relativi alla sicurezza specificati nelle seguenti norme e direttive: IEC/EN/UL/CSA 62368-1, Direttiva 2014/35/UE "bassa tensione" e Direttiva 2014/30/UE relativa alla compatibilità elettromagnetica.

L'alimentatore è considerato un componente di un'apparecchiatura finale e deve essere installato nella stessa da personale qualificato. Tale apparecchiatura deve assicurare un ambiente controllato che limiti l'accesso a personale non autorizzato. I produttori di apparecchiature e sistemi devono proteggere gli operatori e il personale di manutenzione contro il contatto non intenzionale con terminali pericolosi.

RISCHI

	<p>Rischio di folgorazione In questo alimentatore sono presenti alte tensioni. Attuare misure di protezione appropriate.</p>		<p>Superfici ad alta temperatura Le superfici esterne di questo alimentatore possono raggiungere temperature elevate durante e dopo l'uso. Attuare misure di protezione appropriate.</p>
--	---	--	---

Se combinazioni in serie e/o in parallelo delle uscite superano livelli sicuri di tensione e/o energia, il produttore dell'apparecchiatura finale deve garantire una protezione adatta sia per gli utilizzatori che per il personale di manutenzione.

ETICHETTATURA DELL'IMPIANTO

Sull'apparecchiatura finale deve essere apposta un'etichetta, chiaramente visibile dal personale di manutenzione, avvisante che le superfici dell'alimentatore possono raggiungere temperature elevate e non devono essere toccate mentre il prodotto è in funzione.

Nel caso in cui il cavo di terra in ingresso sia concepito per la connessione come principale conduttore di protezione al potenziale di terra e i terminali per tale connessione non siano forniti su un componente o un gruppo secondario, direttamente accanto al terminale l'utilizzatore deve aggiungere un'appropriata etichetta che mostri un simbolo di terra di protezione in conformità alla norma IEC60417-5019 (2006-08).

Tutte le etichette devono essere durevoli e leggibili e devono superare la prova di strofinamento di 15 secondi a norma UL60950-1 sezione 1.7.15.

FUSIBILI

L'alimentatore è dotato di fusibili unipolari interni, situato nella linea positiva.

I fusibili non possono essere sostituiti. Un alimentatore danneggiato deve essere restituito a Vox Power per essere analizzato e riparato.

DERATING

Derating in funzione della temperatura	Nessuno. Questo prodotto può somministrare piena potenza di uscita per tutto il rango di temperatura.
Voltaggi d'ingresso	Nessuno. Questo prodotto può somministrare piena potenza di uscita per tutto il rango di voltaggio d'ingresso.

Prendere in considerazione l'appropriato derating prima di specificare un eventuale alimentatore per un'applicazione. In caso di dubbi, contattare direttamente Vox Power o il rappresentante locale Vox Power.

RIPARAZIONI

Questo alimentatore non contiene parti su cui l'utilizzatore possa intervenire. Eventuali riparazioni devono essere eseguite esclusivamente da personale autorizzato. Per ulteriori informazioni contattare Vox Power Ltd.

RAFFREDDAMENTO

Ai fini del corretto funzionamento dell'alimentatore, l'utilizzatore deve far sì che le temperature di tutti i componenti rimangano entro le specifiche. Leggere con attenzione il manuale per l'uso per informazioni dettagliate sulle prestazioni termiche.

SMALTIMENTO A FINE VITA

Questo alimentatore potrebbe contenere componenti che richiedono uno smaltimento speciale. Al termine della sua durata, accertarsi che venga smaltito in conformità alle norme di legge.

ALTRE INDICAZIONI

- Per prolungare la durata del dispositivo, impiegarlo in un ambiente privo di polvere.
- Se un dispositivo viene danneggiato durante il trasporto, contattare l'agente di vendita locale o Vox Power e NON accenderlo.
- Usare sempre cavi di sezione adeguata e accertarsi che le connessioni siano salde. Usare pressacavo per ridurre al minimo le sollecitazioni sui connettori.
- Evitare urti o vibrazioni di livello eccessivo.

PARAMETRI DI INSTALLAZIONE GENERALI

• Classe apparecchiatura	1	• Categoria di installazione	II
• Grado d'inquinamento	2	• Gruppo materiali	IIIb (solo per l'uso in locali chiusi)
• Grado d'infiammabilità	94V-2	• Grado di protezione involucro	IP30
• Conformità RoHS	2011/65/EU		



Informações sobre a instalação

As instruções neste manual e em todas as etiquetas de aviso afixadas no produto devem ser cuidadosamente observadas

UTILIZAÇÃO DO PRODUTO

Os produtos da Vox Power Ltd não se destinam a ser utilizados em sistemas de suporte de vida, sistemas para implantação no corpo humano, instalações ou sistemas nucleares, aeronaves, naves espaciais, mísseis militares ou navais, equipamento de suporte no solo ou de controlo para fins de guiamento de navegação ou orientação de aeronaves, naves espaciais ou mísseis militares ou navais ou quaisquer outras aplicações onde a falha do produto possa conduzir à perda de vidas ou a danos materiais catastróficos. O utilizar deve isentar a Vox Power Ltd de quaisquer perdas, custos ou danos decorrentes da violação destas disposições.

INSTALAÇÃO

Esta fonte de alimentação foi desenvolvida e construída de acordo com os requisitos de segurança relevantes das normas IEC/EN/UL/CSA 62368-1, Directiva de Baixa Tensão 2014/35 / EU e Directiva de Compatibilidade Electromagnética 2014/30 / EU.

A fonte de alimentação é considerada um componente de alimentação e deve ser instalada no equipamento final por pessoal qualificado. O equipamento final deve assegurar um ambiente controlado que restrinja o seu acesso a pessoal não autorizado. Os fabricantes dos equipamentos e sistemas devem proteger os operadores e o pessoal de manutenção contra os contactos não intencionais com terminais perigosos.

RISCOS

	<p>Risco de choque eléctrico Esta fonte de alimentação contém correntes eléctricas perigosas. Por isso, devem ser utilizadas protecções apropriadas.</p>		<p>Superfície quente As superfícies exteriores desta fonte de alimentação podem ficar quentes durante e após a sua utilização. Por isso, devem ser utilizadas protecções apropriadas.</p>
--	---	--	--

Se as montagens em série e/ou paralelo das saídas excederem os níveis de tensão e/ou energia de segurança, o fabricante do equipamento final deve fornecer protecção adequada para os utilizadores e técnicos de manutenção.

ETIQUETAS AFIXADAS

Deve ser afixado no equipamento final uma etiqueta claramente visível para o pessoal de manutenção, avisando que as superfícies da fonte de alimentação podem estar quentes e não devem ser tocadas quando o produto estiver em funcionamento.

Quando o condutor de terra de entrada se destinar a ser a ligação principal da terra de protecção e se os terminais para tal conexão não forem fornecidos como componente ou subconjunto único, o utilizador deve afixar uma etiqueta adicional directamente adjacente ao terminal com um símbolo de terra de protecção de acordo com a norma IEC60417-5019 (2006-08).

Todas as etiquetas devem ser duráveis e legíveis e devem resistir ao ensaio de abrasão durante 15 segundos, conforme a norma UL60950-1, parágrafo 1.7.15.

FUSÍVEIS

A fonte de alimentação tem um fusível interno unipolar na linha positive. **Os fusíveis não são substituíveis.** Em caso de defeito ou avaria, enviar a fonte de alimentação para a Vox Power, para análise.

REDUÇÃO DOS VALORES NOMINAIS

Térmica	Nenhum. A unidade pode fornecer potência total especificada em todo o intervalo de temperatura.
Tensão de Entrada	Nenhum. A unidade pode fornecer potência total especificada em todo o intervalo de tensão de entrada.

Não esquecer de ter em consideração a redução apropriada, antes de especificar a fonte de alimentação para uma aplicação. Em caso de dúvida, contactar directamente com a Vox Power ou um dos seus Distribuidores.

SERVIÇO E MANUTENÇÃO

Esta fonte de alimentação não contém peças cuja manutenção possa ser feita pelo utilizador. As reparações devem ser realizadas apenas por pessoal autorizado. Para mais informações, contactar a Vox Power Ltd.

ARREFECIMENTO

Para o funcionamento adequado da fonte de alimentação, o utilizador deve assegurar um arrefecimento suficiente para manter as temperaturas de todos os componentes dentro dos parâmetros especificados. Analisar completamente o Manual de Utilização, para obter informações sobre o desempenho térmico.

ELIMINAÇÃO FINAL DO PRODUTO

Esta fonte de alimentação pode conter componentes que exijam uma eliminação final especial. No final da sua vida útil, a fonte de alimentação deve ser eliminada de acordo com os regulamentos locais em vigor aplicáveis.

OUTRAS INSTRUÇÕES

- Para prolongar a vida útil do equipamento, utilizá-lo em ambientes sem poeiras.
- Em caso de danificação do equipamento durante o transporte, contactar o responsável pelo fornecimento ou a Vox Power e NÃO energizar o equipamento.
- Usar sempre cabos de calibre adequado e com boas ligações por cravagem. Suportar devidamente as cablagens, para minimizar as tensões nos conectores.
- Evitar choques ou vibrações excessivas.

PARÂMETROS GERAIS DA INSTALAÇÃO

• Classe de equipamento	1	• Categoria da instalação	II
• Nível de poluição	2	• Grupo de materiais	IIIb (apenas para utilização interior)
• Classe de inflamabilidade	94V-2	• Classe de protecção	IP30
• Certificação RoHS (materiais perigosos)	2011/65/EU		

Product Operation

System overview

The diagram below outlines the topology and major internal components of a VCCR300 power supply.

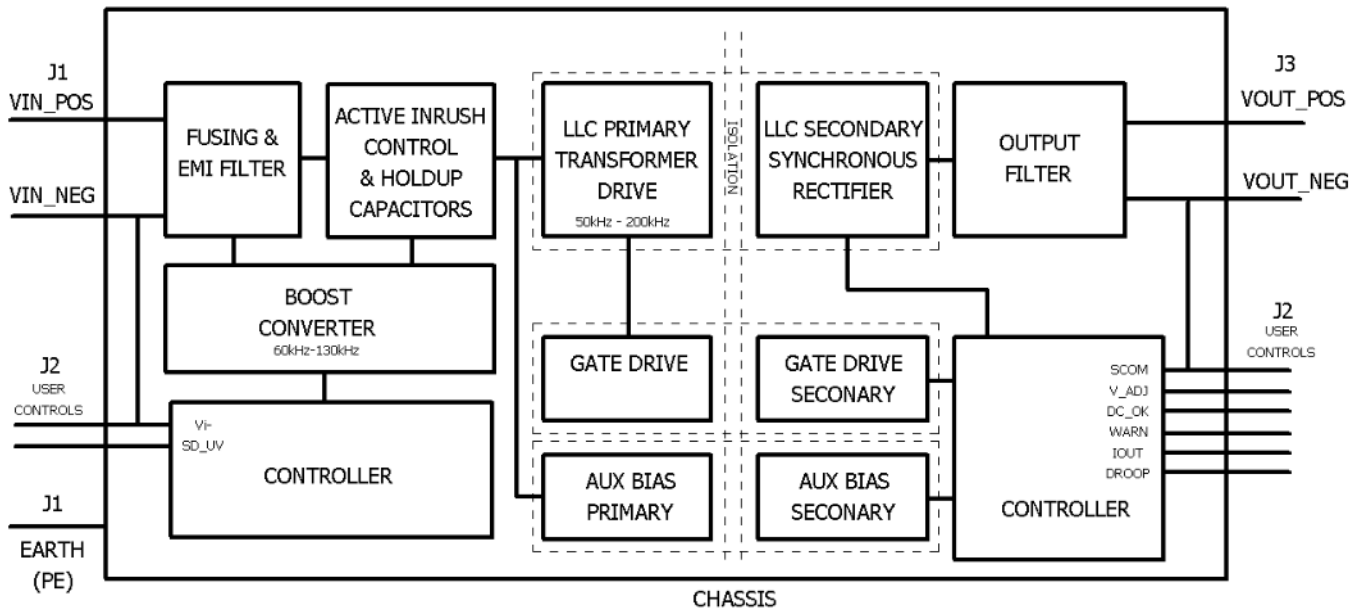

The DC input is fused in the positive line and filtered before being boosted to an appropriate DC voltage. The integrated EMI filter attenuates high frequency current emissions to levels below EN55032 class B and provides protection from input disturbances.

Inrush current into the holdup capacitors is controlled by a resistive element when the unit is initially connected to the DC input. Once the internal capacitances have been charged, the resistive element is bypassed.

The boost converter stage is used to boost the input voltage to a consistent level and to provide active input current limiting which prevents overloading of the input stage. The output of the boost converter stage charges the hold-up electrolytic capacitors which store enough energy to allow the VCCR300 product to continue operating during minor line disturbances. Long lifetime and high temperature capacitors are used which ensures extended lifetime and product reliability.

A highly efficient zero voltage switching circuit is used to drive the LLC transformer from the hold-up capacitors. The output synchronous rectifiers connect to the transformer secondary and provide safe isolated power. This power converter is controlled using the latest analog control technology to produce superior output performance in a miniature size.

Ruggedness and Reliability are designed into every aspect of the product. Components such as opto-couplers and lower reliability electrolytic capacitors have been eliminated from the design. All internal components are dipped in a protective coating as standard. Extensive shock, vibration and accelerated life testing have been carried out to ensure long term reliability of the product.

Startup & Shut Down Timing

The VCCR300 operates from a wide input voltage range and starts automatically upon application of adequate DC input voltage ($>30V_{DC}$). After a short delay the output voltage rises and delivers power to the application loads.

The diagram below shows the normal start-up/shut down sequence and gives typical timings.

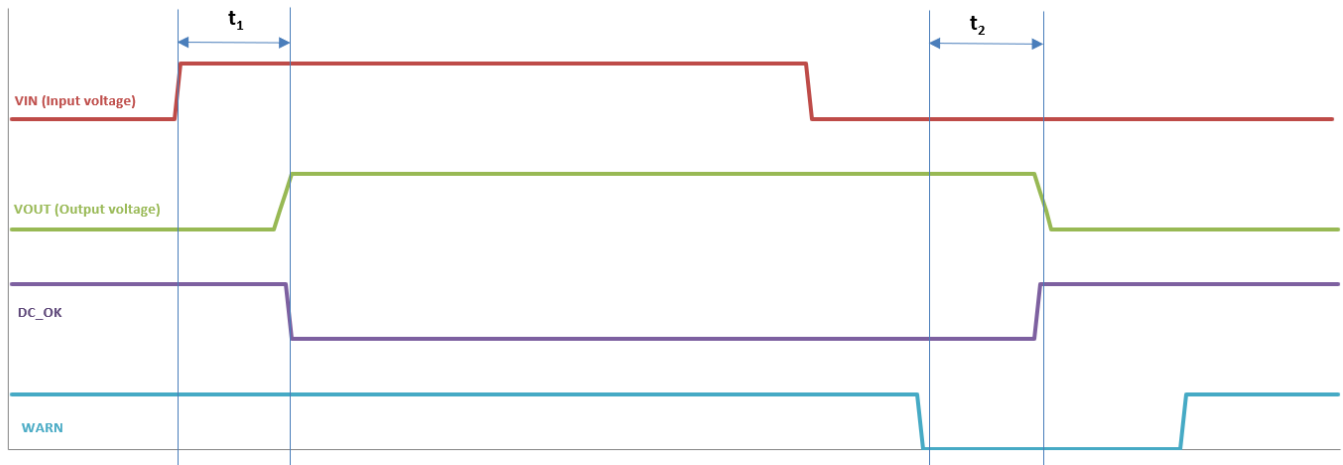

Typical timing values at $48V_{DC}$ 300W 25°C: $t_1 \approx 600$ ms, $t_2 \geq 5$ ms

Hold-up

For short input voltage disturbances (<10 ms, EN50155 Class S2), the unit can deliver full output power (300W) without disturbance on the output voltage. Longer input voltage disturbances can be accommodated by reducing the output power.

E.g. To comply with EN50155 Class S3 input voltage disturbance (<20 ms) the output power should be reduced to 180W.

Inrush current

Inrush current occurs when the input voltage initially rises and charges the internal capacitors of the power supply. Inrush current usually has two stages, firstly the low value EMI differential mode capacitances are charged and then the large bulk hold up capacitors are charged. The VCCR300 has a very low differential EMI filter capacitance of less than $8\mu F$ which minimises the initial inrush current spike. The inrush current into the large hold up capacitors is actively limited to a very low value.

Standby Power Consumption

The VCCR300 series has an extremely low standby current consumption of typically less than 4mA resulting in very low residual discharge from battery systems in standby mode.

No Load Power Consumption

The VCCR300 series has an extremely low no-load power consumption of <1.5 W. To achieve this the unit enters burst mode when the output power is below 3W. When in burst mode the output ripple frequency will reduce significantly.

Input Over Power Protection (OPP)

The input circuitry is protected from excessive input power by means of an over-power protection circuit which limits the input power to approximately 400W. If the OPP threshold is exceeded the unit may shut down and attempt to automatically restart.

Input Under Voltage Protection (UVP)

The input circuitry will not operate until the applied input voltage exceeds the input under voltage threshold. The input under voltage threshold is set to 30V by default but can be programmed by an external resistor. Once the unit is active, the input voltage must drop below the under voltage threshold for 200ms before the unit shuts off.

Over Temperature Protection (OTP)

The unit is protected from excessive temperatures by means of various internal temperature sensors. If temperature thresholds are exceeded the unit may turn off. The unit will automatically recover once it has cooled sufficiently.

Input Reverse Polarity Protection (RPP)

Application of reverse polarity voltage at the input terminals may cause the internal fuse to open. If this occurs the unit must be returned to Vox Power for fuse replacement.

Output Power Profile

The power profile diagram below is a voltage/current plot that together with the associated table provides details of the main features of the standard output voltages. Alternative output voltage constructions are available to order, consult your Vox Power Distributer or Vox Power representative for further details.

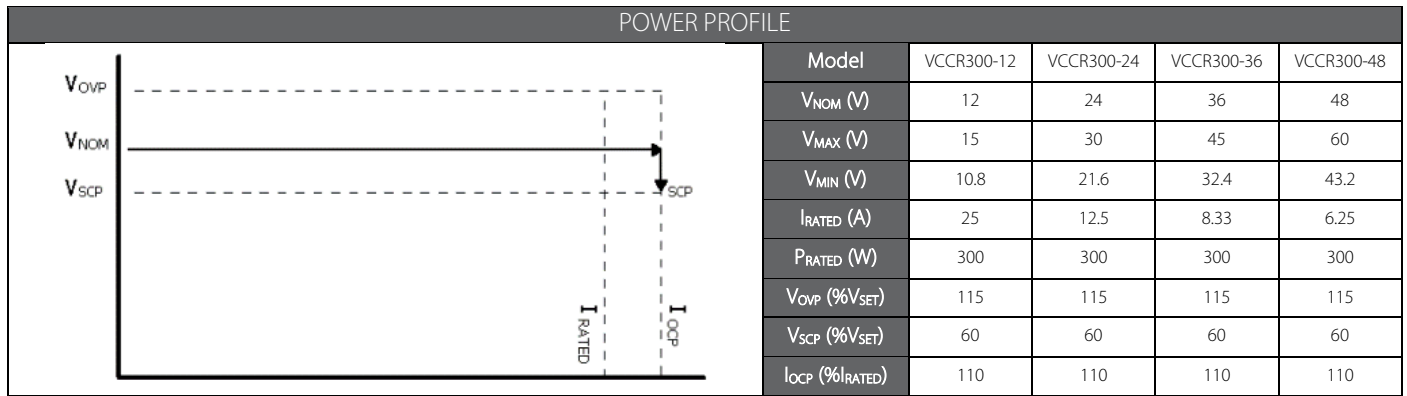

Output Over Voltage Protection (OVP)

In the event of an output fault, the unit is protected against excessive output voltages. If the output voltage exceeds the V_{OVP} threshold, the output will be disabled, and the unit will attempt to restart at a minimum of 500 millisecond intervals. The V_{OVP} level is not fixed and tracks the voltage setpoint.

Output Over Current & Short Circuit Protection (OCP & SCP)

The over current threshold is typically set at 110% of the rated current and has a constant current, straight line characteristic that reduces the output voltage as the load resistance decreases. If the output voltage falls below the short circuit voltage threshold (V_{SCP}) the unit enters short circuit protection mode. In SCP mode, the output shuts down completely for a minimum of 500 milliseconds then attempts to restart. This process repeats until the overload condition is removed, at which point normal operation resumes.

Output Reverse Current Protection (RCP)

The output uses synchronous rectification to achieve high efficiency. Typically synchronously rectified outputs can both source and sink current. The VCCR300 series outputs have internal protection to prevent any reverse current flowing into the unit.

Start-up & Shut Down

The outputs are designed to have a controlled start-up with a nominal rise time of approximately 35ms (10% to 90%) under any load. Start-up into pre-biased loads will not discharge any external capacitance or cause any damage to the unit.

At shutdown, the outputs enter a high impedance state. Where no external load is present it may take some time for the voltage to decay. When driving inductive loads, care must be taken to limit the voltage at the output terminals to prevent damage to the unit.

External capacitance

The outputs can support a large external capacitance as detailed in the table shown. The capacitances specified ensure reliable start-up with rated load applied. Larger capacitances can be applied for reduced load currents.

V_{OUT}	12	24	36	48
C_{EXT_MAX} (mF)	3	1.41	0.66	0.54

Output Ripple and Noise

The ripple and noise figures stated in the datasheet are defined based on a standard measuring method. To obtain the same results the same test setup must be used, and care must be taken to eliminate any parasitic noise pickup. The diagram below shows details of the setup and sources of noise pickup.

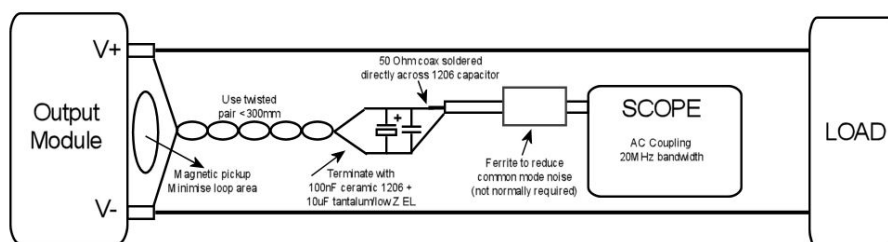

The output ripple frequency can vary from 200kHz to 300kHz but is typically 260kHz. Under light load conditions (<3W) the unit may enter burst mode, the ripple frequency will reduce significantly and the peak-to-peak amplitude may increase as specified in the datasheet.

Output Transient Response

The VCCR300 series uses the latest current mode control algorithms to achieve a fast (<1mS) and stable response to dynamic loading. Where large dynamic loading and tight voltage deviation specification are required, additional low impedance external capacitance should be placed at the load.

User Controls

Output voltage adjustment (VOUT_ADJ)

The output voltage can be adjusted by connecting VOUT_ADJ to COM (J2 pin 1 to pin 2) through an external resistor according to the formula below,

$$V_{SET} = (0.9 + 0.35 * R_{EXT} / 50k) * V_{NOM}, 0k\Omega < R_{EXT} < 50k\Omega$$

If J2 pin 1 is left open, the output voltage will return to the nominal setting.

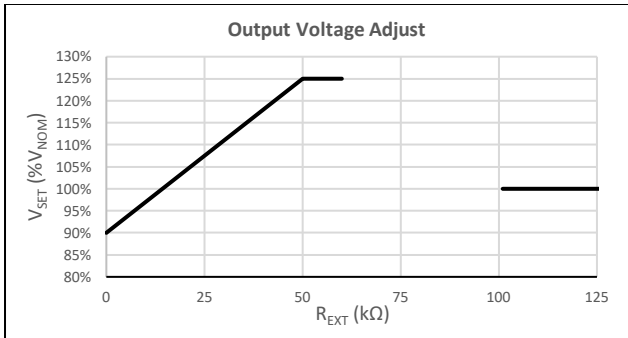

Output voltage OK (DC_OK)

The DC_OK signal is an open drain output that indicates when the output voltage is above 90% of the voltage setting.

DC_OK state	Condition
<20Ω to COM	V _{OUT} > 0.9*V _{SET}
>1MΩ to COM	V _{OUT} < 0.9*V _{SET}

Warning signal (WARN)

The WARN signal is an open drain output that will indicate any of the following warnings,

- OTP_WARN (Output rectifier temp > 100°C)
- OCP_WARN (Output current > 105% of rated current)
- HOLD_WARN (Minimum of 5mS holdup remaining)

WARN state	Condition
<20Ω to SCOM	(OTP_WARN or OCP_WARN or HOLD_WARN)
>1MΩ to SCOM	No Warnings

Output current measurement (IOUT)

The IOUT control outputs a measure of the load current to the user according to the following formula,

$$I_{OUT} = 5V * I_{OUT} / I_{RATED}$$

The output impedance is 1kΩ.

Share Mode (DROOP)

When paralleling multiple units, share mode should be enabled by connecting DROOP to IOUT (J2 pin 3 to pin 4).

In share mode, the output voltage of each unit has an artificial voltage drop (V_{DROOP}) added that reduces the output voltage as the current increases. The adjustment is symmetrical so that at 0% load the voltage is typically V_{NOM}+V_{DROOP}, at 50% load it is V_{NOM} and at 100% load it is V_{NOM}-V_{DROOP}. Up to +/-2.5% of the output voltage can be added to the load regulation according to the following formula,

$$V_{DROOP} (\pm\%V_{NOM}) = 2.5 * 536k / (R_{EXT} + 536k)$$

$$R_{EXT} = 0 \text{ (Short J2 pin 3 to pin 4) gives a slope of } \pm 2.5\%V_{NOM}$$

Adding slope to the load regulation enables the paralleled units to share load current equally between them and increase system reliability.

See [DOC-APN-006](#) on the vox power website for more details on droop mode current sharing.

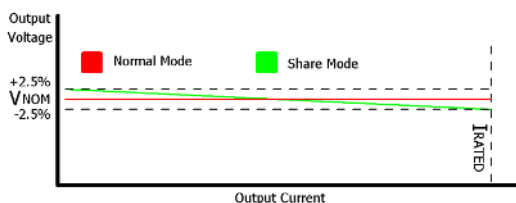

Common (SCOM)

This is the return reference for the following secondary side controls.

VOUT_ADJ, DC_OK, WARN, IOUT & DROOP

It is internally connected to the output voltage negative terminal (J3 pin 2). Care should be taken not to connect externally to the positive output voltage.

Shutdown & Under-Voltage (SD_UV)

The SD_UV control can be used to shut down the output or adjust the undervoltage lockout level on the input voltage.

SD_UV	Function	UVLO
Open	ON	30V
R _{EXT} to V _{IN_NEG} (0.2MΩ < R _{EXT} < 1MΩ)	ON	30V to 100V See function below
R _{EXT} to V _{IN_NEG} (R _{EXT} < 0.1MΩ)	OFF	Not defined

$$V_{UV} = 100V - (70V * (R_{EXT} - 0.2M\Omega) / 0.8M\Omega), 0.2M\Omega < R_{EXT} < 1M\Omega$$

The reference voltage for the SD_UV signal is V_{IN_NEG} which is available on J2 Pin 10 for convenience.

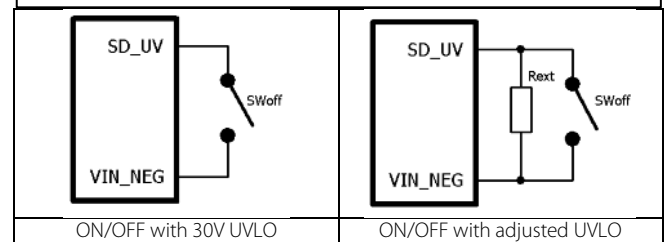
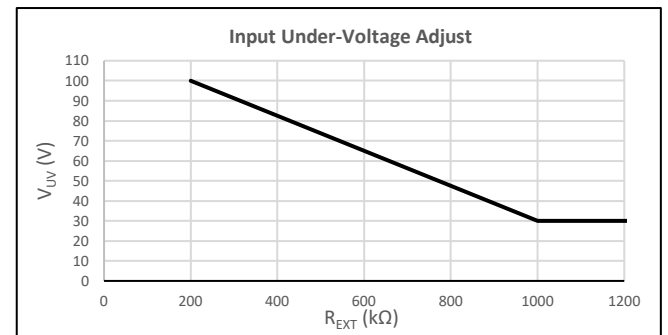

Maximum ratings

Secondary Control (SCOM to)	Min	Max	Unit
VOUT_ADJ	-0.3	3.3	V
DC_OK & WARN	-0.3	12	V
IOUT & DROOP	-0.3	6	V
Primary Control (V _{IN_NEG} to)	Min	Max	Unit
SD_UV	-0.3	50	V

Note: 10mA maximum current into any control pin

LED indicator

The LED indicator has the following function,

Colour	DC_OK	WARN
OFF	0	0
RED	0	1
GREEN	1	0
ORANGE	1	1

Factory Programmable Functions

The following parameters can be pre-programmed in the factory,

1. Input Under Voltage Lockout
2. Output DC voltage level
3. Output over current limit
4. WARN signal functionality

Consult Vox Power for details.

Efficiency Performance

The efficiency of the VCCR300 product is dependent on parameters such as input voltage, output power and on the model. The plots below show typical efficiencies of a VCCR300 product for the standard output voltages. The plots cover the full load and input voltage range.

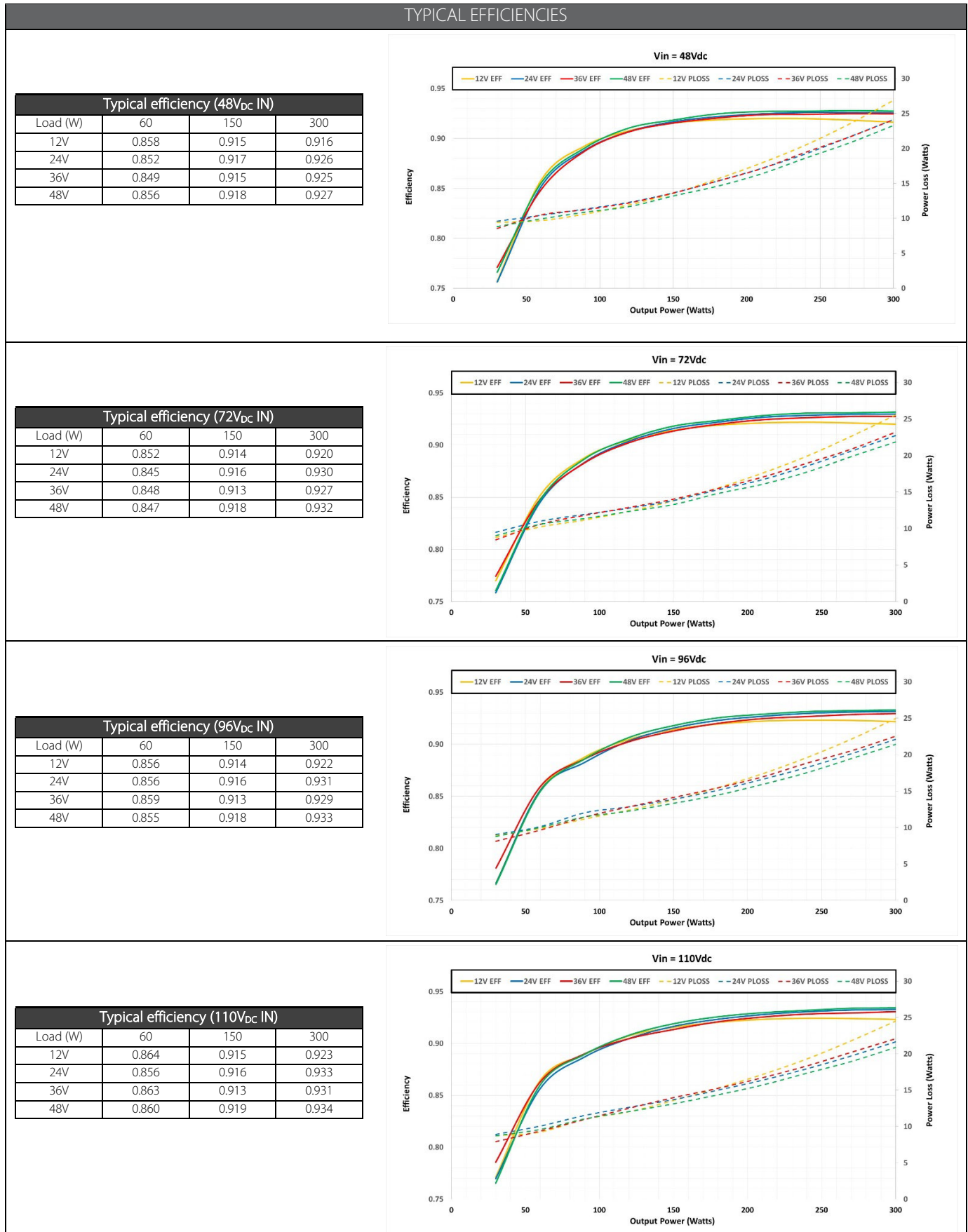

Mechanical Dimensions and Mounting

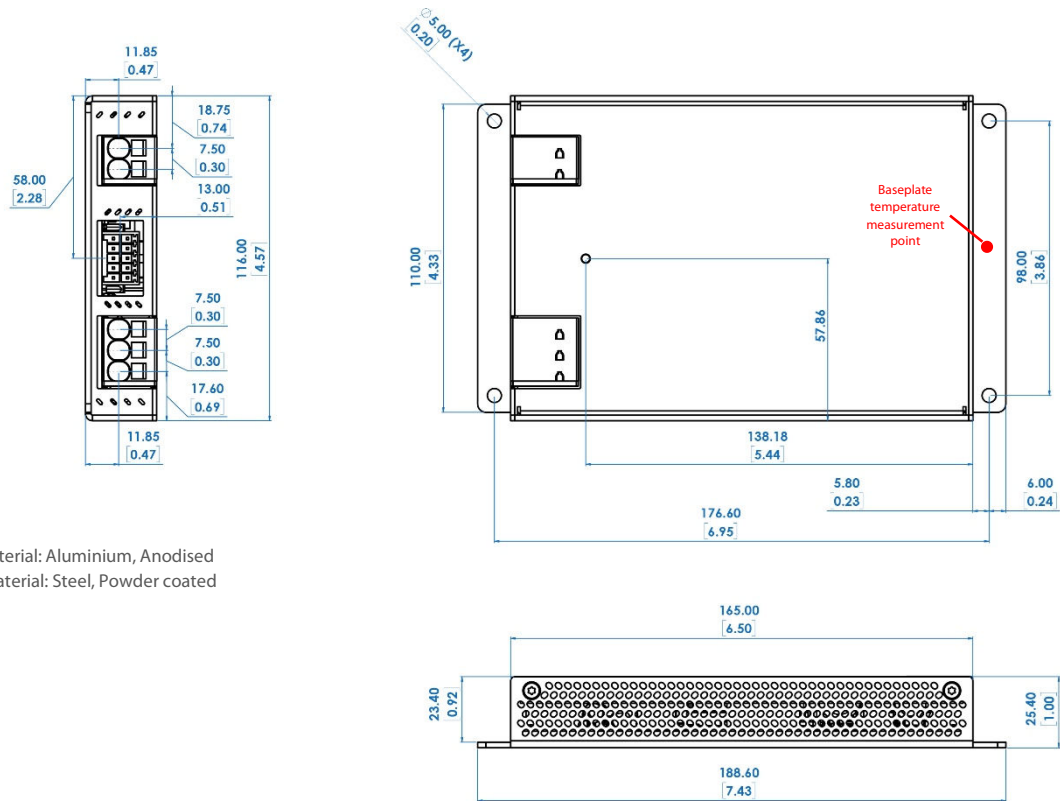

Chassis base material: Aluminium, Anodised
Chassis cover material: Steel, Powder coated

CONNECTORS AND PINOUT

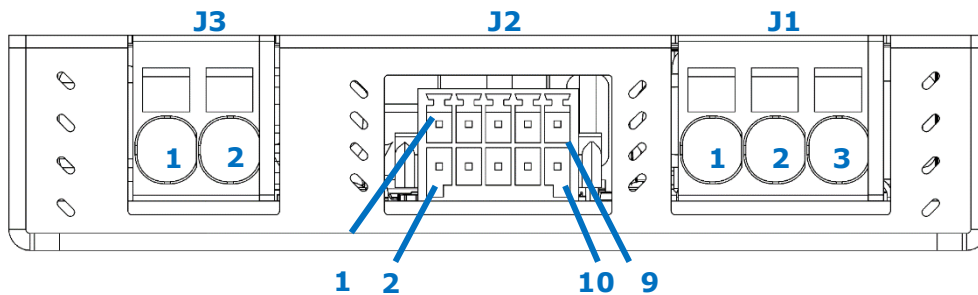

J3 - DC output voltage	
Pin	Function
1	Positive
2	Negative

J2 - User Controls	
Pin	Function
1	Output voltage adjust (VOUT_ADJ)- Connect to SCOM through a resistor
2	Secondary common (SCOM) - Internally connect to J3 Pin 2
3	Droop input (DROOP) - Connect to IOUT through a resistor
4	Output current measurement (IOUT)
5	WARN - Open drain output. Active Low.
6	DC_OK - Open drain output. Active Low.
7	BLANK
8	BLANK
9	Shut Down & Under voltage adjust (SD_UV) Connect to V _{IN,NEG} through resistor for under voltage adjust. Close switch V _{IN,NEG} to SD_UV for shutdown.
10	Primary negative (V _{IN,NEG}) - Internally connect to J1 Pin 1

J1 - DC input voltage	
Pin	Function
1	Negative
2	Positive
3	Protective Earth

Note 1: Ensure adequate conductor sizes are used. Refer to connector datasheets if necessary.

Safety

The VCCR300 unit has been designed to comply with the Low Voltage Directive DIR 2014/35/EU (LVD), the EMC Directive DIR 2014/30/EU and DIR 2011/65/EU regarding the restriction of certain hazardous substances and is CE marked to show its compliance. When correctly installed (per the installation instructions in this manual) in a limited access environment the VCCR300 comply with the requirements of IEC/EN/UL/CSA 62368-1:2018 and EN50155:2021.

- The power supply should not be operated close to combustible materials or atmosphere.
- Care should be taken to ensure liquid, or metal shavings do not enter the power supply as this can cause a fire hazard.
- The power supply does not contain any user serviceable parts and should be returned to Vox Power for repair.

WARNING!

- Series connected units with combined voltages exceeding 60 volts are not considered SELV. Paralleled and/or series units with combined energy ratings greater than 240 VA may cause energy hazards. The equipment manufacturer must provide additional and adequate protection to service and technical personnel.
- Always remove the power before handling the unit. During operation, the external surface of the unit can become hot. Leave to stand for 10 minutes to allow the unit to cool down before handling the unit.
- Dangerous voltages are present within the power supply even when the supply voltage has been removed.

SAFETY & INSULATION SPECIFICATIONS				
Barrier	Rating	Voltage withstand ⁽³⁾ (V _{DC})	Creepage distance ⁽²⁾ (mm)	Insulation resistance ⁽¹⁾ (MΩ)
Input to Output	Reinforced	5400	5	>300
Input to Chassis	Basic	3400	3.5	>300
Output to Chassis	Basic	2000	3.5	>300

1. Insulation resistance tested at 500V_{DC}
2. Material group IIIb, Pollution degree PD2 & Overvoltage category OV3 as defined in EN50124-1:2017
3. Tested in production
4. Insulation coordination complies with EN50124-1:2017 & EN62368-1:2018

Withstand Voltage Test

The VCCR300 units are designed to withstand the test voltages listed below using the test circuit shown.

Test Circuit							
Voltage	Ramp	Dwell	I _{MIN}	I _{MAX}	Test Type	SW1	SW2
5400V _{DC} ⁽¹⁾	10s	60s	0	5mA	Input to Output.	A	A
3400V _{DC}	10s	60s	0	5mA	Input to Chassis.	B	B
2000V _{DC}	10s	60s	0	5mA	Output to Chassis.	A	B

Note 1. Balancing resistors may be required to prevent overstress of the input or output to chassis barriers during this test.

INSTALLATION SPECIFICATIONS			
Parameter	Details	Parameter	Details
Equipment class (EN62368-1:2018)	I	Flammability Rating (EN62368-1:2018)	94V-2
Overvoltage category (EN50124-1:2017)	OV3	Material Group	IIIb
Pollution degree	PD2	Ingress protection rating	IP30

AGENCY APPROVALS		
Standard	Details	File
IEC 62368-1:2018	3 rd Edition. Audio/video, information and communication technology equipment - Part 1: Safety requirements	
UL 62368-1:2019	3 rd Edition. Audio/video, information and communication technology equipment - Part 1: Safety requirements	UL: E316486
CSA-C22.2 No. 62368-1:2019	3 rd Edition. Audio/video, information and communication technology equipment - Part 1: Safety requirements	
CE	LVD 2014/35/EU, EMC 2014/30/EU, RoHS 2 2011/65/EU	
UKCA	Safety SI 2016 No 1101, EMC SI 2016 No 1091, RoHS SI 2012 No. 3032	

Approval certificates available at www.vox-power.com

To support compliance of the final system design with the EMC directive 2014/30/EU, the VCCR300 PSU has been designed and tested to the following standards.

ELECTROMAGNETIC COMPLIANCE – EMISSIONS				
Phenomenon	Port	Reference Standards	Test Details	
Radiated emissions, electric field	Enclosure	EN50155:2021 cl.13.4.9 EN50121-3-2:2016 cl.7 EN61000-6-4 tbl.1 EN55032/CISPR16-1-1	30MHz to 1GHz. EN50032 Class B compliant. Exceeds the requirements of EN50121-3-2:2016	
Conducted emissions	Battery power supply	EN50155:2021 cl.13.4.9 EN50121-3-2:2016 cl.7 tbl.2.1 EN55032/EN55016-2-1	150kHz to 30MHz EN50032 Class B compliant. Exceeds the requirements of EN50121-3-2:2016	
ELECTROMAGNETIC COMPLIANCE – IMMUNITY				
Phenomenon	Port	Reference Standards	Test Details	Performance ⁽¹⁾
Electrostatic discharge	Enclosure	EN50155:2021 cl.13.4.9 EN50121-3-2:2016 cl.8 tbl.5.3 IEC61000-4-2	Test level 3: ±8kV air, ±6kV contact	Criteria A
Radiated RF EM field, AM	Enclosure	EN50155:2021 cl.13.4.9 EN50121-3-2:2016 cl.8 tbl.5.1 IEC61000-4-3	20V/m, 80MHz-800MHz, sine wave, AM 80%, 1kHz	Criteria A
Radiated RF EM field	Enclosure	EN55035:2017 cl.5 tbl.1.3 EN50155:2021 cl.13.4.9 EN50121-3-2:2016 cl.8 tbl.5.2 IEC61000-4-3	Test levels as per EN50121-3-2 table 5, item 5.2 & EN55035:2017 Table 1, item 1.3	Criteria A
Electrical Fast Transients/burst	Battery power supply	EN50155:2021 cl.13.4.9 EN50121-3-2:2016 cl.8 tbl.3.2 IEC61000-4-4	Test Level 3: ±2kV, 5/50nS, 5kHz, Direct coupling	Criteria A
Electrical Fast Transients/burst	Control	EN50155:2021 cl.13.4.9 EN50121-3-2:2016 cl.8 tbl.4.2 IEC61000-4-4	Test Level 4: ±2kV, 5/50nS, 5kHz, Capacitive clamp coupling	Criteria A
Surge	Battery power supply	EN50155:2021 cl.13.4.9 EN50121-3-2:2016 cl.8 tbl.3.3 IEC61000-4-5	1.2/50uS, 42Ω, 0.5uF, ±1kV L-L & ±2kV L-E 1.2/50uS, 12Ω, 9uF, ±1kV L-L & ±2kV L-E	Criteria A
Conducted disturbances induced by RF field	Battery power supply	EN50155:2021 cl.13.4.9 EN50121-3-2:2016 cl.8 tbl.3.1 IEC61000-4-6	Test Level 3: 10V, 0.15 to 80MHz, sine wave, AM 80%, 1kHz	Criteria A
Conducted disturbances induced by RF field	Control	EN50155:2021 cl.13.4.9 EN50121-3-2:2016 cl.8 tbl.4.1 IEC61000-4-6	Test Level 3: 10V, 0.15 to 80MHz, sine wave, AM 80%, 1kHz	Criteria A
Temporary supply overvoltage	Battery power supply	EN50155:2021 cl.13.4.3.3 IEC61000-4-29	110V to 168V for 100ms & 1s	Criteria A
Temporary supply undervoltage	Battery power supply	EN50155:2021 cl.13.4.3.4 IEC61000-4-29	48V to 28.8V for 100ms	Criteria A
Interruptions of supply voltage	Battery power supply	EN50155:2021 cl.13.4.3.5 IEC61000-4-29 ²⁾	Interruption for 10ms at 300W load. EN50155:2021 Class S2 Interruption for >10ms at 300W load Interruption for 20ms at 180W load. EN50155:2021 Class S3 Interruption for >20ms at 180W load	Criteria A Criteria C Criteria A Criteria C
Supply change-over	Battery power supply	EN50155:2021 cl.13.4.3.6 IEC61000-4-29	48V to 28.8V for 100ms. Class C1 48V to open circuit for 30ms. Class C2	Criteria A Criteria B
Notes:	<ol style="list-style-type: none"> 1. Performance criteria are defined in EN50155:2021 cl.4.3 2. Tested at minimum nominal input voltage. (48V) 			

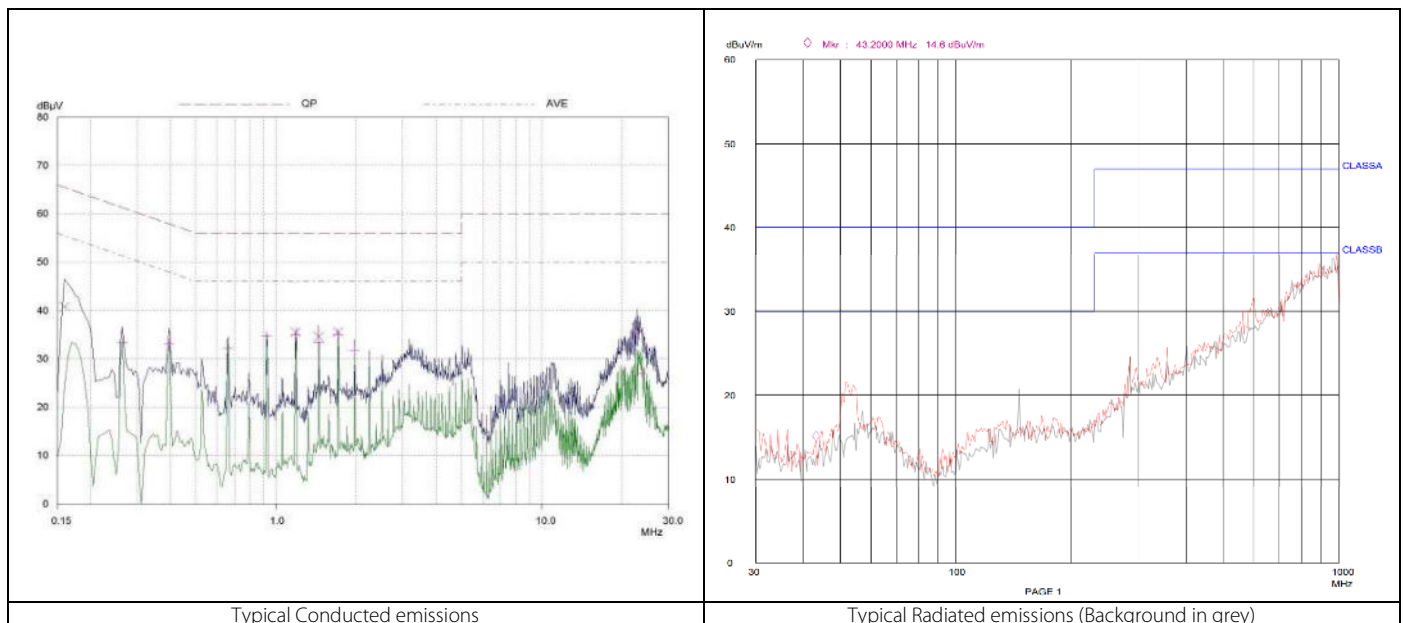

For radiated and conducted emissions, compliance of the final system relies on proper installation of the PSU component.

Reliability

The VCCR300 series has been designed to be extremely rugged and reliable. All opto-couplers have been eliminated from the design, only a minimum number of high reliability electrolytic capacitors are used, and the internal assembly is covered with a protective coating. The series has undergone extensive testing, including HALT and Environmental testing. Reliability data is collected on an ongoing basis. Please contact Vox Power or your distributor for the most up to date reliability data.

The reliability data quoted in the datasheets are the calculated *failures per million hours* (FPMH) using the Telcordia SR-332, issue 3 standard. The procedure defined in SR-332 allows several different techniques to be used for calculating MTBF and when evaluating competing MTBF figures it is important that only the same techniques are compared.

The quoted VCCR300 reliability figures use Method I Case 3, Ground, Fixed, controlled which specifies an ambient temperature of 30°C and an upper confidence level of 90%. It is also assumed that the product is operated at 100% duty cycle, has an input voltage of 48V_{DC}, an output power of 300W and that the baseplate temperature is the same as the ambient temperature.

The variation in FPMH is shown in the graph and table below.

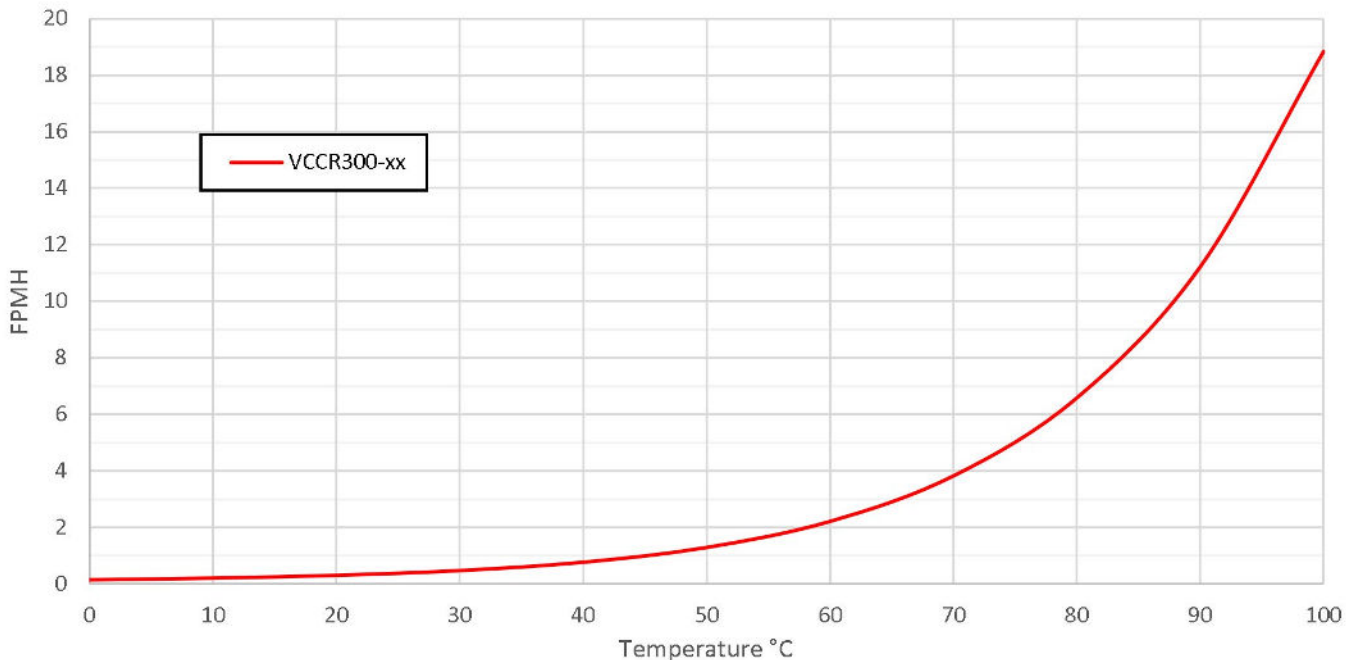

Ambient Temperature	0	10	20	30	40	50	60	70	80	90	100
Failure Rate (FPMH)	0.15114	0.21221	0.31115	0.47958	0.77443	1.29647	2.21893	3.82789	6.58677	11.2219	18.8425
MTBF (Hrs)	6616084	4712275	3213856	2085150	1291270	771320	450666	261240	151819	89111	53071

Installing your VCCR300 Product

The VCCR300 power supply is designed to be used as part of an end-system in a restricted environment and therefore should only be accessible to qualified and trained personnel. Persons attempting to install a unit must have the necessary knowledge and training before doing so. Incorrect installation may cause damage to the power supply and may affect the warranty.

DO NOT use parts if any part of the product exhibits any kind of physical damage.
DO NOT connect any power before the installation is complete.

Once installation has been completed, operation of the unit should be verified. Note that the case must be maintained below the maximum temperature specified in the datasheet.

Please contact Vox Power or your distributor for assistance in installing your power supply. Never assume, always ask.

Mounting the unit

The unit should be securely fixed to the end system using the four Ø5mm mounting holes provided. It is recommended to leave at least 5mm clearance around all sides of the unit.

Fitting a thermal interface material between the chassis base and the mounting surface will improve system cooling and extend the life of the product.

The mounting orientation of the VCCR300 will not impact on correct product operation.

Connecting units in series

VCCR300 units of the same type can be series connected to achieve higher output voltages. Below is an illustration of how-to series connect two units to give 600W of output power.

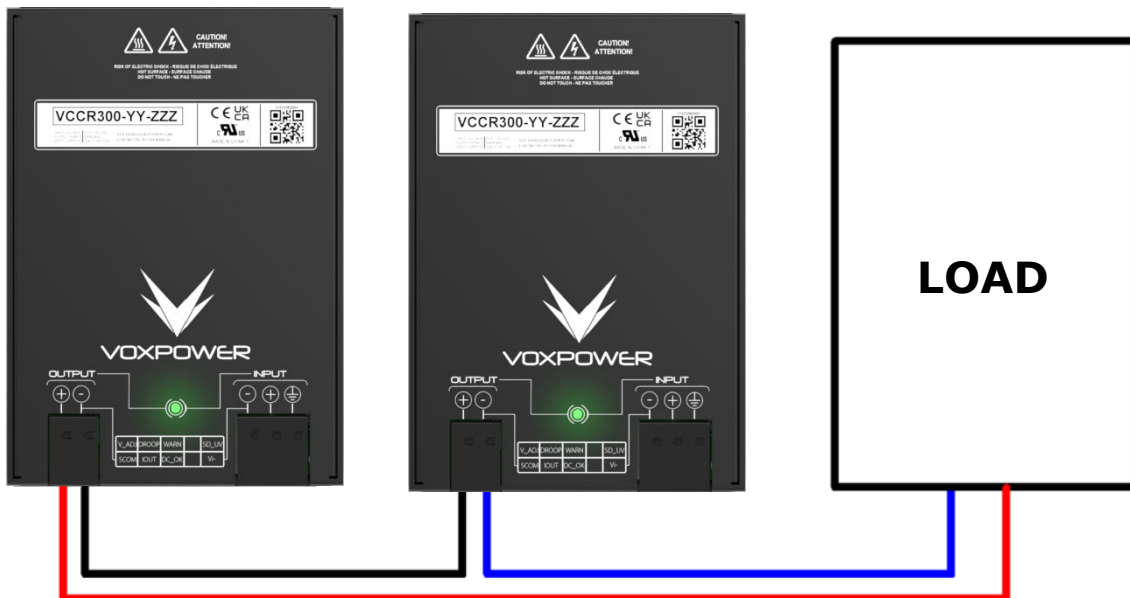

WARNING!

- Energy and voltage hazards may arise when individual units are series connected. When safe energy and voltage levels are exceeded ensure that an appropriate warning label is affixed to the power supply in a manner that service personnel will always notice it. See the Safety section for more details.

Isolation to Ground

Care must be taken not to exceed the output isolation to chassis ground when series connecting units. Each output is rated for 3100 Volts DC maximum between each output terminal and chassis ground. Exceeding this voltage may damage the unit.

SELV Precautions

Where series combinations of units exceed 60V, the output can no longer be considered SELV (Safety Extra Low Voltage) and hence the final equipment manufacturer must provide suitable protection for both users and service personnel.

Ripple

When outputs are series connected, the output ripple will increase and may contain frequencies in the audio spectrum.

Connecting units in parallel

VCCR300 units of the same type can be paralleled in any number to achieve higher output currents. To parallel the outputs simply connect all the positive power cables together and all the negative power cables together. No other external circuitry is necessary. For best performance and increased reliability, it is recommended to enable share mode on each unit (See "User Controls: Share Mode (Droop)" section for details). The accuracy of current sharing is highly dependent on external cable resistance. To minimise errors, it is important to have equal cable lengths from each output terminal to the common connection point for both positive and negative cables.

Below is an illustration of optimised parallel connection of two units to give 600W of output power.

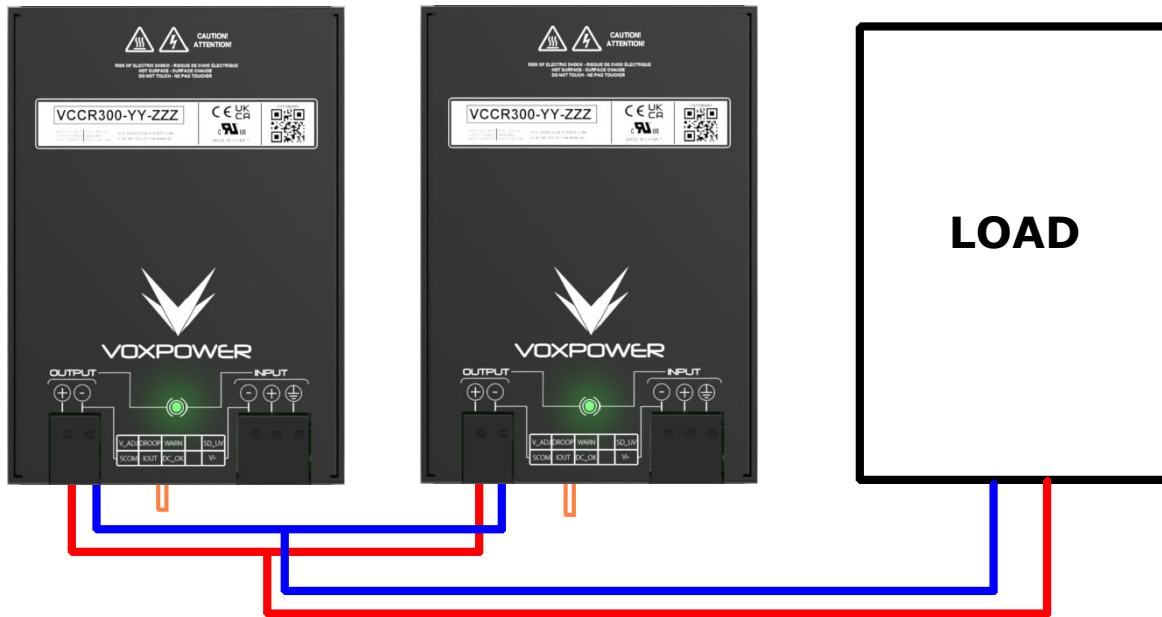

WARNING!

- Energy and voltage hazards may arise when individual units are paralleled. When safe energy and voltage levels are exceeded ensure that an appropriate warning label is affixed to the power supply in a manner that service personnel will always notice it. See the Safety section for more details.

Ripple

When outputs are paralleled, the output ripple may contain frequencies in the audio spectrum.