

# NEVO+600 Series

## USER MANUAL



600W

Powerful

5" x 3" x 1.61"

Small

600g

Light

600 Watts in the palm of your hand

The NEVO+600 series user manual has been prepared by the Vox Power design team to assist qualified engineers in correctly implementing the product and to achieve the best reliability and performance possible.

All specifications are believed to be correct at time of publishing. Vox Power Ltd reserves the right to make changes to any of its products and to change or improve any part of the specification, electrical or mechanical design or manufacturing process without notice. Vox Power Ltd does not assume any liability arising out of the use or application of any of its products and of any information to the maximum extent permitted by law. No license, express or implied, by estoppel or otherwise, to any intellectual property rights is granted by this document or by any products of Vox Power Ltd. VOX POWER LTD DISCLAIMS ALL WARRANTIES AND REPRESENTATIONS OF ANY KIND WHETHER EXPRESS OR IMPLIED, INCLUDING, BUT NOT LIMITED TO, IMPLIED WARRANTIES OF SUITABILITY, FITNESS FOR PURPOSE, MERCHANTABILITY AND NON-INFRINGEMENT.

Please consult your local distributor or Vox Power directly to ensure that you have the latest revision before using the product and refer to the latest relevant user manual for further information relating to the use of the product. Vox Power Ltd products are not intended for use in connection with life support systems, human implantations, nuclear facilities or systems, aircraft, spacecraft, military or naval missile, ground support or control equipment used for the purpose of guidance navigation or direction of any aircraft, spacecraft or military or naval missile or any other application where product failure could lead to loss of life or catastrophic property damage. The user will hold Vox Power Ltd harmless from any loss, cost or damage resulting from its breach of these provisions.

### NEVO+600 series overview

The NEVO+600 switch mode power supply series offers truly unrivalled power density, providing 600 W at 25 W/in<sup>3</sup> in a 5" x 3"x 1U package. It is the ultimate power solution for system designers as they address the pressing demands for more power within less space. Providing multiple isolated outputs, the series carry full IEC60601 (NEVO+600M/ML only) and IEC60950 & IEC62368 (NEVO+600S/SL) safety approvals. The basic system consists of an input module together with up to four fully isolated output modules. Single output modules have advanced remote voltage and current programming functionality as standard. While dual output modules allow for up to eight fully isolated outputs. The input module delivers up to 600 W of output power and has 4 slots, each capable of separately delivering up to 150 W. A 5 V, 1A medically isolated bias supply together with an AC\_OK signal and a global inhibit signal that can disable all outputs simultaneously, comes as standard on all models. Output modules are available in a range of output voltages and currents to suit all applications. Single output modules with voltage ranges from 1.5V to 60V, currents up to 25A and paralleling and series capability can result in a voltage range up to 240V and a maximum current of up to 100 Amps from a single NEVO+600 configuration. Dual output modules have a voltage ranges from 1.5V to 15V and currents up to 5A with series capability. By selecting the correct output modules, a custom power solution can be configured in a few minutes. This instantly available custom solution offers industry leading power density, total system efficiencies of up to 89% and suits all types of applications including industrial, medical, aerospace, military and telecoms.

## Contents

NEVO+600 series overview .....	1
Contents .....	2
Part numbers and ordering information .....	3
Installation Notes .....	4
Theory of operation .....	11
Input module operation .....	12
Signalling .....	15
Single Output module operation .....	17
Advanced Single Output module features .....	20
Series Connected outputs .....	23
Paralleled outputs .....	24
Dual Output module operation .....	28
Audible noise .....	30
Mechanical dimensions and mounting .....	31
Connectors .....	32
Configuring your power supply .....	33
Safety .....	35
EMC compliance .....	37
Reliability .....	37

## Part numbers and ordering information

INPUT MODULES	
Model	Details
NEVO+600S	600 Watt input stage with ITE Approvals (UL/IEC60950 Edition 2 & UL/IEC62368 Edition 2)
NEVO+600SL	450 Watt low audible noise input stage with ITE Approvals (UL/IEC60950 Edition 2 & UL/IEC62368 Edition 2)
NEVO+600M	600 Watt input stage with Medical Approvals (UL/IEC60601 Edition 3 + UL/IEC60601-1-2 Edition 4 EMC)
NEVO+600ML	450 Watt low audible noise input stage with Medical Approvals (UL/IEC60601 Edition 3 + UL/IEC60601-1-2 Edition 4 EMC)

OUTPUT MODULES								
Model	Nominal Voltage	Rated Current	Rated Power	Adjustment Range	Load Regulation	Line Regulation	OVP	Slots
0	Unused slots							1
1	5V	25A	125W	1.5V-7.5V	±50mV	±0.1%Vnom	9V	1
2	12V	15A	150W	4.5V-15V	±100mV	±0.1%Vnom	18V	1
3	24V	7.5A	150W	9V-30V	±150mV	±0.1%Vnom	36V	1
4	48V	3.75A	150W	18V-58V	±300mV	±0.1%Vnom	66V	1
A2	12V	25A	300W	4.5V-15V	±100mV	±0.1%Vnom	18V	2
A3	24V	15A	300W	9V-30V	±150mV	±0.1%Vnom	36V	2
5	12V Dual OP	5A	75W x 2	3.3V-15V Each Ch	±50mV	±0.1%Vnom	22V	1
8	24V Dual OP	3.125A	75W x 2	24V Each Ch	±100mV	±0.1%Vnom	30V	1

### IMPORTANT NOTE

NEVO+ SERIES A3 MODULES CAN ONLY BE USED WITH NEVO+600 CHASSIS WITH DATE CODES FROM 2048 ONWARDS.  
EG. 2048C080000 CAN USE A3 MODULE, 2047C089999 CANNOT USE A2 MODULE.

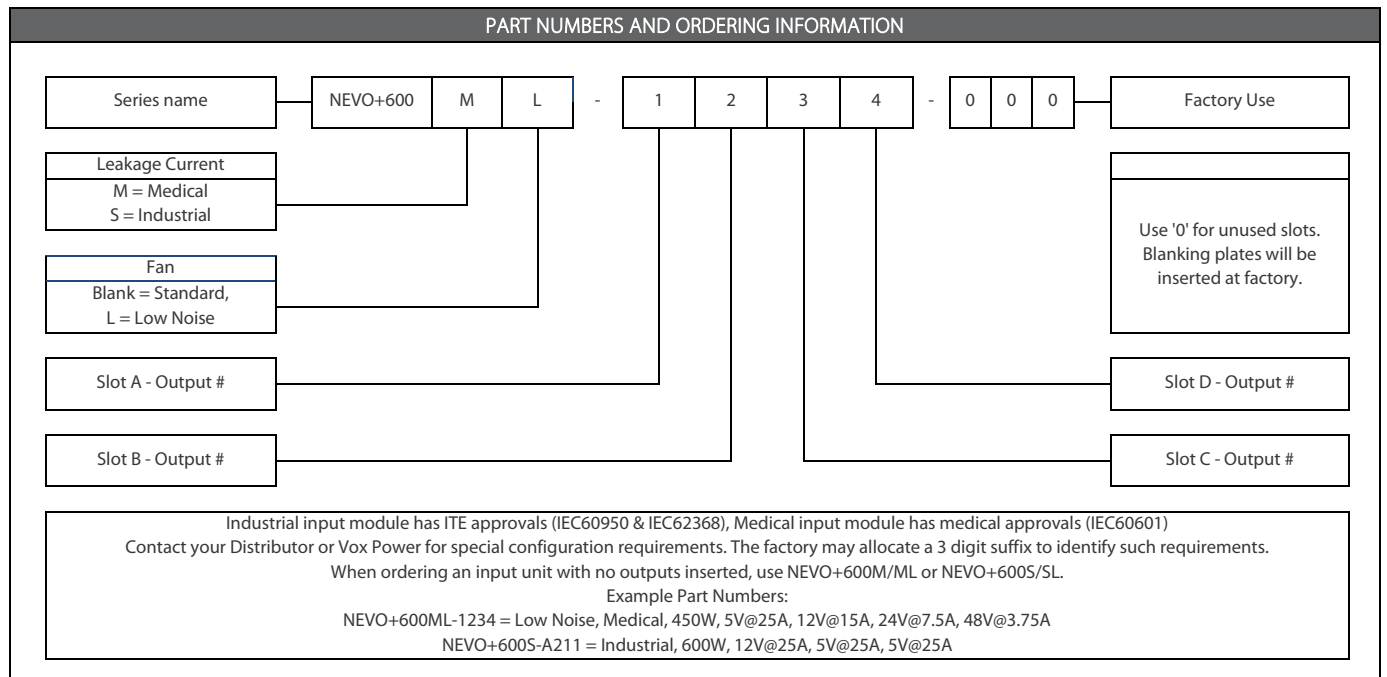



## Installation Notes

The instructions in this manual and all warning labels on the product must be followed carefully.



### PRODUCT USE

Vox Power Ltd products are not intended for use in connection with life support systems, human implantations, nuclear facilities or systems, aircraft, spacecraft, military or naval missile, ground support or control equipment used for the purpose of guidance navigation or direction of any aircraft, spacecraft or military or naval missile or any other application where product failure could lead to loss of life or catastrophic property damage. The user will hold Vox Power Ltd harmless from any loss, cost or damage resulting from its breach of these provisions.

### INSTALLATION

This power supply has been designed in accordance with the relevant safety requirements of IEC/EN/UL/CSA 62368-1, IEC/EN/UL/CSA 60950-1, IEC/EN/UL/CSA 60601-1, Low voltage Directive LVD 2014/35/EU and EMC directive EMC 2014/30/EU.

The power supply is considered a component power supply and must be installed within an end equipment by qualified personnel. The end equipment must provide a controlled environment which restricts access to any unauthorised personnel. Equipment and system manufacturers must protect operators and service personnel against unintentional contact with hazardous terminals.

### HAZARDS

	<p><b>Risk of electric shock</b> This power supply contains dangerous voltages. Appropriate protections must be implemented.</p>		<p><b>Hot Surface</b> The external surfaces of this power supply may become hot during and after use. Appropriate protections must be implemented.</p>
--	--	--	--

If series and/or parallel combinations of outputs exceed safe voltage and/or energy levels, the final equipment manufacturer must provide appropriate protection for both users and service personnel.

### SYSTEM LABELING

A label that is clearly visible to service personnel must be placed on the final equipment, which warns that surfaces of the power supply may be hot and should not be touched when the product is operating.

Where the incoming wiring earth is intended for connection as the main protective earth conductor and where the terminals for such a connection is not supplied on a component or subassembly, the user shall add an appropriate label displaying a protective earth symbol in accordance with IEC60417-5019 (2006-08) directly adjacent to the terminal.

All labels should be durable and legible and should withstand the 15 second rub test as per UL60950-1 section 1.7.15.

### FUSING

This power supply has internal single pole fusing in the L (Live) line. **Fuses are not replaceable.**

For Medical (60601-1) installations, the end application should provide an appropriately rated external fuse in the Neutral line.

**DC operation is not covered by safety approvals.** Contact Vox Power for details.

### DE-RATINGS

Ambient Temperature	The input module power must be de-rated by 2.5%/°C above 50°C up to a maximum ambient temperature of 70°C.
Input Voltage	The input module power must be de-rated by 0.713%/V <sub>RMS</sub> below 120 V <sub>RMS</sub> (e.g. 600W @ 120 V <sub>RMS</sub> , 450W @ 85 V <sub>RMS</sub> )

Remember to take the appropriate de-rating into consideration before specifying any power supply for an application. If in any doubt, please contact Vox Power directly or your local Vox Power representative.

### SERVICING

This power supply contains no user serviceable parts. Repairs must be carried out by authorised personnel only. Contact Vox Power Ltd for further information.

### COOLING

For proper cooling of the power supply, the air intake and outlet must not be impeded. Allow 50 mm clearance at both ends and position cabling appropriately. Avoid excessive back pressure in the general system or when using ducting to navigate hot air out of the system.

### END OF LIFE DISPOSAL

This power supply may contain components that require special disposal. At end of life, ensure that the unit is disposed of according to local regulations.

### OTHER

- To prolong the life of the unit, use in a dust free environment.
- If units are damaged during transit, contact your sales agent or Vox Power and DO NOT apply power to the unit.
- Always use adequately sized cables and ensure good crimp connections. Use cable supports to minimise stress on connectors.
- Avoid excessive shock or vibration.

### GENERAL INSTALLATION PARAMETERS

• Equipment class	1	• Installation category	II
• Pollution degree	2	• Material group	IIIb (Indoor use only)
• Flammability rating	94V-2	• IP rating	IP10
• RoHS compliance	2011/65/EU & 2015/863/EU		



## Installationshinweise

Die Anweisungen in dieser Anleitung und alle Warnhinweise auf dem Produkt sind sorgfältig zu befolgen.



### PRODUKTVERWENDUNG



Produkte von Vox Power Ltd sind nicht vorgesehen für den Gebrauch in Zusammenhang mit Lebenserhaltungssystemen, menschliche Implantaten, Nuklearanlagen oder -systemen, Flugzeugen, Raumfahrzeugen, militärischen Lenkflugkörpern, boden- oder steuerungstechnischem Gerät für den Einsatz zum Zwecke der Navigation oder Lenkung von Flugzeugen, Raumfahrzeugen oder Lenkflugkörpern oder sonstigen Anwendungen, bei denen ein Produktversagen zum Tode oder zu katastrophalen Schäden führen kann. Der Anwender wird Vox Power Ltd von jeglichen Verlusten, Kosten oder Schäden schadlos halten, die auf die Verletzung dieser Bestimmungen zurückzuführen sind.

### INSTALLATION

Diese Netzteil entspricht in Auslegung und Konstruktion den einschlägigen Sicherheitsanforderungen gemäß DIN EN IEC 62368-1, DIN EN IEC 60950-1, DIN EN IEC 60601-1, Niederspannungsrichtlinie 2014/35/EU und EMV-Richtlinie 2014/30/EU.

Das Netzteil wird als Einbaunetzteil betrachtet und muss daher von einer Elektrofachkraft in ein Endgerät eingebaut werden. Das Endgerät muss eine geschützte Umgebung/Umhäusung aufweisen, die den Zugang für unbefugte Personen beschränkt. Geräte- und Anlagenhersteller müssen Bedien- und Wartungspersonal vor unbeabsichtigtem Kontakt der gefährlichen Anschlüsse schützen.

### GEFAHREN

 <p><b>Gefahr durch elektrischen Schlag</b> In diesem Netzteil können gefährliche Spannungen anliegen. Es sind geeignete Schutzmaßnahmen vorzusehen.</p>	 <p><b>Heiße Fläche</b> Die äußeren Flächen dieses Netzteils können beim und nach dem Gebrauch heiß werden. Es sind geeignete Schutzmaßnahmen vorzusehen.</p>
---	--

Überschreiten in Reihe oder parallel geschaltete Ausgangskombinationen sichere Spannungs- und/oder Energiepegel, hat der Endgerätehersteller für den angemessenen Schutz für Anwender und Wartungspersonal zu sorgen.

### SYSTEMKENNZEICHNUNG

Das Endgerät ist mit einem gut für das Wartungspersonal sichtbaren Aufkleber (o. ä.) zu versehen, der davor warnt, dass die Netzteiloberflächen im Betrieb heiß sein könnten und nicht berührt werden sollten.

Ist die eingehende Erdleitung für den Anschluss als Hauptschutzleiter vorgesehen und es sind auf Baugruppen- oder Bauteilebene keine Anschlüsse für einen solchen Anschluss vorhanden, hat der Anwender in unmittelbarer Nähe des Anschlusses einen geeigneten Aufkleber mit dem Symbol Schutzterde gemäß IEC 60417-5019 (2006-08) anzubringen.

Alle Aufkleber müssen dauerhaft und lesbar sein und die 15-Sekunden-Reibprüfung gemäß UL60950-1 Abschnitt 1.7.15 bestehen.

### SICHERUNG

Dieses Netzteil ist mit einer internen einpoligen Sicherung in der stromführenden Leitung (L) abgesichert. **Sicherungen sind nicht auswechselbar.**

Für Medizinprodukte nach DIN EN 60601-1 sollte die Endanwendung über eine ausreichend bemessene externe Sicherung im Neutralleiter abgesichert sein.

**Der Betrieb an Gleichspannung ist nicht Bestandteil der Sicherheitszulassungen.** Bei Fragen bitte an Vox Power wenden.

### DERATING (Reduzierung von Maximalwerten)

Umgebungstemperatur	Die Leistung des Eingangsmoduls ist oberhalb 50 °C um 2,5 % je Grad Celsius zu reduzieren. Dies gilt bis zur Höchstumgebungstemperatur 70 °C.
Eingangsspannung	Die Leistung des Eingangsmoduls ist unterhalb 120 V <sub>eff</sub> um 0,713 % je V <sub>eff</sub> zu reduzieren (Beispiel: 600 W bei 120 V <sub>eff</sub> = 450 W bei 85 V <sub>eff</sub> )

Berücksichtigen bei der Bemessung und Spezifikation jedes Netzteils stets ein entsprechendes Derating. Bei Fragen bitte direkt an Vox Power oder an Ihre zuständige Vertretung für Vox Power wenden.

### INSTANDHALTUNG

Reparaturen sind ausschließlich durch befugte Personen durchzuführen. Bei Informationsbedarf bitte an Vox Power Ltd wenden.

### KÜHLUNG

Um eine ausreichende Kühlung des Netzteils zu gewährleisten, sind Lufteinlass und -auslass freizuhalten. Es ist ein Mindestabstand von 50 mm zu Wänden und Gegenständen einzuhalten. Achten Sie auf eine entsprechende Kabelführung. Vermeiden Sie hohe Staudrücke in der Gesamtanlage oder bei Verwendung von Abluftkanälen zur Fortleitung der Warmluft.

### ENTSORGUNG

Dieses Netzteil kann Komponenten enthalten, die gesondert entsorgt werden müssen. Bei der Entsorgung des Gerätes sind die jeweils gültigen Vorschriften zu beachten.

### SONSTIGES

- Zur Optimierung der Lebensdauer sollte das Gerät in einer staubfreien Umgebung betrieben werden.
- Bei Transportschäden das GERÄT NICHT ANSCHLIESSEN ODER IN BETRIEB NEHMEN. Wenden Sie sich bitte an Ihre Handelsvertretung oder an Vox Power.
- Verwenden Sie stets Kabel mit ausreichenden Querschnitten und achten Sie auf gute Crimpanschlüsse. Verwenden Sie Kabelhalter, um die Steckverbinder möglichst wenig zu beanspruchen.
- Vermeiden Sie übermäßige Stoß- oder Schwingbeanspruchungen.

## ALLGEMEINE INSTALLATIONSPARAMETER

- |                      |                          |                          |                         |
|----------------------|--------------------------|--------------------------|-------------------------|
| • Geräteklasse       | I                        | • Überspannungskategorie | II                      |
| • Verschmutzungsgrad | 2                        | • Isolierstoffgruppe     | IIIb (nur Innenbereich) |
| • Entflammbarkeit    | UL 94V-2                 | • Schutzart              | IP10                    |
| • RoHS-Konformität   | 2011/65/EU & 2015/863/EU |                          |                         |



**Instrucciones de instalación**  
Las instrucciones de este manual y las etiquetas de advertencia del producto se deben seguir estrictamente.



## USO DEL PRODUCTO

Los productos de Vox Power Ltd no están destinados a su conexión a sistemas de soporte vital, implantaciones en personas, instalaciones o sistemas nucleares, aviones, vehículos espaciales, misiles militares o navales, equipamiento de soporte o control terrestre utilizado para guiar la navegación o la dirección de aviones, vehículos espaciales o misiles militares o navales o cualquier otra aplicación en las que una avería del producto pudiera provocar la pérdida de vidas o daños catastróficos en propiedades. El usuario eximirá a Vox Power Ltd de cualquier pérdida, coste o daño resultante del incumplimiento de estas condiciones.

## INSTALACIÓN

Esta fuente de alimentación se ha diseñado en conformidad con los requisitos de seguridad correspondientes de IEC/EN/UL/CSA 62368-1, IEC/EN/UL/CSA 60950-1, IEC/EN/UL/CSA 60601-1, Directiva de Baja Tensión LVD 2014/35/EU y Directiva EMC 2014/30/EU.

La fuente de alimentación se considera un componente que debe ser instalado en un equipo final por personal cualificado. El equipo final debe proporcionar un entorno controlado que limite el acceso al personal no autorizado. Los fabricantes de los equipos y los sistemas deben proteger a los operarios y al personal de mantenimiento frente al contacto accidental con terminales peligrosos.

## PELIGROS

	<b>Riesgo de descarga eléctrica</b> Esta fuente de alimentación contiene tensiones peligrosas. Se deben aplicar las protecciones apropiadas.		<b>Superficies calientes</b> Las superficies externas de esta fuente de alimentación se pueden calentar durante y después de su uso. Se deben aplicar las protecciones apropiadas.
--	--	--	--

Si las combinaciones en serie y/o paralelo de las salidas superan los niveles de tensión y/o energía de seguridad, el fabricante del equipo final debe proporcionar la protección apropiada a los usuarios y al personal de mantenimiento.

## ETIQUETADO DEL SISTEMA

Se debe colocar una etiqueta sobre el equipo final de manera que sea claramente visible para el personal de mantenimiento. Esta etiqueta advertirá que las superficies de la fuente de alimentación pueden estar calientes y no se deberían tocar cuando el producto está en funcionamiento.

Cuando la entrada de la toma de tierra esté destinada a la conexión como conductor a tierra de protección principal y los terminales para esta conexión no hayan sido suministrados en un componente o subsistema, el usuario añadirá una etiqueta apropiada que indique un símbolo de toma de tierra de protección en conformidad con IEC60417-5019 (2006-08) y la colocará al lado del terminal.

Todas las etiquetas deben ser resistentes y legibles, y deben superar la prueba de rasgado durante 15 segundos de UL60950-1 sección 1.7.15.

## FUSIBLES

Esta fuente de alimentación tiene fusibles internos de un solo polo en la línea con corriente L (Live). **Los fusibles no son sustituibles.**

En instalaciones médicas (60601-1), la aplicación final debe proporcionar un fusible externo de las especificaciones apropiadas en la línea del Neutro.

**El funcionamiento con CC no queda cubierto por las homologaciones de seguridad.** Contacte con Vox Power para más información.

## REAJUSTE DE ESPECIFICACIONES

Temperatura ambiente	La potencia del módulo de entrada se debe reducir un 2,5%/°C por encima de 50°C hasta una temperatura ambiente máxima de 70°C.
Tensión de entrada	La potencia del módulo de entrada se debe reducir un 0,713%/V <sub>RMS</sub> por debajo de 120 V <sub>RMS</sub> (p.ej., 600W a 120 V <sub>RMS</sub> , 450W a 85 V <sub>RMS</sub> ).

Recuerde que es necesario reajustar las especificaciones antes de escoger una fuente de alimentación para una determinada aplicación. Si tiene alguna duda, contacte con Vox Power directamente o a través de un representante de la empresa.

## REPARACIONES

Esta fuente de alimentación no contiene piezas reparables. Las reparaciones deben ser efectuadas únicamente por personal autorizado. Contacte con Vox Power Ltd para más información.

## REFRIGERACIÓN

Para que la refrigeración de la fuente de alimentación sea correcta no se deben obstruir la entrada y la salida de aire. Deje 50 mm de margen en ambos extremos e instale el cableado de manera apropiada. No ejerza una presión excesiva sobre el sistema en general ni utilice conductos para extraer aire caliente del sistema.

## ELIMINACIÓN AL FINAL DE LA VIDA ÚTIL

Esta fuente de alimentación puede contener componentes que requieren un tratamiento especial al desecharlos. Asegúrese de cumplir la normativa correspondiente cuando finalice la vida útil de la unidad.

#### OTROS

- Para prolongar la vida útil de la unidad utilícela en un entorno libre de polvo.
- Si las unidades sufren daños durante su traslado, contacte con su representante comercial o con Vox Power y NO alimente la unidad.
- Use siempre los cables del diámetro adecuado y comprueba que conexiones tienen el engarce correcto. Utilice soporte para el cable para minimizar el esfuerzo en los conectores.
- Evite fuertes choques o vibraciones.

#### PARÁMETROS GENERALES DE INSTALACIÓN

- |                           |                          |  |      |
|---------------------------|--------------------------|--|------|
| • Clase del equipo        | 1                        | • Categoría de instalación                           | II   |
| • Grado de contaminación  | 2                        | • Grupo de material<br>(para uso solo en interiores) | IIIb |
| • Grado de inflamabilidad | 94V-2                    | • Grado de IP  | IP10 |
| • Conformidad con RoHS    | 2011/65/EU & 2015/863/EU |  |      |



**Remarques relatives à l'installation**  
Les instructions de ce manuel et les étiquettes d'avertissement présentes sur le produit doivent être respectées scrupuleusement.



#### UTILISATION DU PRODUIT

Les produits Vox Power Ltd ne sont pas destinés à être utilisés dans des systèmes de survie, des implants chirurgicaux, des installations ou systèmes nucléaires, des avions, des engins spatiaux, des missiles militaires ou navals, des équipements de soutien au sol ou de commande utilisés à des fins de guidage, de navigation ou d'orientation d'avion, d'engin spatial ou de missile militaire ou naval, ni dans toute autre application dans laquelle une défaillance du produit pourrait entraîner une perte de vie humaine ou des dommages matériels catastrophiques. L'utilisateur ne saurait tenir responsable Vox Power Ltd de toute perte financière, coût ou dommage résultant du non-respect de ces termes.

#### INSTALLATION

Cette alimentation est conçue conformément aux exigences de sécurité applicables des normes IEC/EN/UL/CSA 62368-1, IEC/EN/UL/CSA 60950-1, IEC/EN/UL/CSA 60601-1, de la directive basse tension LVD 2014/35/EU et de la directive CEM 2014/30/EU.

L'alimentation est considérée comme un composant de puissance, et doit être installée dans l'équipement final par du personnel qualifié. L'équipement final doit fournir un environnement contrôlé qui restreint l'accès à toute personne non autorisée. Les fabricants d'équipements et de systèmes doivent protéger les opérateurs et le personnel de service contre tout contact involontaire avec les bornes présentant un danger.

#### DANGERS

	<b>Risque de choc électrique</b> Cette alimentation contient des tensions dangereuses. Des protections appropriées doivent être mises en place.		<b>Surfaces chaudes</b> Les surfaces externes de cette alimentation peuvent devenir très chaudes pendant et après l'utilisation. Des protections appropriées doivent être mises en place.
--	---	--	---

Si la combinaison en série et/ou en parallèle de sorties multiples amène à dépasser les niveaux de tension et/ou d'énergie sûrs, le fabricant de l'équipement final doit fournir une protection appropriée aux utilisateurs et au personnel de maintenance.

#### ÉTIQUETAGE DU SYSTÈME

Une étiquette bien visible du personnel de maintenance doit être apposée sur l'équipement final, pour avertir que certaines surfaces de l'alimentation peuvent être chaudes et ne doivent pas être touchées lorsque l'équipement fonctionne.

Lorsque le conducteur de terre du câblage entrant est destiné à être connecté en tant que conducteur principal de protection et que la borne de connexion ne se trouve pas sur un composant ou un sous-ensemble, l'utilisateur doit apposer une étiquette appropriée affichant un symbole de protection conformément à la norme CEI60417-5019 (2006-08) à proximité directe de la borne.

Toutes les étiquettes doivent être durables et lisibles, et résister au test de frottement de 15 secondes conformément à la section 1.7.15 de la norme UL60950-1.

#### FUSIBLE DE PROTECTION

Cette alimentation dispose d'un fusible unipolaire interne dans la ligne L (Phase). **Les fusibles ne sont pas remplaçables**

Pour les installations médicales (60601-1), l'application finale doit fournir un fusible externe de valeur appropriée sur la ligne Neutre.

**Le fonctionnement en courant continu n'est pas couvert par les homologations de sécurité.** Contactez Vox Power pour plus de détails.

#### DÉCLASSEMENT

Température ambiante	La puissance du module d'entrée doit être déclassée de 2,5 %/°C au-delà de 50°C jusqu'à une température ambiante maximale de 70°C.
Tension d'entrée	La puissance du module d'entrée doit être déclassée de 0,713%/V <sub>eff</sub> en dessous de 120 V <sub>eff</sub> (Ex : 600 W à 120 V <sub>eff</sub> équivaut à 450 W à 85 V <sub>eff</sub> )

N'oubliez pas de tenir compte du déclassement approprié avant de spécifier une alimentation pour une application. En cas de doute, veuillez contacter directement Vox Power ou votre représentant local Vox Power.

## MAINTENANCE

Cette alimentation ne contient aucun composant réparable par l'utilisateur. Les réparations ne doivent être effectuées que par du personnel autorisé. Contactez Vox Power Ltd pour plus d'informations.

## REFROIDISSEMENT

Pour un bon refroidissement de l'alimentation électrique, l'entrée et la sortie d'air ne doivent pas être obstruées. Laissez un espace de 50 mm aux deux extrémités et positionnez le câblage de manière appropriée. Évitez toute contre-pression excessive dans le système général et dans les éventuels conduits servant à évacuer l'air chaud du système.

## ÉLIMINATION EN FIN DE VIE

Cette alimentation peut contenir des composants nécessitant une procédure d'élimination particulière. En fin de vie, assurez-vous que l'appareil est éliminé conformément aux réglementations locales.

## AUTRE

- Pour prolonger la durée de vie de l'appareil, utilisez-le dans un environnement non-poussièreux.
- Si l'unité a été endommagée durant son transport, contactez votre représentant commercial ou Vox Power, et NE mettez PAS l'unité sous tension.
- Utilisez toujours des câbles de diamètre adéquat et assurez-vous que les connexions soient bien serties et bien serrées. Utilisez des supports de câbles pour minimiser les contraintes sur les connecteurs.
- Évitez les chocs et les vibrations excessives.

## PARAMÈTRES D'INSTALLATION GÉNÉRAUX

- |                           |                          |                            |                             |
|---------------------------|--------------------------|----------------------------|-----------------------------|
| • Classe d'équipement     | 1                        | • Catégorie d'installation | II                          |
| • Degré de pollution      | 2                        | • Groupe de matériaux      | IIIb (intérieur uniquement) |
| • Indice d'inflammabilité | 94V-2                    | • Indice IP                | IP10                        |
| • Conformité RoHS         | 2011/65/EU & 2015/863/EU |                            |                             |



**Note per l'installazione**  
Seguire scrupolosamente le istruzioni del presente manuale e le indicazioni di tutte le etichette di avvertenza presenti sul prodotto.





## USO DEL PRODOTTO

I prodotti Vox Power Ltd non sono previsti per l'uso in relazione a sistemi di supporto delle funzioni vitali, impianti su esseri umani, impianti o centrali nucleari, aeroplani, veicoli spaziali, missili navali o per usi militari, apparecchiature di controllo o supporto di sistemi terrestri impiegati per la guida o l'orientamento di qualsiasi aerodina, missili navali oppure per usi militari o veicoli spaziali o qualunque altra applicazione in cui un guasto al prodotto potrebbe comportare la perdita di vite o danni catastrofici alle cose. L'utilizzatore manleverà e terrà indenne Vox Power Ltd da qualsiasi perdita, costo o danno risultante dalla violazione di queste disposizioni.

## INSTALLAZIONE

Questo alimentatore è stato progettato in conformità ai requisiti relativi alla sicurezza specificati nelle seguenti norme e direttive: IEC/EN/UL/CSA 62368-1, IEC/EN/UL/CSA 60950-1, IEC/EN/UL/CSA 60601-1, Direttiva 2014/35/UE "bassa tensione" e Direttiva 2014/30/UE relativa alla compatibilità elettromagnetica. L'alimentatore è considerato un componente di un'apparecchiatura finale e deve essere installato nella stessa da personale qualificato. Tale apparecchiatura deve assicurare un ambiente controllato che limiti l'accesso a personale non autorizzato. I produttori di apparecchiature e sistemi devono proteggere gli operatori e il personale di manutenzione contro il contatto non intenzionale con terminali pericolosi.

## RISCHI

	<b>Rischio di folgorazione</b> In questo alimentatore sono presenti alte tensioni. Attuare misure di protezione appropriate.		<b>Superfici ad alta temperatura</b> Le superfici esterne di questo alimentatore possono raggiungere temperature elevate durante e dopo l'uso. Attuare misure di protezione appropriate.
---	--	---	--

Se combinazioni in serie e/o in parallelo delle uscite superano livelli sicuri di tensione e/o energia, il produttore dell'apparecchiatura finale deve garantire una protezione adatta sia per gli utilizzatori che per il personale di manutenzione.

## ETICHETTATURA DELL'IMPIANTO

Sull'apparecchiatura finale deve essere apposta un'etichetta, chiaramente visibile dal personale di manutenzione, avvisante che le superfici dell'alimentatore possono raggiungere temperature elevate e non devono essere toccate mentre il prodotto è in funzione.

Nel caso in cui il cavo di terra in ingresso sia concepito per la connessione come principale conduttore di protezione al potenziale di terra e i terminali per tale connessione non siano forniti su un componente o un gruppo secondario, direttamente accanto al terminale l'utilizzatore deve aggiungere un'appropriata etichetta che mostri un simbolo di terra di protezione in conformità alla norma IEC60417-5019 (2006-08).

Tutte le etichette devono essere durevoli e leggibili e devono superare la prova di strofinamento di 15 secondi a norma UL60950-1 sezione 1.7.15.

## FUSIBILI

Questo alimentatore è dotato di uno o più fusibili unipolari interni inseriti nella linea sotto tensione. **I fusibili non possono essere sostituiti.**

Nel caso di installazioni mediche (60601-1), l'applicazione finale deve prevedere un fusibile esterno di portata adatta inserito nella linea del neutro.

**Il funzionamento in CC non ricade nell'ambito delle approvazioni di sicurezza.** Per maggiori informazioni contattare Vox Power.

## DERATING

Temperatura ambiente	La potenza del modulo d'ingresso deve ridursi del 2,5%/°C oltre 50 °C fino a una temperatura ambiente max di 70 °C.
----------------------	---



Tensão d'ingresso	La potenza del modulo d'ingresso deve ridursi dello 0,713%/V <sub>eff</sub> sotto 120 V <sub>eff</sub> (per es., 600 W a 120 V <sub>eff</sub> , 450 W a 85 V <sub>eff</sub> )
-------------------	---

Prendere in considerazione l'appropriato derating prima di specificare un eventuale alimentatore per un'applicazione. In caso di dubbi, contattare direttamente Vox Power o il rappresentante locale Vox Power.

#### RIPARAZIONI

Questo alimentatore non contiene parti su cui l'utilizzatore possa intervenire. Eventuali riparazioni devono essere eseguite esclusivamente da personale autorizzato. Per ulteriori informazioni contattare Vox Power Ltd.

#### RAFFREDDAMENTO

Per garantire l'appropriato raffreddamento dell'alimentatore, le aperture di ingresso e uscita dell'aria non devono essere ostruite. Assicurare uno spazio libero di 50 mm a entrambe le estremità e posizionare i cavi appropriatamente. Evitare una contropressione eccessiva nell'impianto generale o quando si utilizzano condotti per fare fluire l'aria calda fuori dell'impianto.

#### SMALTIMENTO A FINE VITA

Questo alimentatore potrebbe contenere componenti che richiedono uno smaltimento speciale. Al termine della sua durata, accertarsi che venga smaltito in conformità alle norme di legge.

#### ALTRE INDICAZIONI

- Per prolungare la durata del dispositivo, impiegarlo in un ambiente privo di polvere.
- Se un dispositivo viene danneggiato durante il trasporto, contattare l'agente di vendita locale o Vox Power e NON accenderlo.
- Usare sempre cavi di sezione adeguata e accertarsi che le connessioni siano salde. Usare pressacavo per ridurre al minimo le sollecitazioni sui connettori.
- Evitare urti o vibrazioni di livello eccessivo.

#### PARAMETRI DI INSTALLAZIONE GENERALI

- |                          |                          |                                  |  |
|--------------------------|--------------------------|----------------------------------|--|
| • Classe apparecchiatura | 1                        | • Categoria di installazione     | II                                     |
| • Grado d'inquinamento   | 2                        | • Gruppo materiali locali chiusi | IIIb (solo per l'uso in locali chiusi) |
| • Grado d'infiammabilità | 94V-2                    | • Grado di protezione involucro  | IP10                                   |
| • Conformità RoHS        | 2011/65/EU & 2015/863/EU |                                  |  |



### Informações sobre a instalação

As instruções neste manual e em todas as etiquetas de aviso afixadas no produto devem ser cuidadosamente observadas



#### UTILIZAÇÃO DO PRODUTO

Os produtos da Vox Power Ltd não se destinam a ser utilizados em sistemas de suporte de vida, sistemas para implantação no corpo humano, instalações ou sistemas nucleares, aeronaves, naves espaciais, mísseis militares ou navais, equipamento de suporte no solo ou de controlo para fins de guiamento de navegação ou orientação de aeronaves, naves espaciais ou mísseis militares ou navais ou quaisquer outras aplicações onde a falha do produto possa conduzir à perda de vidas ou a danos materiais catastróficos. O utilizar deve isentar a Vox Power Ltd de quaisquer perdas, custos ou danos decorrentes da violação destas disposições.

#### INSTALAÇÃO

Esta fonte de alimentação foi desenvolvida e construída de acordo com os requisitos de segurança relevantes das normas IEC / EN / UL / CSA 62368-1, IEC / EN / UL / CSA 60950-1, IEC / EN / UL / CSA 60601-1, Directiva de Baixa Tensão 2014/35 / EU e Directiva de Compatibilidade Electromagnética 2014/30 / EU.

A fonte de alimentação é considerada um componente de alimentação e deve ser instalada no equipamento final por pessoal qualificado. O equipamento final deve assegurar um ambiente controlado que restrinja o seu acesso a pessoal não autorizado. Os fabricantes dos equipamentos e sistemas devem proteger os operadores e o pessoal de manutenção contra os contactos não intencionais com terminais perigosos.

#### RISCOS

	<p><b>Risco de choque eléctrico</b> Esta fonte de alimentação contém correntes eléctricas perigosas. Por isso, devem ser utilizadas protecções apropriadas.</p>		<p><b>Superfície quente</b> As superfícies exteriores desta fonte de alimentação podem ficar quentes durante e após a sua utilização. Por isso, devem ser utilizadas protecções apropriadas.</p>
--	---	--	--

Se as montagens em série e/ou paralelo das saídas excederem os níveis de tensão e/ou energia de segurança, o fabricante do equipamento final deve fornecer protecção adequada para os utilizadores e técnicos de manutenção.

#### ETIQUETAS AFIXADAS

Deve ser afixado no equipamento final uma etiqueta claramente visível para o pessoal de manutenção, avisando que as superfícies da fonte de alimentação podem estar quentes e não devem ser tocadas quando o produto estiver em funcionamento.

Quando o condutor de terra de entrada se destinar a ser a ligação principal da terra de protecção e se os terminais para tal conexão não forem fornecidos como componente ou subconjunto único, o utilizador deve afixar uma etiqueta adicional directamente adjacente ao terminal com um símbolo de terra de protecção de acordo com a norma IEC60417-5019 (2006-08) .

Todas as etiquetas devem ser duráveis e legíveis e devem resistir ao ensaio de abrasão durante 15 segundos, conforme a norma UL60950-1, parágrafo 1.7.15.

## FUSÍVEIS

Esta fonte de alimentação está equipada com um fusível monopolar interno no condutor L (Fase). **Os fusíveis não são substituíveis.**

Para aplicações médicas (60601-1), a aplicação final deve conter um fusível externo de capacidade adequada no condutor N (Neutro).

**O funcionamento com corrente DC não está coberto pelas aprovações de segurança.** Contactar a Vox Power para mais informações.

## REDUÇÃO DOS VALORES NOMINAIS

Temperatura Ambiente	A potência do módulo de entrada deve ser reduzida 2,5%/°C acima de 50 °C, até uma temperatura ambiente máxima de 70 °C.
Tensão de Entrada	A potência do módulo de entrada deve ser reduzida 0,713%/V <sub>RMS</sub> abaixo de 120 V <sub>RMS</sub> (por exemplo, 600 W a 120 V <sub>RMS</sub> , 450 W a 85 V <sub>RMS</sub> )

Não esquecer de ter em consideração a redução apropriada, antes de especificar a fonte de alimentação para uma aplicação. Em caso de dúvida, contactar directamente com a Vox Power ou um dos seus Distribuidores.

## SERVIÇO E MANUTENÇÃO

Esta fonte de alimentação não contém peças cuja manutenção possa ser feita pelo utilizador. As reparações devem ser realizadas apenas por pessoal autorizado. Para mais informações, contactar a Vox Power Ltd.

## ARREFECIMENTO

Para o arrefecimento adequado da fonte de alimentação, a entrada e a saída de ar não devem ser obstruídas. Deixe uma folga de 50 mm em ambas as extremidades e posicionar a cablagem de maneira adequada. Evitar uma contrapressão excessiva no sistema geral ou se forem utilizadas condutas para extrair o ar quente do sistema.

## ELIMINAÇÃO FINAL DO PRODUTO

Esta fonte de alimentação pode conter componentes que exijam uma eliminação final especial. No final da sua vida útil, a fonte de alimentação deve ser eliminada de acordo com os regulamentos locais em vigor aplicáveis.

## OUTRAS INSTRUÇÕES

- Para prolongar a vida útil do equipamento, utilizá-lo em ambientes sem poeiras.
- Em caso de danificação do equipamento durante o transporte, contactar o responsável pelo fornecimento ou a Vox Power e NÃO energizar o equipamento.
- Usar sempre cabos de calibre adequado e com boas ligações por cravagem. Suportar devidamente as cablagens, para minimizar as tensões nos conectores.
- Evitar choques ou vibrações excessivas.

## PARÂMETROS GERAIS DA INSTALAÇÃO

- |   |                          |                                |  |
|---|--------------------------|--------------------------------|--|
| • Classe de equipamento                   | I                        | • Categoria da instalação      | II                                     |
| • Nível de poluição                       | 2                        | • Grupo de materiais interior) | IIIb (apenas para utilização interior) |
| • Classe de inflamabilidade               | 94V-2                    | • Classe de protecção          | IP10                                   |
| • Certificação RoHS (materiais perigosos) | 2011/65/EU & 2015/863/EU |                                |  |

## Theory of operation

The diagram below outlines the topology and major internal components of a fully assembled system. Four output slots are provided and can be populated by any combination of *output modules*. The remaining components in the block diagram are housed in the *input module*.

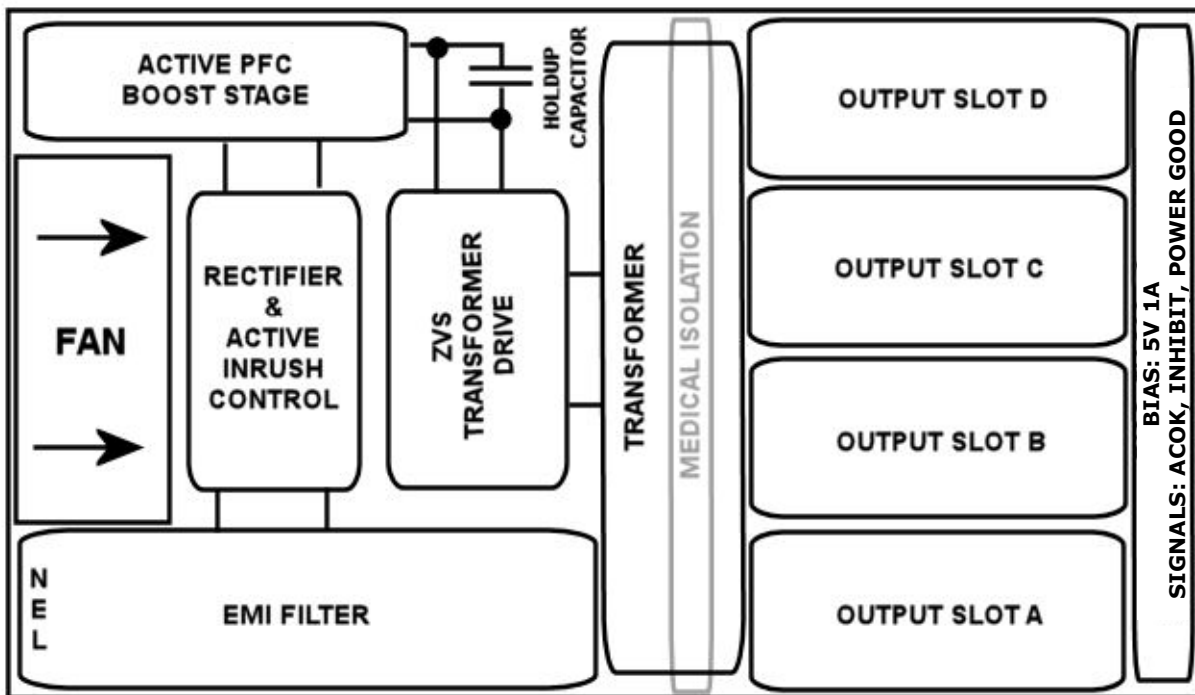

The *input module* is responsible for receiving the AC mains line voltage and converting it to an appropriate DC voltage whilst providing protection from AC line disturbances and preventing excessive EMI emissions and current harmonics. The integrated EMI filter attenuates high frequency current emissions to levels below EN55022 class B. It also provides single pole fusing in the live conductor and protection from line disturbances as outlined in EN61000.

Inrush current is controlled by a resistive element upon initial connection to the AC line. Once the internal capacitances have been charged, the resistive element is bypassed to reduce losses.

Active Power Factor Correction (PFC) is used to ensure an accurate input current waveform with extremely low harmonic content, exceeding the requirements of EN61000. This stage also provides active input current limiting which prevents overloading of the input stage while maintaining high power factor.

The output of the PFC stage charges the hold-up electrolytic capacitors which store enough energy to allow the system to continue operating during minor line disturbances. These are the only electrolytic capacitors in the entire power supply and to further increase system reliability, long life and high temperature capacitors are used.

A highly efficient zero voltage switching circuit is used to drive the medically isolated transformer from the hold-up capacitors. The output modules connect to the transformer secondary and provide safe isolated power to a high performance synchronous rectifier power converter which is controlled using the latest analog control technology to produce superior output performance in an extremely reduced size.

## Input module operation

### Startup & Shut Down

The NEVO+ input modules operate from a universal input voltage range and start automatically upon application of adequate AC mains voltage (>84Vrms). After a short delay, the global 5V bias supply starts and the ACOK signal goes high to indicate that the mains voltage is present and input stage is operating correctly. Once the ACOK signal is high, the output modules turn on and deliver power to the application loads. The power good signals will indicate that the output voltages are within specification. The diagram below shows the normal start up/shut down sequence and gives typical timings.

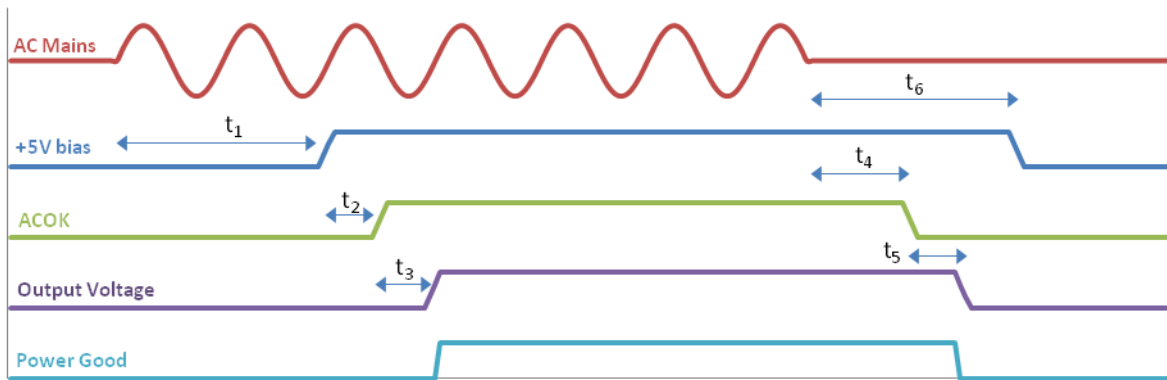

Typical timing values:  $t_1 \phi$  300 ms,  $t_2 \phi$  50 ms,  $t_3 \phi$  25 ms,  $t_4 \phi$  15 ms,  $t_5 =$  5 ms (minimum),  $t_6 \phi$  100 ms

When the AC mains voltage is removed, the internal hold-up capacitors will supply power to the load for typically 20 ms ( $t_4+t_5$ ) at maximum power. The ACOK signal will go low at least 5ms before the output voltages fall below the power good threshold level. This allows the application to prepare for the impending loss of power. The 5V bias supply will remain on for typically 100ms, after the output modules have turned off.

### Hold-up

For short line disturbances (<20ms), the output voltages will not be affected\*. However, the ACOK signal may still go low to warn that there is an impending loss of output power. The ACOK signal will return to the high state once the unit has recovered from the disturbance.

\*Outputs that are adjusted above the hold-up voltage as detailed in their respective datasheets, may experience a dip in voltage but never below the hold-up voltage specified.

### Idle power

The idle power of the NEVO+ PSU is extremely low when compared to similar power supplies.

With the output modules enabled the unit typically only requires 28 W with no output load. To reduce the idle power further the outputs can be disabled using the global inhibit (GINH) pin. With the outputs disabled the unit typically requires less than 21 W.

### Over temperature Protection (OTP)

The input module is protected from excessive temperatures by means of various internal sensors. If temperature thresholds are exceeded the entire unit may latch off, with no ACOK warning. To re-enable the unit the AC mains must be disconnected for approximately 2 minutes.

**Power Derating**

NEVO+600 units must always be operated within its stated operating limits. Equipment manufacturers and other users must take appropriate deratings into account at all times when specifying a unit for the intended application. If in doubt contact your sales representative or Vox Power for assistance.

There are two main deratings for NEVO+600 power supplies, temperature and input line voltage. Temperature deratings apply to both input and output modules, while line deratings apply only to the input module.

For input line voltage, S & M models have an input module power derating of 4.28W per volt below 120V<sub>RMS</sub>. For SL & ML models the derating is 3.21W per volt below 120V<sub>RMS</sub>.

For temperature, the derating for input and output modules is 2.5% per degree Celsius above 50°C. This derating applies to maximum rated input and output power and maximum rated output current. All deratings are cumulative.

These deratings can be calculated using the following conditional equations;

Equation for line derating (S & M Models):

If  $V_{in} < 120$ ,

$$P_{out} = Prated * \text{Line derating factor}$$

$$= Prated * (1 - (4.28/600) * (120 - V_{in}))$$

Otherwise,

$$P_{out} = Prated$$

Equations for temp derating:

If  $temp > 50C$ ,

$$P_{out} = Prated * \text{Temp derating factor}$$

$$= Prated * (1 - (Temp - 50) * 0.025)$$

Otherwise,

$$P_{out} = Prated$$

$$I_{out} = I_{rated} * \text{Temp derating factor}$$

$$= I_{rated} * (1 - (Temp - 50) * 0.025)$$

Otherwise,

$$I_{out} = I_{rated}$$

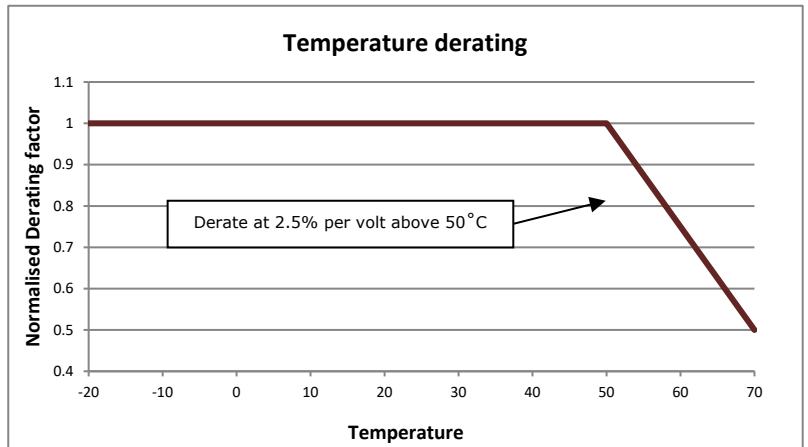
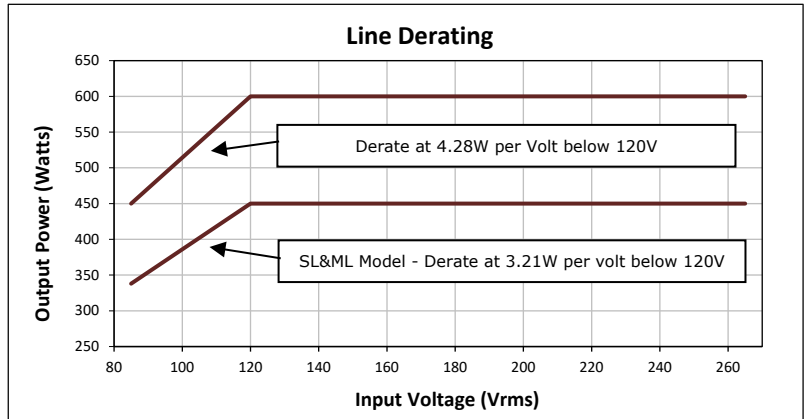

Depending on the application conditions, one or both of the deratings may apply. Where both apply, the derating factors given above can be multiplied together to obtain the total derating factor.

Example: What are the NEVO+600 input and output module deratings at 60°C at 100V line?

Input power rating	=	Prated*line derating factor*Temp derating factor		
Output power rating	=	Prated*Temp derating factor		
Line derating factor	=	$(1 - ((4.28/600) * (120 - V_{in}))$	=	$(1 - (0.007133 * (120 - 100)))$ = 0.85733
Temperature derating factor	=	$(1 - (Temp - 50) * 0.025)$	=	$(1 - (60 - 50) * 0.025)$ = 0.75
Input power rating	=	$600 * 0.85733 * 0.75$	=	385.8W
Output 2 power rating	=	$150 * 0.75$	=	112.5W

## Efficiency

The efficiency of the overall unit is dependent on several parameters such as input voltage, load level and on the combination of output modules. The plots below show typical efficiencies of a NEVO+600 over the full load and line voltage range and fitted with four of each type of output module, equally loaded.

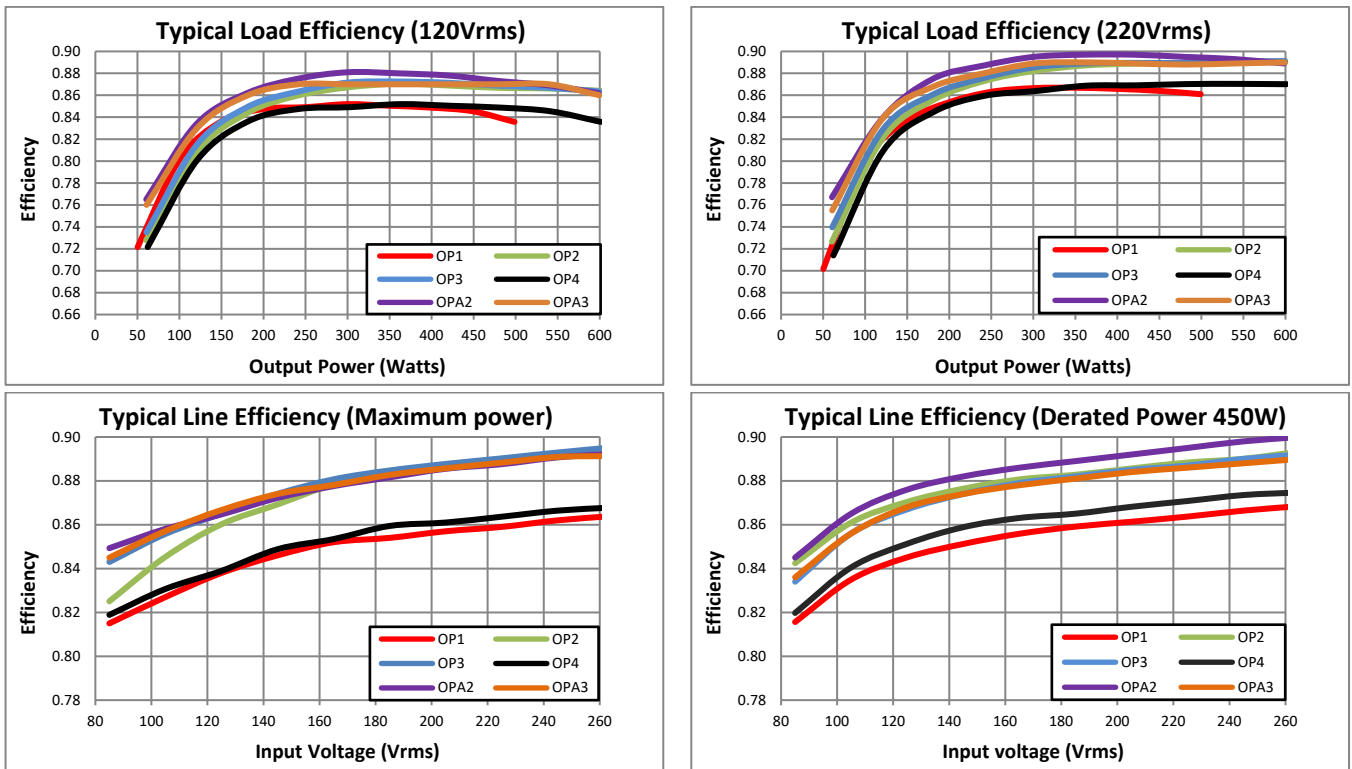

An estimate of the efficiency for any particular system may be obtained from these graphs using the procedure outlined in the example below.

Example: Estimate the efficiency of an NEVO+600-1123, at 160Vrms input and 100W load on each output?

1. Define load efficiencies for each output module at the specified load and 220V.
2. Define change in efficiency from 220Vrms to 160Vrms for each output module.
3. Sum the values from step one and two for each output module.
4. Calculate the average efficiency for the total system.

Step	Details	Slot A	Slot B	Slot C	Slot D
1	$\epsilon_{220}$ (Load chart)	OP1 0.84	OP1 0.84	OP2 0.87	OP3 0.87
2	$\Delta\epsilon_{(220-160)}$ (Line chart)	-0.01	-0.01	-0.01	-0.01
3	$\epsilon_x = \epsilon_{220} + \Delta\epsilon_{(220-160)}$	0.83	0.83	0.86	0.86
4	$\epsilon_{AVE} = (\epsilon_1 + \epsilon_2 + \epsilon_3 + \epsilon_4)/4$	<b>0.845</b>			

## Signalling

To reduce cabling in the end system, all major input and output signals and the global 5V bias supply are wired to a single signals circuit that is accessed through the connector (J2) located at the output side of the chassis as shown in the diagram below.

Pin	Name	Description	
1	PG1	Power Good	Slot A
2	INH1	Inhibit	Slot A
3	PG2	Power Good	Slot B
4	INH2	Inhibit	Slot B
5	PG3	Power Good	Slot C
6	INH3	Inhibit	Slot C
7	PG4	Power Good	Slot D
8	INH4	Inhibit	Slot D
9	GINH	Global inhibit	
10	ACOK	AC mains signal	
11	+5V	Global 5V Bias	
12	COM	Common	

Note that for modules requiring more than 1 slot, the INHx and PGx use the highest number available for x. The other controls will have no function. E.g. For an OPA2 fitted in slots AB, INH1 & PG1 have no function while INH2 and PG2 provide the usual functions for the module.

All of the signals are referenced to the bias supply common rail (COM) and external control and/or monitoring circuits can be easily powered and interfaced to the PSU through this connector. The entire signals circuit is fully medically isolated and can be considered a SELV output. The table below lists the isolation voltages.

Signals isolation voltages		
Signals to Input	4000 <sup>(1)</sup>	Vac
Signals to Chassis	250	Vdc
Signals to Output	250	Vdc
Notes	1. Testing an assembled unit to 4000VAC may cause damage. Please refer to application note (APN-002) on Vox Power website or contact Vox Power representative.	

### 5V bias supply (Power)

A 5V bias supply that can deliver up to 1A is provided as standard on all units. This supply is available whenever the AC mains voltage is connected and the input module is operating correctly. To ensure safety, the following abnormal conditions may cause the entire unit to latch off, which will disable the 5V bias supply:

- Over temperature of any part of the unit
- Over voltage on the output
- Internal over current (device failure)

### AC mains signal (ACOK [Output])

An ACOK signal is provided to indicate to the user that the AC mains voltage is applied and the input module is operating correctly. The output signal is driven from an internal operational amplifier as shown in the following diagram. Under normal operating conditions this signal gives a warning of 5ms before the output voltage falls below the power good threshold. However, to ensure safety, the following abnormal conditions may cause the entire unit to latch off without an ACOK warning:

- Over temperature of any part of the unit
- Over voltage on the output
- Internal over current (device failure)

### Power Good signals (PG1-PG4 [Output])

Each output module provides a power good (PG) signal to indicate when the output voltage is above approximately 90% of the preset voltage for that module. Each PG signal on an output module is internally connected through an optoisolator to the signals circuit, which buffers the signal through a PNP transistor with a 10k pull down resistor, as shown.

The LED on the front of each module gives a visual confirmation of the PG status.

Note that remote adjustments of the output voltage using the Vcontrol and Icontrol pins do not change the PG signal threshold. The PG threshold is always approximately 90% of the voltage set with the manual potentiometer.

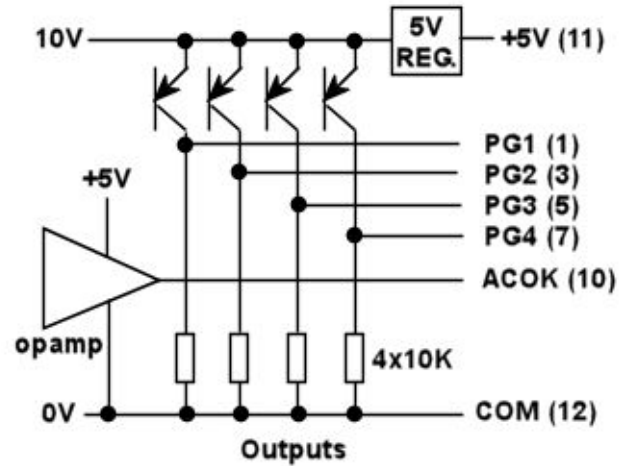

### Output Inhibits (INH1-INH4, GINH [Input])

The signals circuit provides four inhibit inputs to disable each output module individually and a fifth global inhibit input (GINH) to inhibit all modules simultaneously. Each inhibit input is internally connected through an optoisolator to the respective output modules. The basic internal electrical circuit and timing diagrams are shown below. Typically,  $t_{OFF} = 100 \mu s$  and  $t_{ON} = 8 ms$ .

To inhibit each output module individually, GINH should be connected to COM, and 5V applied to the appropriate input INH1/2/3/4. To start with all outputs inhibited and then enable them individually, GINH should be connected to +5V, then pull down the appropriate input INH1/2/3/4. If GINH is left unconnected, then INH1/2/3/4 will all behave as global inhibit inputs. i.e. 5V on any INH input will disable all outputs.

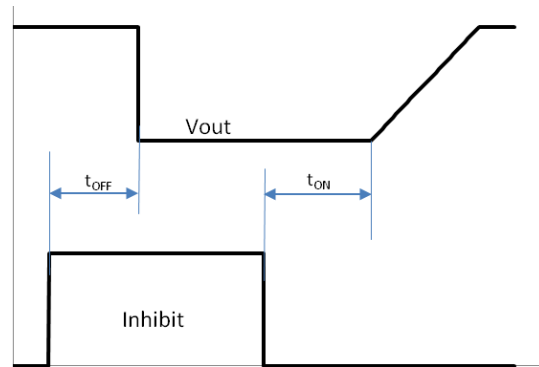
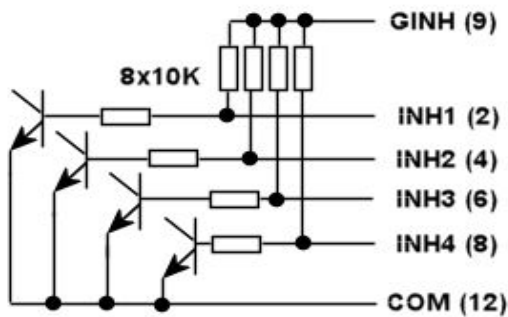



## Single Output module operation

### Power profile

The power profile diagram below is a voltage/current plot that together with the associated table provides details of the main features of the currently available output modules.

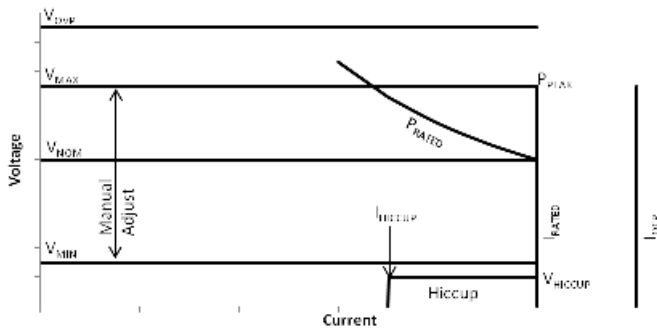

Parameter	OP1	OP2	OP3	OP4	OPA2	OPA3
V <sub>NOM</sub> (V)	5	12	24	48	12	24
V <sub>MIN</sub> (V)	1.5	4.5	9	18	4.5	9
V <sub>MAX</sub> (V)	7.5	15	30	58	15	30
V <sub>OVP</sub> (V)	9.5	18	36	66	18	36
I <sub>RATED</sub> (A)	25	15	7.5	3.75	25	15
I <sub>OCP</sub> (A)	27.5	16.5	8.25	4.125	27.5	16.5
V <sub>HICUP</sub> (V)	1	2	4	4	2	4
I <sub>HICUP</sub> (A)	22	13.2	6.6	3.3	22	13.2
P <sub>RATED</sub> (W)	125	150	150	150	300	300
P <sub>PEAK</sub> (W)	187.5	225	225	217.5	375	450
Slots	1	1	1	1	2	2

### Output voltage adjustment

Each output can be adjusted within the range as described in the table above or in the datasheet. Voltage adjustment can be achieved by two methods;

#### 1. Manual potentiometer adjustment

Using the manual adjust potentiometer, the preset output voltage ( $V_{SET}$ ) of each output module is adjustable over the entire range of  $V_{MIN}$  to  $V_{MAX}$  as specified in the power profile table above. A clockwise rotation of the potentiometer results in an increase of the output voltage while an anti-clockwise rotation results in a decrease of the output voltage.

#### 2. Remote voltage programming

Using remote voltage programming, the output voltage may be adjusted beyond the  $V_{MIN}$  and  $V_{MAX}$  range specified in the power profile table above. However, certain precautions must be taken to ensure correct operation. Please see the "Advanced output module features" section for more details.

### Over Voltage Protection (OVP)

In the event of an output module fault, the modules are protected against excessive output voltages. This is implemented as a fixed voltage threshold ( $V_{OVP}$ , in the table above) and if the output voltage exceeds this threshold the entire chassis will be latched off. To resume operation of the unit, disconnect the AC input voltage for 2 minutes, remove the faulty output module and reconnect the AC input voltage.

Note that no warning is given on the AC\_OK signal for faults of this type.

### Over Current & Short Circuit Protection (OCP & SCP)

For increased safety and reliability all output modules in the NEVO series have over current and short circuit protection. The over current threshold is typically set at 110% of the rated current and has a constant current, straight line characteristic that reduces the output voltage as the load resistance decreases. If the output voltage falls below the hiccup voltage threshold ( $V_{HICUP}$ ) the module enters short circuit protection mode. In this mode the output module uses a hiccup scheme to reduce system losses and potential damage. When in this mode, the output will be enabled for approximately 3% of the time, disabled for 97% and will attempt to restart at approximately 125 ms intervals. The module remains in this state until the short circuit condition is removed, at which point the module returns to normal operation.

### Reverse Current Protection (RCP)

The standard output modules use synchronous rectification in the output stages to achieve high efficiency and as a result the outputs can both source and sink current. The sink current is internally limited to approximately -6% of the maximum rated current. However, in applications where the output modules are connected to external power sources such as batteries or other power supplies certain precautions must be observed to prevent damage to the unit.

The outputs should never be directly connected to external power sources without some form of reverse current protection such as an external diode or controlled mosfet. If protection is not used, large reverse currents which will ultimately result in damage to the unit will occur, especially when the AC mains is disconnected.

### Output module Average and Peak power

All modules have an average and peak power rating. The average power of each unit must at all times remain below its specified limit. However, each output can deliver up to 150% of its average power rating for a maximum of 5 seconds at 50% duty cycle, subject to the current limit not being exceeded and subject to the overall average power drawn being less than the specified average power rating (including any input derating due to temperature or line voltage). The available peak power is a function of the output voltage and maximum current for each module. Full peak power is only possible when the output voltage is adjusted to  $V_{MAX}$  and the maximum current is drawn from the module. Note that both average and peak power ratings are subject to the same temperature derating as the input module (derate by 2.5% per °C above 50°C), but are not subject to any line derating.

### Start-up & Shut down

All outputs are designed to have a regulated monotonic start-up with a rise time of approximately 3ms as shown in the diagram right. The power good signal stays low until the voltage exceeds the power good threshold ( $\approx 90\%$ ).

Where multiple output modules are used, the default start up scheme is ratio-metric with all outputs starting at the same time as shown in the diagram right. External control circuits may be used to implement tracking or sequenced start up if necessary.

The outputs are not designed to start into a pre-biased load and may discharge any externally capacitance before beginning to ramp the output voltage up in the normal way.

At shutdown the outputs enter a high impedance state. Where no external load is present it may take some time for the voltage to decay. When driving inductive loads, care must be taken to limit the voltage at the output terminals so as to prevent damage to the unit.

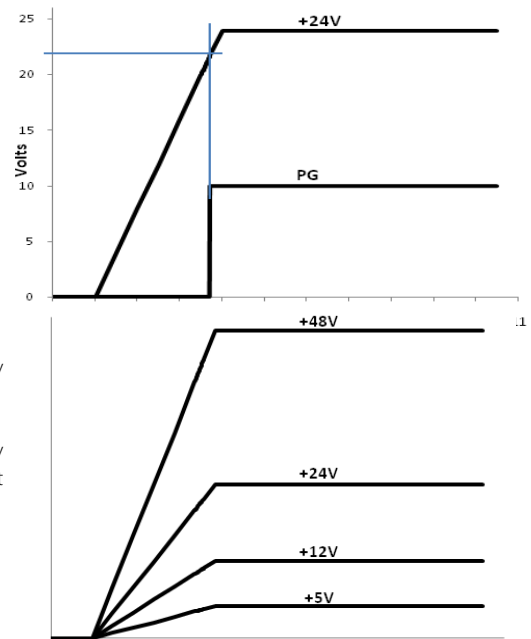

### Synchronisation

All output modules in the same chassis are synchronised. The typical operating frequency is 260kHz and paralleled/seriesed units will not produce beat frequencies.

### Ripple and Noise

The ripple and noise figures stated in the datasheet are defined based on a standard measuring method. To obtain the same results the same test setup must be used and care must be taken to eliminate any parasitic noise pickup. The diagram below shows details of the setup and also sources of noise pickup.

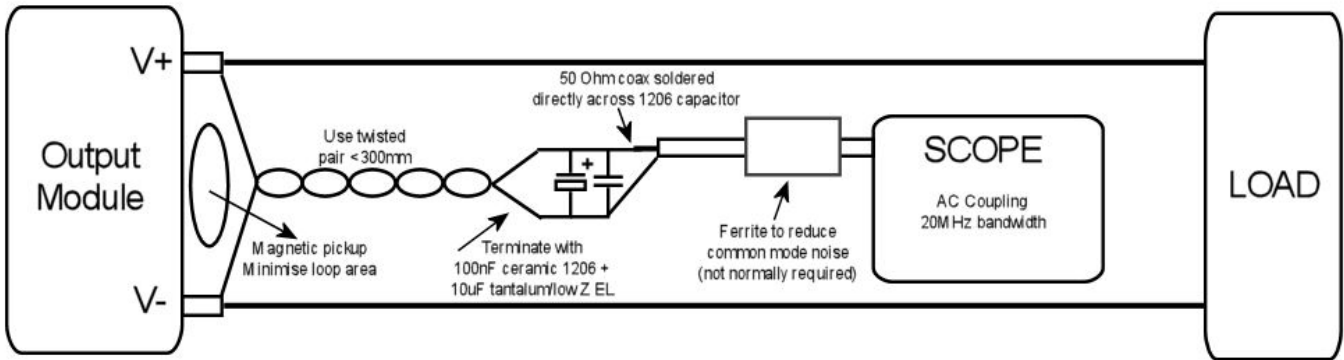

### Over Temperature Protection (OTP)

Each output module is protected against excessive temperatures. In the event of the internal temperatures exceeding safe levels the entire unit may be latched off. To resume operation of the unit, disconnect the AC input voltage for 2 minutes, ensure external ambient temperatures are within specifications and then reconnect the AC input voltage. Note that no warning is given on the AC\_OK signal for faults of this type.

### Transient response

The NEVO output modules have been especially designed to have high reliability and to achieve this all electrolytic capacitors have been eliminated from the design. Due to this, high dynamic load transients can cause relatively high voltage deviations at the output and although the outputs have a very high loop bandwidth with typical recovery times of less than  $100\mu\text{s}$ , the voltage deviations may still be excessive for some applications.

An example application is detailed in the diagram below and shows typical responses at the terminals of the output module and at the load. Notice that the voltage deviation due to cable inductance exceeds the module response and hence a capacitor located at the module terminals will have little effect at the load. The optimum solution is to locate a low impedance electrolytic capacitor at the load which will eliminate the inductive cable drop and also reduce the typical voltage deviation at the module.

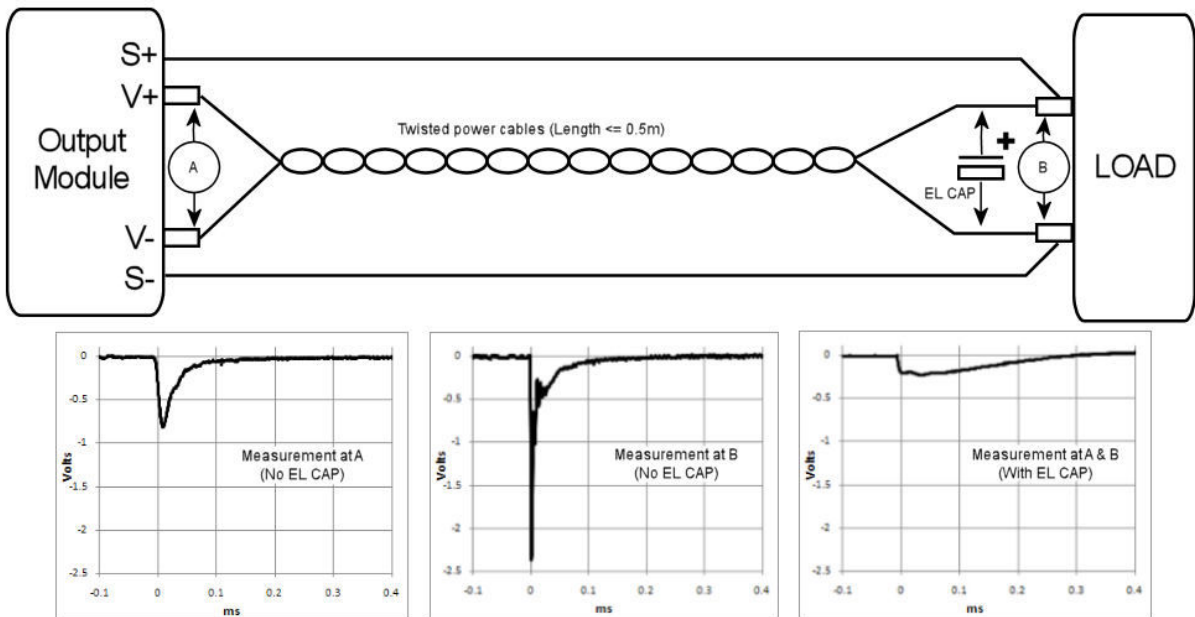

## Advanced Single Output module features

### Remote voltage programming (External voltage control)

The output voltage of the module can be adjusted using an external voltage source connected between the COM and Vcontrol pins on the signals connector J5 as shown below.

In this configuration the output voltage will follow the typical equation below,

$V_o = V_{set}((1.8 - V_{ctrl}) / 0.6)$ , where  $V_{set}$  is the manual preset voltage of the module.

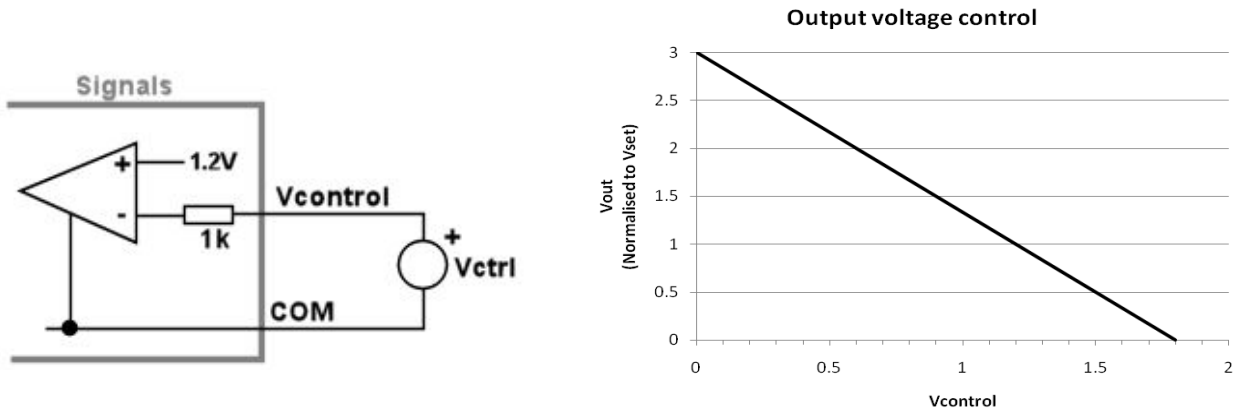

The output voltage can be controlled from 0% to 300% of the preset voltage using this control method. However, care must be taken to ensure the output voltage does not exceed the OVP level, as this is considered a safety hazard and will latch the entire unit off. To determine the level of control voltage that will trigger OVP, insert  $V_{ovp}$  into the equation above.

Example:  $V_{ovp} = 9.5V$ ,  $V_{set} = 5V$ ;

$$\Rightarrow V_{ctrl} = 1.8 - (V_{ovp} * 0.6 / V_{set}) = 0.66V$$

Hence,  $V_{ctrl}$  should never fall below 0.66V, otherwise OVP may latch the entire unit off.

Alternatively, by manually adjusting the output voltage to less than 1/3<sup>rd</sup> of the OVP voltage ensures that OVP can never be tripped by remote voltage control.

Also, remote adjustment of the output voltage using the Vcontrol pin does not affect the preset power good threshold. Hence, remotely adjusting the output voltage below  $0.9 * V_{set}$  will cause the power good signal to go low.

Where tight voltage adjustment tolerances are required, it is recommended to use external circuitry to provide closed loop control of the Vcontrol pin.

### Remote current programming (External voltage control)

The output current limit of the module can be reduced using an external voltage source connected between the COM and Icontrol pins on the signals connector as shown below. In practice this also means that the output can be used as a modulated or constant current source.

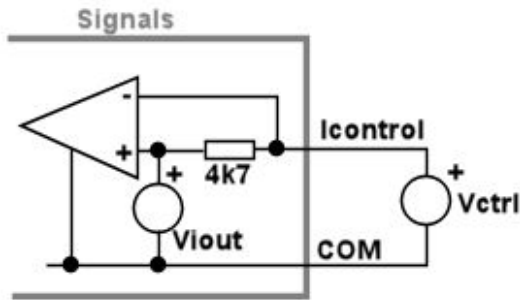

In the diagram above,  $V_{i\_out}$  is an internal voltage source that is proportional to the internal inductor current and approximates the equation,

$$V_{i\_out} = 0.6 + (I_{out}/I_{rated} * 1.25),$$

where  $I_{rated}$  is the maximum rated current for the module.

In this configuration the output current limit will approximate the following equation,

$$I_{limit} = (V_{ctrl} - 0.6) * I_{rated} * 1.25,$$

where  $I_{rated}$  is the maximum rated current for the module.

It is not possible to increase the maximum current limit of the module, and control voltages ( $V_{ctrl}$ ) exceeding 1.53 V will have no effect on the current limit.

When using an output module as a modulated current source, the output voltage should be manually adjusted to the maximum that will be required by the application and this will be the upper voltage limit. Once the load is connected, the output current can then be modulated by applying a control voltage as described above.

Note that the power-good threshold level is fixed and defined by the manually preset voltage. Hence, while the output module is limiting or modulating the output current the PG signal may go low.

Where tight current adjustment tolerances are required, it is recommended to use external circuitry to provide closed loop control of the Icontrol pin.

### Output current measurement

The output current of the module can be measured using the  $I_{control}$  signal. If this pin is unloaded its output voltage will follow the equation,

$$V_{i\_out} = 0.6 + (I_{out}/I_{rated} * 1.25),$$

where  $I_{rated}$  is the maximum rated current for the module.

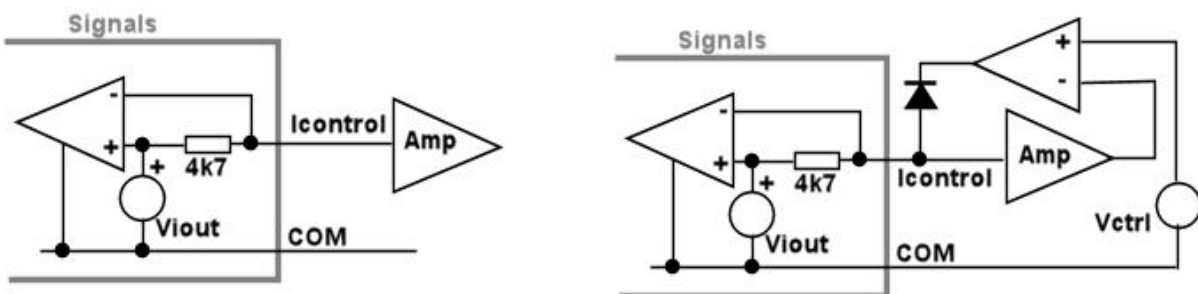

Note that the  $I_{control}$  output voltage is representative of the internal inductor current not the actual load current. However, this will only have an influence during dynamic events. It is recommended to add an external amplifier (as shown above left) when using the  $I_{control}$  signal to measure the output current as loading the  $I_{control}$  signal, even with microamps can cause the current limit to be reduced. If it is required to measure the output current and adjust the output current limit simultaneously, this can be achieved by using a clamp circuit instead of a voltage source to adjust the current limit, while continuing to use an amplifier to measure the output current. An example circuit is shown above right. In this case  $V_{ctrl}$  will control the current limit while the amplified  $I_{control}$  signal will provide a measurement of the output current.

### Remote sensing

Remote sensing is available on all output modules and can be used to compensate for any voltage drop in the main power leads between the power supply and the load. To implement remote sensing connect the positive sense pin (S+, connector J5.2) to the positive side of the remote load and the negative sense pin (S-, connector J5.1) to the negative side of the remote load. The voltage will be regulated at the points where the sense cables are connected.

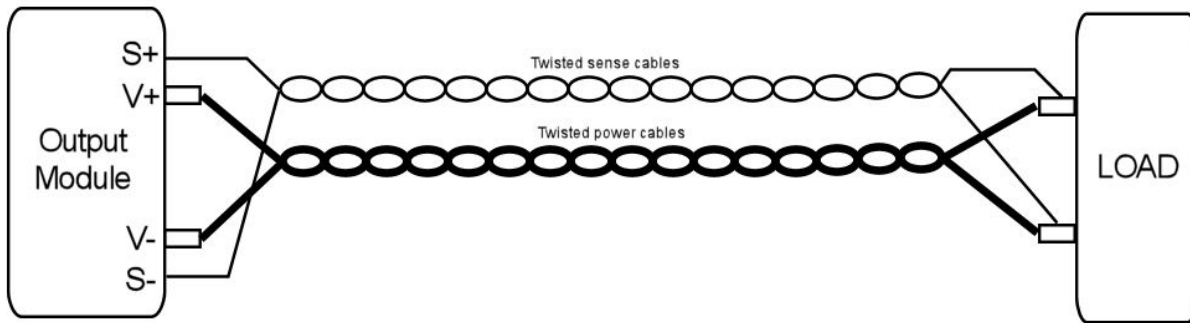

Active protection against worn out power cables or accidental power cable removal is provided and prevents damage to the unit in each case. An internal circuit measures the voltage between S+ to V+ and S- to V-, when this voltage exceeds the thresholds specified in the datasheet, the output voltage is reduced to benign levels. During system design, care must be taken to ensure power cables have a sufficiently low voltage drop at maximum load current to ensure this protection does not activate unintentionally.

In systems where remote sensing is not used, the output voltage at the power terminals will be slightly higher than that at the sense terminals. This voltage difference is termed, open sense offset and occurs due to internal bias currents in the sensing circuit. Factory set units are set with the sense cables connected unless otherwise specified.

#### Local Bias supply

A local non-isolated +5 V bias supply is provided on each output module (+5 V on J5.6, referenced to COM on J5.5). This supply is intended to power interface circuits for monitoring and controlling the output modules, such as amplifying the current output signal as described earlier. The output can supply up to 10mA maximum, and exceeding this can damage the unit.

Also, as COM is connected to an internal voltage that is **NOT** equivalent to S- or V-, particular attention must be given to grounding issues when interfacing COM to any control circuit in the application. Connecting COM to S- or V- may result in damage to the unit.

## Series Connected outputs

NEVO output modules of the same type can be seriesed in any number to achieve higher output voltages, even across multiple chassis! The following instructions must be followed for output modules configured in this manner.

**WARNING!**  
Energy and voltage hazards may arise when individual modules are seriesed.  
See the Safety section for more details.

**WARNING!**  
When modules are seriesed, their inhibit lines (J2), if used, should be paralleled.  
Inhibiting seriesed modules individually may cause damage

### Isolation to ground

Care must be taken not to exceed the output module isolation to chassis ground when seriesing outputs. Each output is rated for 250 volts maximum between each output terminal and chassis ground. Exceeding this voltage may damage the unit.

### Remote sensing

For seriesed modules, remote sensing is achieved by connecting the upper most positive sense terminal (S+) and the lower most negative sense terminal (S-) from the series of modules to their respective load regulation points. All inner sense terminals in the series must be daisy chained, S+ to S- from the first module in the series to the last module in the series. An example of two seriesed modules is shown below.

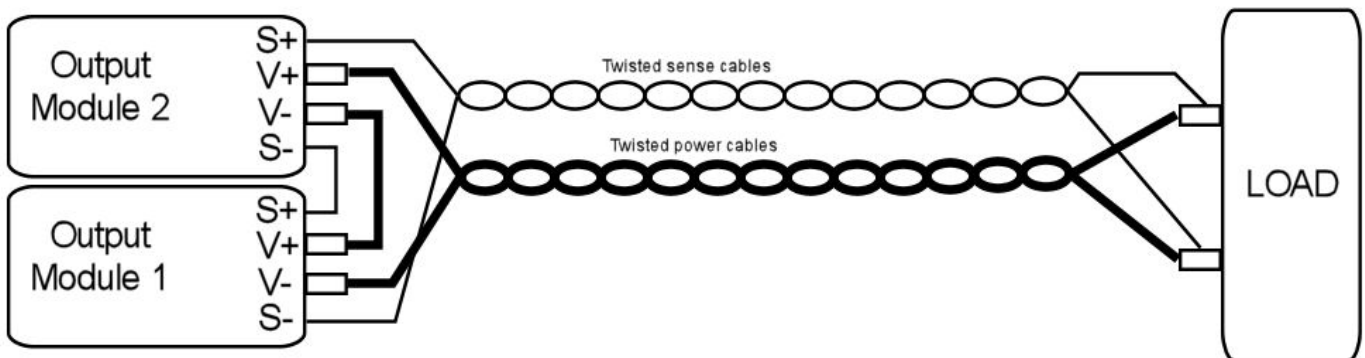

### Seriesed remote voltage/current control

Remote voltage and/or current control is possible with series connected output modules using the advanced V-control and I-control functions as described earlier. However, individual control of each module can be complex as the various control terminals are referenced to the positive output of the preceding module and require the use of multiple isolated control voltages to attain control over the full voltage range. In practice, individual control of each module is rarely required and a more straightforward method is to control all outputs simultaneously with a single control voltage. With NEVO output modules this is achieved with the use of the NEVO Series Tracker Interface, the datasheet for this interface is available from the Vox Power website i.e. [www.vox-power.com](http://www.vox-power.com). By using the series tracker interface all modules in a series can be controlled by a single control voltage that can be referenced to the COM (J5.5) pin on any module.

### SELV precautions

Where series combinations of output modules exceed 60 V, the output can no longer be considered SELV (Safety Extra Low Voltage) and hence the final equipment manufacturer must provide suitable protection for both users and service personnel.

## Paralleled outputs

NEVO single type output modules of the same type can be paralleled in any number within the same chassis to achieve higher output currents. When paralleled, the outputs can operate in two distinct modes, Normal parallel mode or Share parallel mode.

### WARNING!

Energy hazards may arise when individual modules are paralleled.  
See the Safety section for more details.

### WARNING!

When modules are paralleled, their inhibit lines (J2), if used, should also be paralleled.  
Inhibiting paralleled modules individually may cause damage

### Normal parallel mode

For normal parallel mode, the positive power cables should be connected together and the negative power cables should be connected together. No other connections are required.

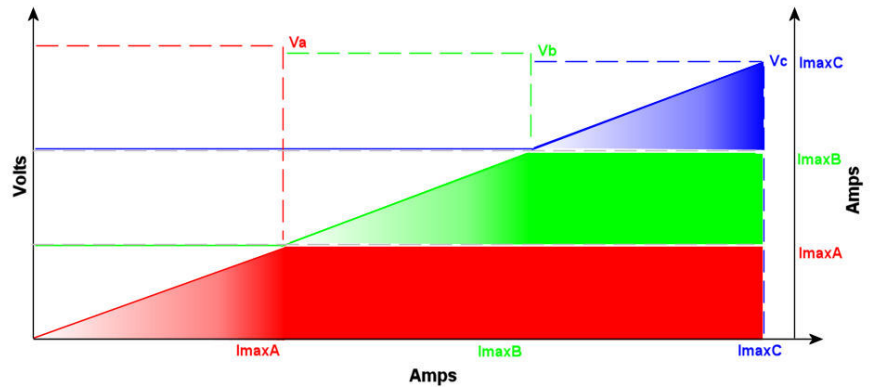
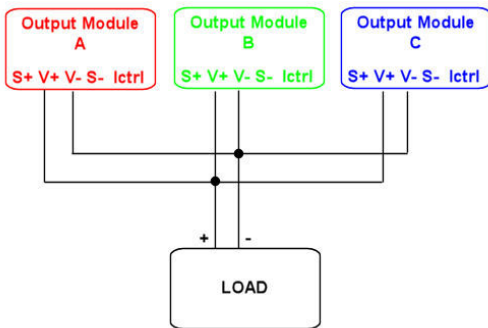

In this mode the highest adjusted output module will supply all of the load current until its current limit is reached. If the load demand exceeds this level the output voltage will drop to the level of the next highest adjusted module and that module will begin to supply the load current while the first module continues delivering full current. This process repeats for the total number of paralleled modules. The diagram above shows the VI curve for such a system.

For best output voltage stability, the output voltages of each paralleled module should be adjusted as close as possible.

Output modules that are not delivering current will typically sink a small amount of current from the other outputs, but this will not exceed -6% of each modules maximum rated current.

Typically, system reliability is reduced in this mode as the higher adjusted modules will do most of the work with the lower adjusted modules only delivering current during peak load demand.



### Share parallel mode

In Share parallel mode, the outputs are paralleled as before and the Icontrol pin for each module is connected together as shown in the diagram below.

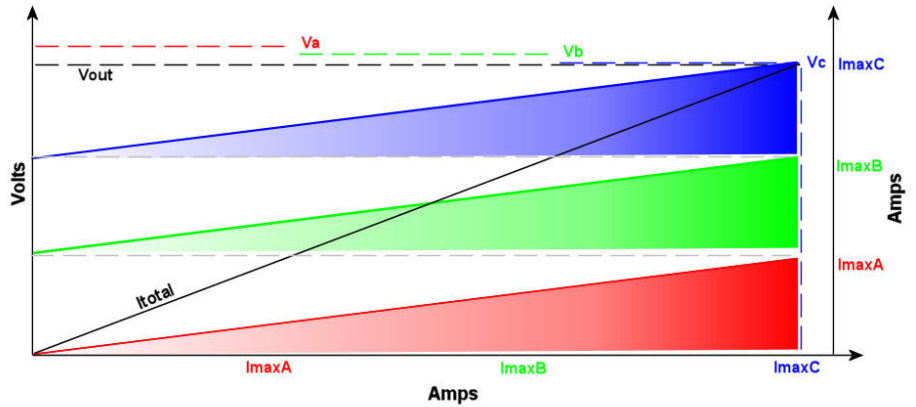
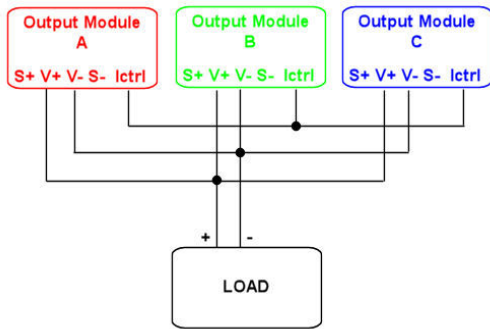

Connecting the Icontrol pins together forces all the outputs to deliver the same current, ensuring that the system reliability is maximised and the work load is distributed evenly across all paralleled modules.

In this mode the lowest adjusted output module will determine the actual output voltage and all higher adjusted outputs will reduce their voltage. There may be a small amount of circulating current between the modules, approximately 6% of the maximum rated current for each module.

The current output signal (Icontrol) can still be used to measure the output current but it must be scaled by N, where N is the number of paralleled modules.

#### **WARNING!**

Care must be taken to avoid differential voltages between the negative power output terminals of the paralleled modules as this can cause errors at the control pins. To avoid this, it is recommended that a low impedance connection be made between the negative power terminals close to the PSU output and cables then connected from this common point to the load.

### Paralleling across multiple chassis

Paralleling across multiple chassis is not possible without external protection (such as external diodes or controlled MOSFETs) to prevent circulating currents between each chassis. Failure to provide such protection may result in damage to the units. Consult Vox Power for details on how best to implement such applications.

Where units are paralleled across multiple chassis, the outputs in each chassis will not be synchronised and the peak to peak output ripple may contain beat frequencies in the audio spectrum.

### Parallel remote sensing

Remote sensing can be used as normal with paralleled modules. The sense lines (S+ and S-) from each of the output modules should be connected together, S+ to S+, and S- to S- as shown below. This should be done close to the power supply output and a single pair of cables brought from these sense lines to the load. Keeping cable lengths to a minimum and using twisted pairs where necessary will help reduce noise pickup in the sense lines.

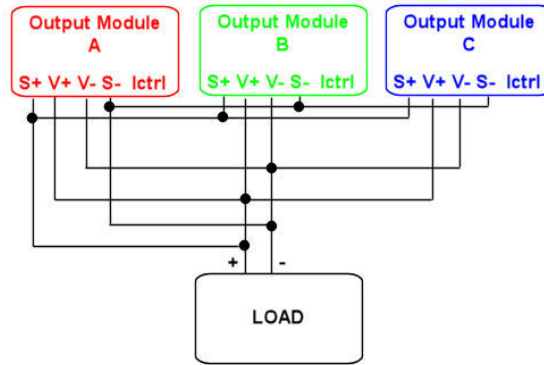

### N+1 configurations

When using N+1 redundant configurations, a suitably rated diode (or controlled MOSFET) must be used on each output to prevent a device failure from causing a system failure. However, the diode introduces voltage drops between the supply and the load that significantly degrade the load regulation. To counteract this, the remote sense lines can be used to regulate the voltage at the load as shown below.

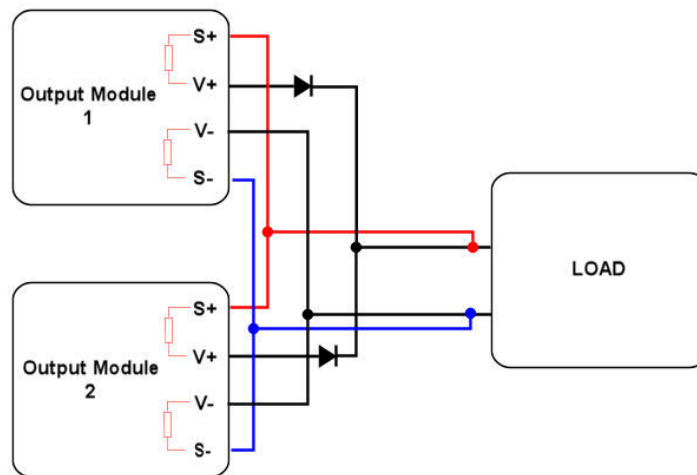

Typically, this configuration can damage the internal sense resistors used within a power supply. However, the NEVO outputs have integrated protection to prevent this type of damage and are completely N+1 compatible without any additional external protection circuitry. Note that only the positive sense terminal is protected and diodes should be used in the positive connection only.

### Paralleled remote voltage/current adjust

Remote voltage programming with paralleled outputs can be achieved by simply joining all  $V_{CONTROL}$  and COM pins together and applying the external control voltage between COM and  $V_{CONTROL}$ .

Remote current programming with paralleled outputs can be achieved by joining all  $I_{CONTROL}$  and COM pins together but directly applying an external control voltage would override the current share signal and force the outputs to operate in normal parallel mode. Instead it is required to clamp the  $I_{CONTROL}$  bus voltage using a circuit similar to that shown below.

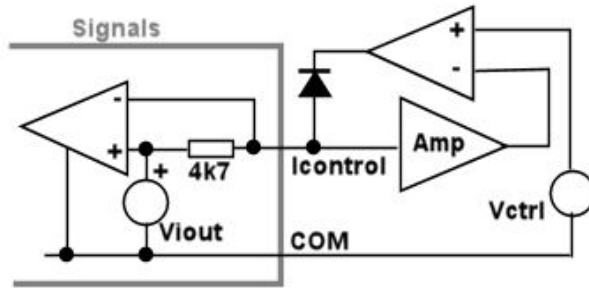

It is not recommended to use remote voltage/current programming in normal parallel mode.

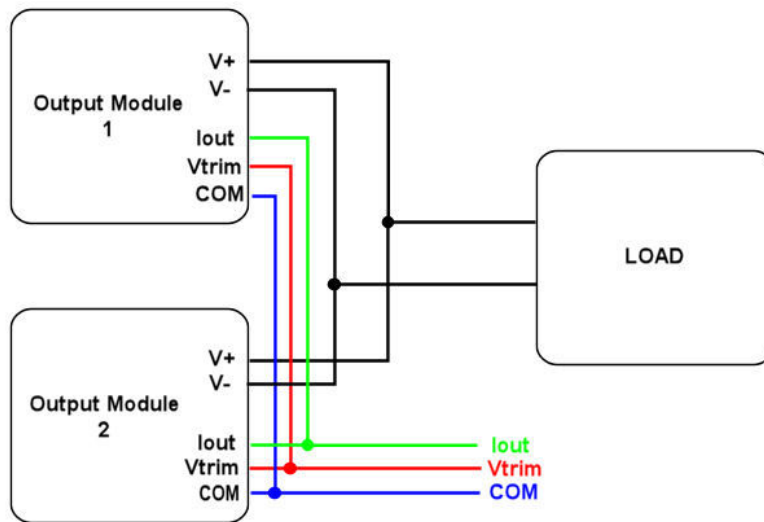

#### WARNING!

Care must be taken to avoid differential voltages between the negative power output terminals of the paralleled modules as this can cause errors at the control pins. To avoid this, it is recommended that a low impedance connection be made between the negative power terminals close to the PSU output and cables then connected from this common point to the load.

## Dual Output module operation

### Power Profile

The power profile diagram below is a voltage/current plot that together with the associated table provides details of the main features of the currently available dual output modules.



Parameter	OP5*		OP8	
	Top	Bottom	Top	Bottom
V <sub>NOM</sub> (V)	12	12	24	24
V <sub>MIN</sub> (V)	3.3	3.3	-	-
V <sub>MAX</sub> (V)	15	15	-	-
V <sub>OVP</sub> (V)	22	22	30	30
I <sub>RATED</sub> (A)	5	5	3.125	3.125
I <sub>OCP</sub> (A)	6.5	6.5	4.5	4.5
P <sub>RATED</sub> (W)	75	75	75	75

\* Specifications are for updated OP5 modules. Serials beginning with 18xxxxxxxx.

### Output voltage adjustment

Each output can be adjusted within the range as described in the table above or in the datasheet. Voltage adjustment can be achieved using the manual adjust potentiometer, the preset output voltage ( $V_{SET}$ ) of each output module is adjustable over the entire range of  $V_{MIN}$  to  $V_{MAX}$  as specified in the power profile table above. A clockwise rotation of the potentiometer results in an increase of the output voltage while an anti-clockwise rotation results in a decrease of the output voltage.

Remote voltage programming is not available on dual output modules.

### Over Voltage Protection (OVP)

In the event of an output module fault, the modules are protected against excessive output voltages. This is implemented as a fixed voltage threshold ( $V_{OVP}$ , in the table above) and if the output voltage exceeds this threshold the entire chassis will be latched off. To resume operation of the unit, disconnect the AC input voltage for 2 minutes, remove the faulty output module and reconnect the AC input voltage.

Note that no warning is given on the AC\_OK signal for faults of this type.

### Over Current Protection (OCP)

For increased safety and reliability all dual output modules in the NEVO series have over current protection. The over current threshold is typically set at 130% of the rated current and has a hybrid constant current - hiccup mode characteristic. If the load current exceeds the  $I_{OCP}$  threshold the unit will initially hold the current constant at the OCP level by reducing the output voltage. However, should the load be increased further and the output voltage fall below approximately 70% of its set point, the unit will enter hiccup mode. The output will remain off for a certain period and then attempt to restart. The module remains in this state until the over load condition is removed, at which point the module returns to normal operation.

Note that hiccup mode current limit schemes can cause startup issues in certain circumstances where load currents plus any capacitive charging currents exceed the current limit. For reliable designs the user should ensure the worst case measured startup current does not exceed 90% of the rated current.

### Reverse Current Protection (RCP)

NEVO Dual output modules use synchronous rectification in the output stages to achieve high efficiency and as a result the outputs can both source and sink current. The sink current is internally limited to approximately -6% of the maximum rated current.

Dual output modules should never be directly connected to external power sources without some form of reverse current protection such as an external diode or controlled mosfet. If protection is not used, large reverse currents which will ultimately result in damage to the unit will occur, especially when the AC mains is disconnected.

### Start up & Shut down

All outputs are designed to have a regulated monotonic start-up with a controlled rise time which is specified in the datasheet. The power good signal stays low until the voltage for both outputs is within the power good threshold range ( $\approx 95\%$ ).

Dual outputs are designed to start into a pre-biased load without causing any discharge.

At shutdown the outputs enter a high impedance state. Where no external load is present it may take some time for the voltage to decay. When driving inductive loads, care must be taken to limit the voltage at the output terminals so as to prevent damage to the unit.

### Synchronisation

All dual output modules in the same chassis are synchronised. The typical operating frequency is 260kHz and seriesed units will not produce beat frequencies.

### Ripple and Noise

The ripple and noise figures stated in the datasheet are defined based on a standard measuring method. To obtain the same results the same test setup must be used and care must be taken to eliminate any parasitic noise pickup. The diagram below shows details of the setup and also sources of noise pickup.

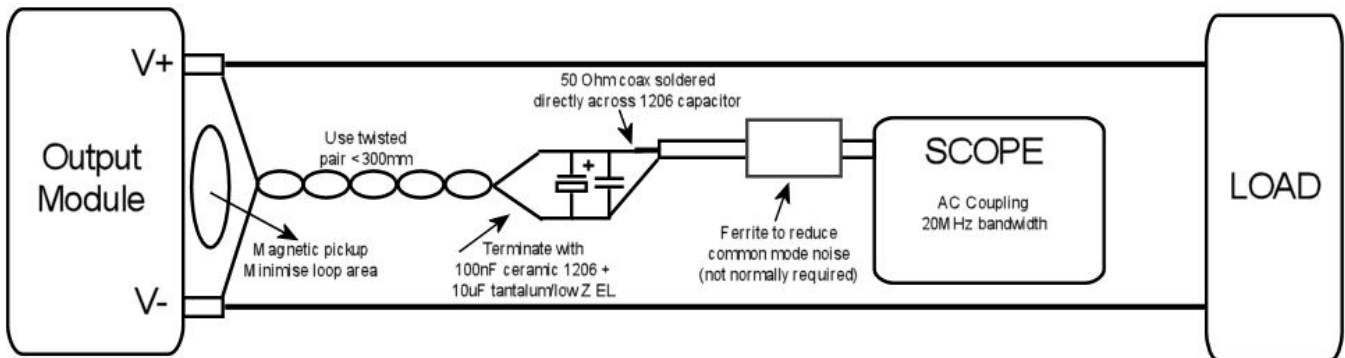

### Over Temperature Protection (OTP)

Each output module is protected against excessive temperatures. In the event of the internal temperatures exceeding safe levels the entire unit may be latched off. To resume operation of the unit, disconnect the AC input voltage for 2 minutes, ensure external ambient temperatures are within specifications and then reconnect the AC input voltage. Note that no warning is given on the AC\_OK signal for faults of this type.

### Transient response

The NEVO Dual output modules have been especially designed to have high reliability and to achieve this, electrolytic capacitors have been minimised or eliminated from the design. As a result, the typical output capacitance of the module is relatively low and high dynamic load transients can cause relatively high voltage deviations at the output. Where this causes an application issue, external low impedance electrolytic capacitance may be added to improve the transient response. However, for Dual output modules the maximum recommended external capacitance is 680uF. Exceeding this value may cause startup issues.

### Series & Parallel operation

NEVO Dual Output modules cannot be paralleled. Paralleling dual output modules may result in damage.

NEVO Dual Output modules can be seriesed.

### Temperature Derating

For Dual Output modules the temperature derating factor applies to output current not output power.

### Remote sensing

Remote sensing is available on all Dual output modules and can be used to compensate for a small voltage drop in the main power leads between the power supply and the load. To implement remote sensing connect the positive sense pin [S+, connector J5.1 (Top) or J5.3 (Bottom)] to the positive side of the remote load and the negative sense pin [S-, connector J5.2 (Top) or J5.5 (Bottom)] to the negative side of the remote load. The voltage will be regulated at the points where the sense cables are connected.

In systems where remote sensing is not used, the output voltage at the power terminals will be slightly higher than that at the sense terminals. This voltage difference is termed, open sense offset and occurs due to internal bias currents in the sensing circuit. Factory set units are set with the sense cables connected unless otherwise specified.

### Isolation

Each output channel in a NEVO Dual output module is fully isolated. Each output is rated for 250 volts maximum between each output terminal and chassis ground. Exceeding this voltage may damage the unit.

## Audible noise

The following series of plots characterise the audible noise from the NEVO+600 (S & M Model) power supply over various conditions. These plots can be used to estimate the actual audible noise for any application. The SL & ML Models are approximately 18dB lower than the S & M Models.

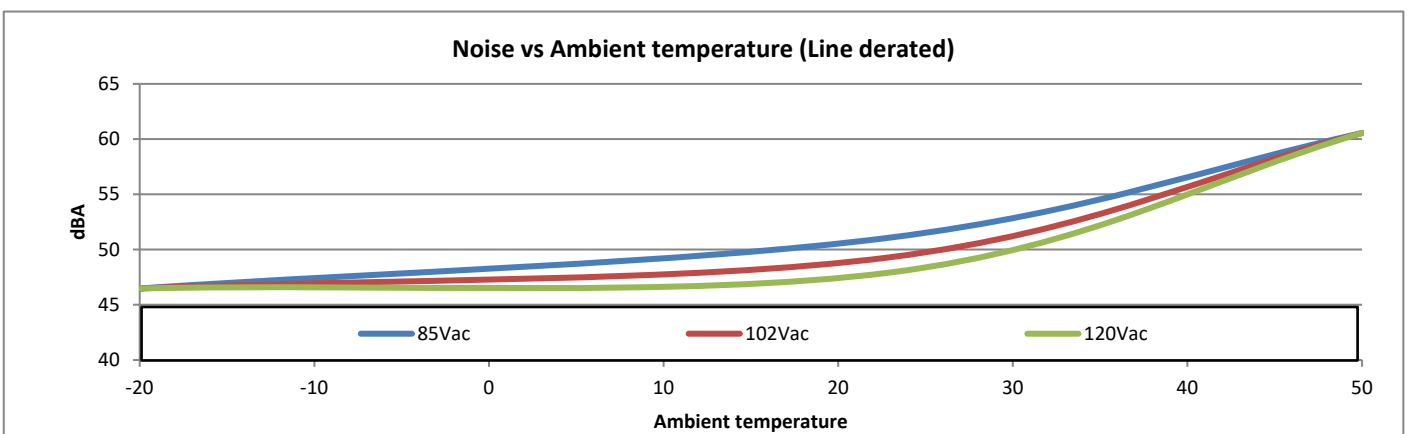
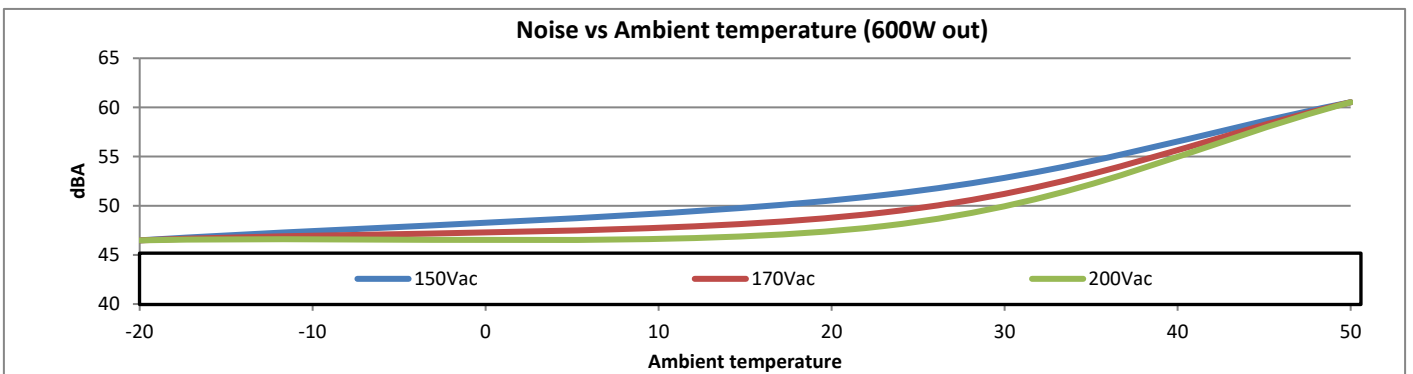
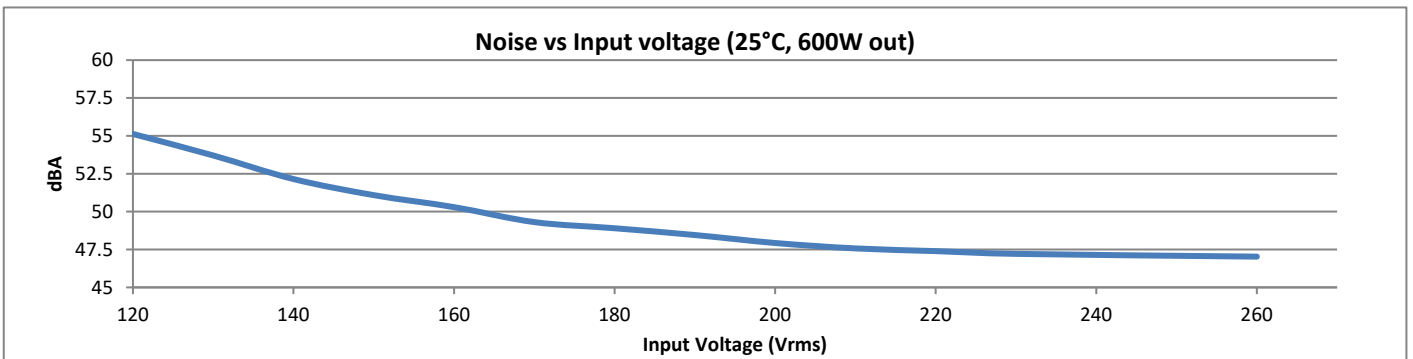
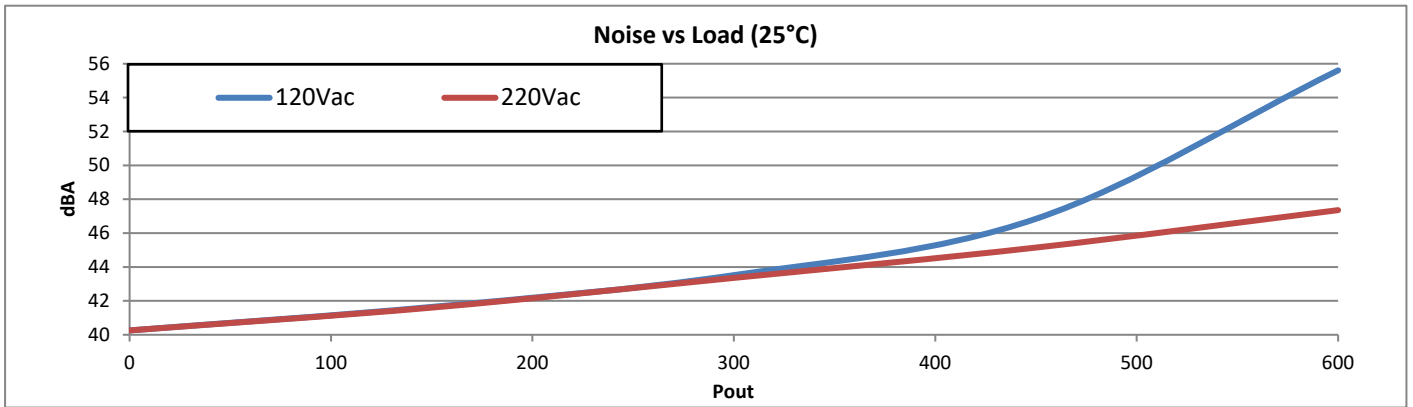

## Mechanical dimensions and mounting

MECHANICAL DIMENSIONS AND MOUNTING SCREWS			
SCREWS			
LOCATION	DETAILS	PENETRATION	TIGHTENING
MOUNTING	M4 x 4	<b>4mm max, including chassis</b>	0.55 NM
OUTPUT MODULES	M3 x 5, Countersink Posi, 8 Places	Defined by screw	0.5 NM
CHASSIS LID	M3 x 30, Countersink Posi, 2 Places M3 x 5, Countersink Posi, 5 Places M2.5 x 4, Countersink Posi, 1 Places	Defined by screw	0.5 NM

Torque settings are for general reference only. The torque settings shown are the insert manufacturers recommended values.

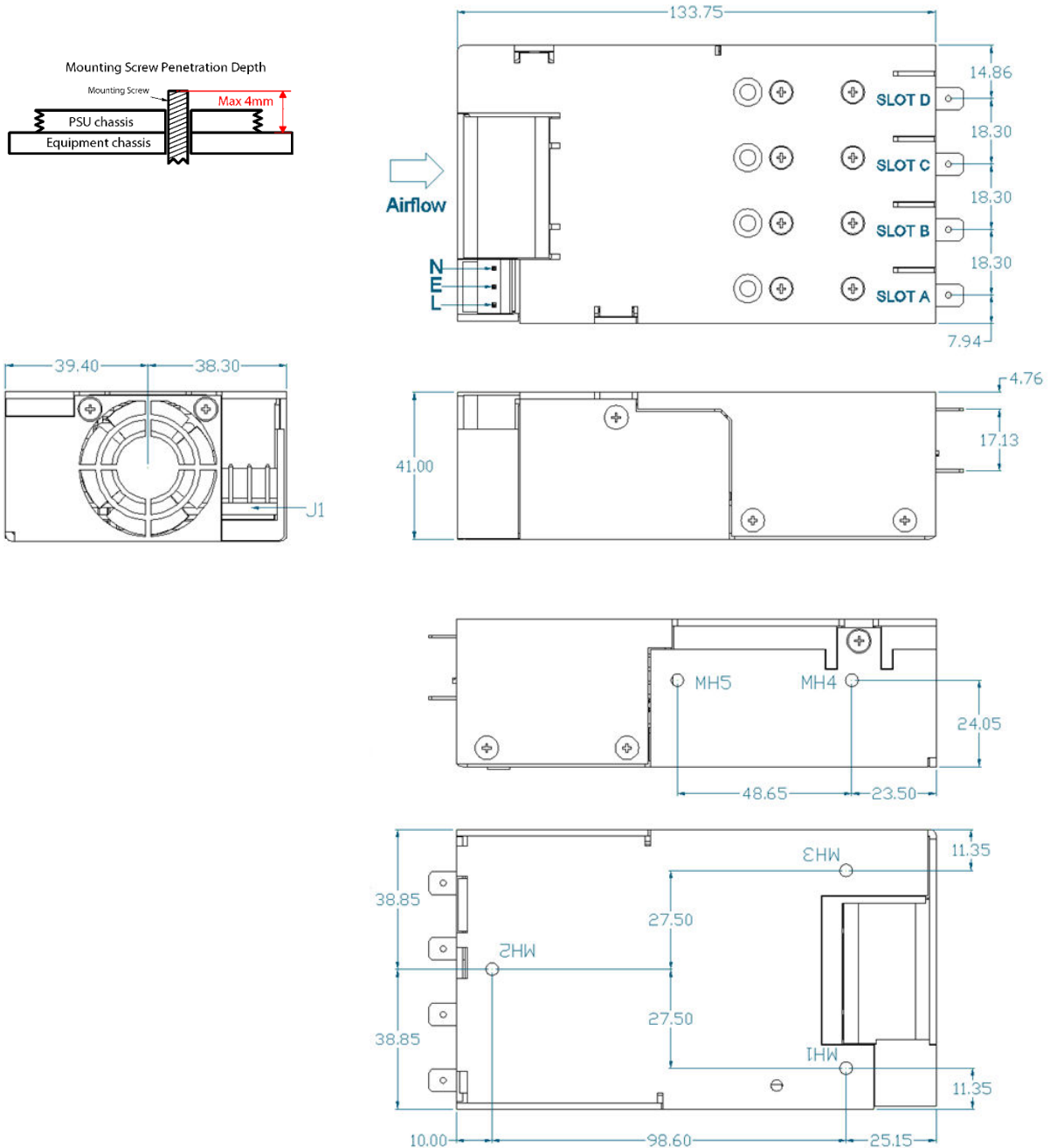

Unless stated otherwise, all dimensions are in millimetres and in accordance with DIN2768-1/2 CLASS C

Airflow cannot be reversed

# Connectors

PINOUTS		
J1		
Circuit	Details	
1	Live	
2	Earth	
3	Neutral	
J2		
Circuit	Details	
1	Power Good	Slot A
2	Inhibit	
3	Power Good	Slot B
4	Inhibit	
5	Power Good	Slot C
6	Inhibit	
7	Power Good	Slot D
8	Inhibit	
9	Global Inhibit	
10	AC OK	
11	+5V 1A Bias Supply	
12	COM	
J3		
Circuit	Details	
1	Positive Output	
J4		
Circuit	Details	
1	Negative Output	
J5		
Circuit	Details	
1	- Sense	
2	+ Sense	
3	Voltage Control	
4	Current Control / Share / Out	
5	COM	
6	+5V 10mA local bias supply	

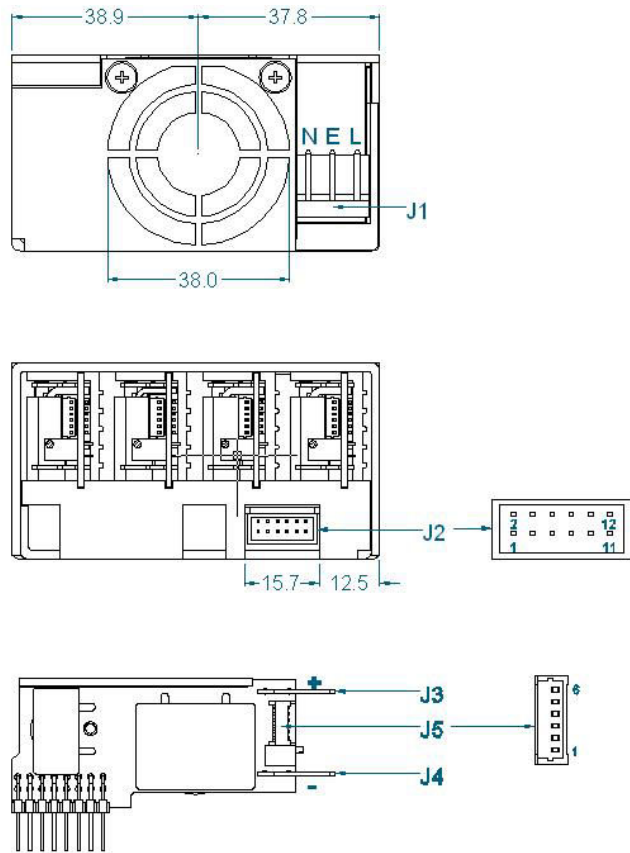

## MATING PART DETAILS

REF.	DETAILS	MANUFACTURER	HOUSING	TERMINAL
J1	MAINS INPUT: 3 Pin, 5.08mm, with Friction Lock, 18-24 AWG	MOLEX	10013036	8701031
J2	GLOBAL SIGNALS: 12 Pin, 2mm, with Friction Lock, 24-30 AWG	MOLEX	511101251	503948051
J2	IDT ALTERNATIVE FOR J2	MOLEX	875681273	N/A
J3/J4 <sup>(1)</sup>	OUTPUT POWER TERMINAL: TAB SIZE 6.35mmx0.8mm	VARIOUS	N/A	N/A
J5	OUTPUT SIGNALS: 6 Pin, 1.25mm, with Friction lock, 28-32 AWG	MOLEX	1510210600	50058800

### Notes

- Terminal and Wire current rating must exceed maximum short circuit output current. Eg. Output 1 = 25A\*1.25 = 31.25Amps
- Direct equivalents may be used for any connector parts
- All cables must be rated 105°C min, equivalent to UL1015



## Configuring your power supply

The NEVO+600 power supply is designed to be used as part of an end-system in a restricted environment and therefore should only be accessible to qualified and trained personnel. Persons attempting to configure a unit must have the necessary knowledge and training before doing so. Incorrect configuration may cause damage to the power supply and may affect the warranty of the power supply.

Output power modules may be added, replaced or moved by strictly following the sequence of operations described below. Please contact Vox Power or your distributor for assistance in configuring your power supply.

### STEP 1:

Remove the power connection and all other connections from the power supply.

#### **WARNING!**

Leave the unit to stand for a minimum of 3 minutes after removing all power and other connections from the unit before attempting to configure or re-configure the power supply.

Always remove the power before handling the unit. During operation the external surface of the unit can become hot. Leave to stand for 10 minutes to allow the unit to cool down before handling the unit.

Dangerous voltages are present within the power supply. Covers may only be removed by qualified personnel when the power supply has been disconnected from the mains supply voltage for more than 3 minutes. Covers must be replaced and all screws secured properly before reconnecting to the mains voltage.

### STEP 2:

Remove all screws. There are 2 screws for the fan, 6 screws on the sides and 8 on the top (2 for each slot). The lid can now be removed. Ensure that all the output modules are loose from the lid before removing the lid.

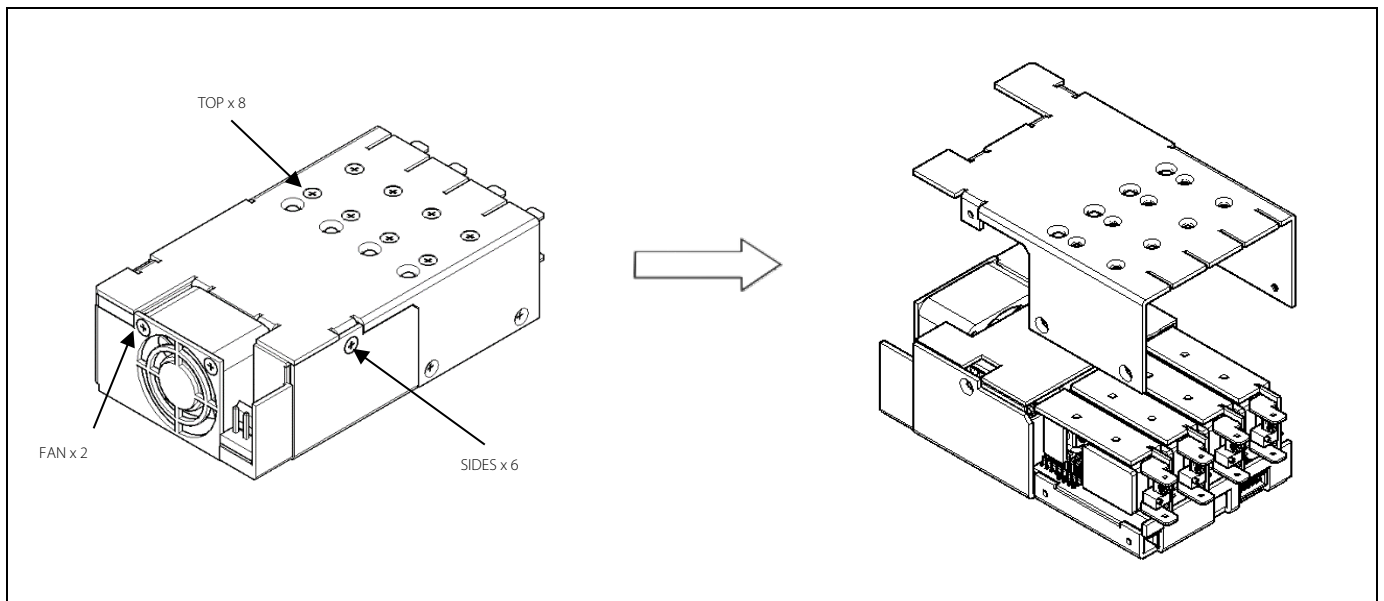

STEP3:

Once the lid is removed modules can be removed and replaced as required. For single slot modules, a single 15 pin header on the output module plugs directly into the connector on the input module PCB. For dual slot modules, a dual 15 pin header on the output module plugs directly into two connectors on the input module PCB. Note that there are no placement restrictions for dual slot modules. To insert the output modules, carefully align the required input and output connectors, then push down firmly ensuring not to cause any mechanical damage to the output module connector. Do not remove the plastic cover on the front-end of the unit.

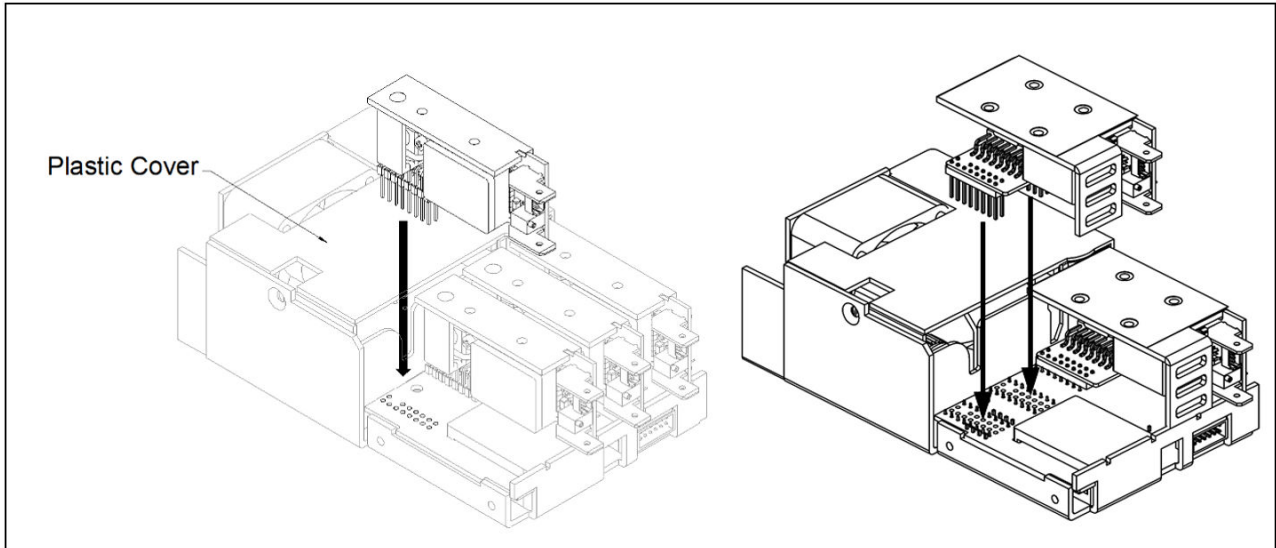

STEP 4:

Once the modules are replaced and the new configuration is complete and the lid can be closed again. A blanking plate must always be used whenever a slot does not contain an output module. Attach blanking plates to the lid before closing it. Ensure the plastic cover is in place before closing the lid again. When closing the lid ensure that each output module slots properly into its corresponding slot in the lid. Insert all the screws and tighten to 0.5Nm. Do not over tighten.

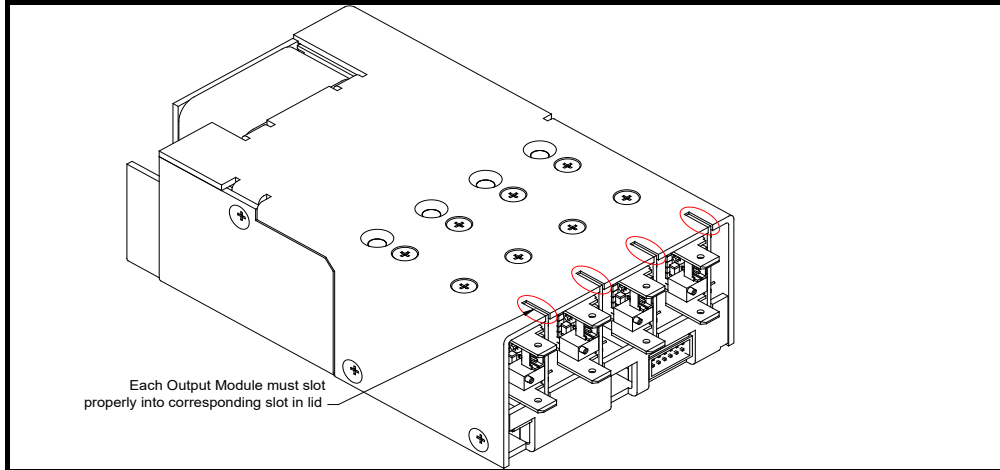

**WARNING!**  
Do not apply power to the power supply before replacing the lid and securing all the screws.

STEP 5:

Reconnect the power cable and apply power to ensure all the output modules are working by checking that the LED light on each output module comes on. Always check the output voltage of each module to ensure it is adjusted to your requirements. Remove power and attach all other cables. The unit is now ready for use.

### PARALLEL LINK INSTALLATION:

NEVO single output modules of the same type can be paralleled in any number within the same chassis to achieve higher output currents. For best performance, the output voltages of each paralleled module should be adjusted to the same set point or as close as possible. For more accurate current sharing pin 4 of the J5 connectors of each modules need to be connected together. To achieve this connection Vox Power has a range of current sharing links available. Please discuss your requirements with your distributor or with Vox Power before ordering your unit.

- Install by sliding the smaller part of the parallel link over the top connectors and the larger part of the parallel link over the bottom connectors to ensure access to the bottom screw as shown.
- Ensure the screw head is pointing up as shown.
- Install so that the terminal clips in the links are closest to the unit as shown.

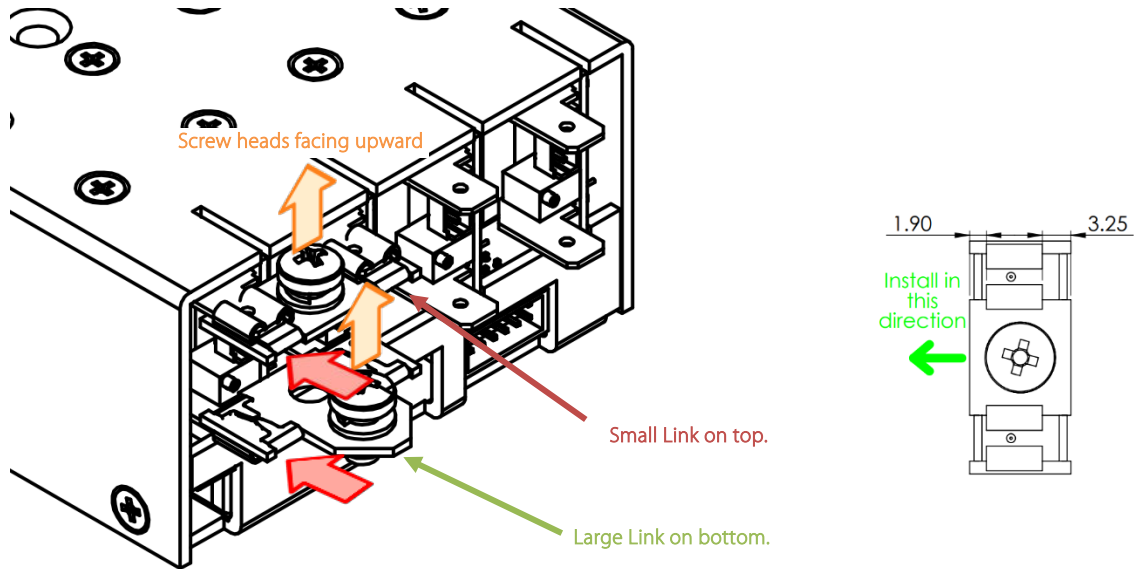

Link shown above is Par2 Link. The same principal applies to Par 3 and Par4 links.

### SERIES LINK INSTALLATION:

NEVO output modules of the same type can be series connected to achieve higher output voltages. Below is an illustration of how to series connect two output modules in Slot A and B with the series link shown separately. For example, if there is a requirement for 80Vdc it can be achieved by connecting two OP4 outputs in series. By repeating steps 1 to 5 of the previous section 'Configuring Your NEVO Product' insert two OP4 output modules, one each in Slot A and B (or any other slot as the configuration requires). Adjust each of the OP4 output modules to 40Vdc as per step 5. Connect the two OP4 output modules in series using the series link. The series link connects the negative output of the OP4 output module in Slot A to the positive output of the OP4 output module in Slot B. Measure the output voltage between the positive output terminal of OP4 in Slot A and the negative output terminal of OP4 in Slot B. You should measure 80Vdc. For more information on how to connect two or more modules in series please see the 'Series Connected Outputs' section in the NEVO Series Installation Notes.

Install series links as shown below with tab pointing away from unit. Orientate the series link such that the vertical segment is in line with the output PCB.

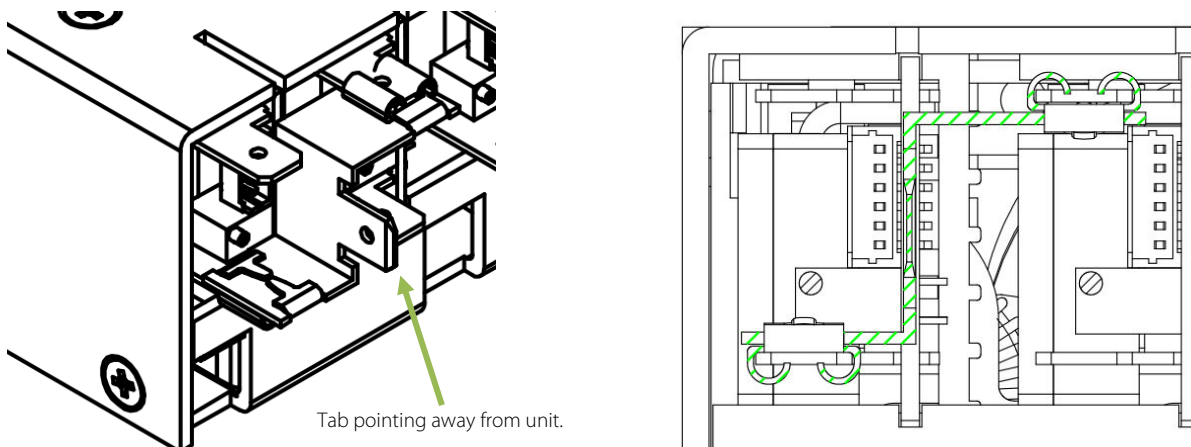

### Safety

The NEVO unit has been designed to comply with the Low Voltage Directive DIR 2014/35/EU (LVD), the EMC Directive DIR 2014/30/EC and DIR 2011/65/EU regarding the restriction of certain hazardous substances and is CE marked to show its compliance

When correctly installed (according to the installation manual) in a limited access environment the NEVO+600S complies with the requirements of IEC/EN/UL/CSA 62368-1, IEC/EN/UL/CSA 60950-1 and the NEVO+600M complies with the requirements of IEC/EN/CSA 60601-1.

The power supply should not be operated close to combustible materials or atmosphere.

Care should be taken to ensure liquid or metal shavings do not enter the power supply as this can cause a fire hazard.

The power supply does not contain any user serviceable parts and should be returned to Vox Power for repair.

#### Approval limitations (NORTH AMERICA)

When this product is used with 180VAC–253VAC mains where no neutral is present, connect the two live wires to L (Live) and N (Neutral) on the input connector.

### WARNING!

Seriesed modules with combined voltages exceeding 60 volts are not considered SELV. Paralleled and/or seriesed modules with combined energy ratings greater than 240 VA may cause energy hazards. The equipments manufacturer must provide additional and adequate protection to service and technical personnel.

Always remove the power before handling the unit. During operation the external surface of the unit can become hot. Leave to stand for 10 minutes to allow the unit to cool down before handling the unit.

Dangerous voltages are present within the power supply. Covers may only be removed by qualified personnel when the power supply has been disconnected from the mains supply voltage for more than 3 minutes. Covers must be replaced and all screws secured properly before reconnecting to the mains voltage.

Parameter	Details	Min	Max	Units
Isolation voltage	Input to Output. <b>Do not perform test on assembled unit<sup>(1)</sup></b>		4000	Vac
	Input to Chassis		1500	Vac
	Output to Chassis		250	Vdc
	Output to Output		250	Vdc
Isolation clearance	Primary to Secondary (Reinforced)	7		mm
	Primary to Chassis (Basic)	2.5		mm
Isolation creepage	Primary to Secondary (Reinforced)	12		mm
	Primary to Chassis (Basic)	4		mm
Leakage current	Medical: 265 Vac, 63 Hz, 25°C		300	µA
	Standard: 265 Vac, 63Hz, 25°C		1500	
Agency Approvals	cURus, Demko, CB Certificate			
Standards	IEC/EN/UL/CSA 62368-1 (2 <sup>nd</sup> Edition); IEC/EN/UL/CSA 60950-1 (2 <sup>nd</sup> Edition); IEC/EN/CSA 60601-1; (3 <sup>rd</sup> Edition) CE Mark: DIR 2014/35/EU (LVD), the EMC Directive DIR 2014/30/EU and DIR 2011/65/EU			
Agency File Numbers	UL : E316486			
Notes	1. Testing an assembled unit to 4000VAC may cause damage. Please refer to application note (APN-002) on Vox Power website or contact Vox Power representative.			

## EMC compliance

To support compliance of the final system design with the EMC directive 2014/30/EU, the NEVO PSU has been designed and tested to the following standards.

ELECTROMAGNETIC COMPLIANCE – EMISSIONS		
Phenomenon	Basic EMC Standard	Test Details
Radiated emissions, electric field	EN55011/22, FCC	Class B compliant
Conducted emissions	EN55011/22, FCC part 15, CISPR 22/11	Class B compliant
Harmonic Distortion	IEC61000-3-2	Compliant
Flicker & Fluctuation	IEC61000-3-3	Compliant

ELECTROMAGNETIC COMPLIANCE – IMMUNITY		
Phenomenon	Basic EMC Standard	Test Details
Electrostatic discharge	IEC61000-4-2	Test level 4: 15kV air, 8kV contact
Radiated RF EM fields	IEC61000-4-3	Test Level 3: (10V/m, 80MHz-2.7GHz) sine wave AM 80% 1kHz
Proximity fields from RF wireless communications equipment	IEC61000-4-3	Test levels as per IEC60601-1-2:2014 Table 9
Electrical Fast Transients/bursts	IEC61000-4-4	Test Level 3: (2kV Power, 1kV I/O) 5kHz(ed3) & 100kHz(ed4)
Surges	IEC61000-4-5	Test Level 3: 1kV L-N, 2kV L-E
Conducted disturbances induced by RF fields	IEC61000-4-6	Test Level 3: 10V, 0.15 to 80Mhz sine wave AM 80% 1kHz
Power Frequency Magnetic Fields	IEC61000-4-8	Test level 4: 30A/m 50Hz
Voltage Dips	IEC61000-4-11 <sup>(2)</sup>	0% 10ms, 0% 20ms (Criterion A) 70% 0.5s, 40% 200ms (Criterion A at 240V and Criterion B at 100V)
Voltage interruptions	IEC61000-4-11	0% 250/300 cycle as per IEC60601-1-2:2014 (Criterion B)
Notes:		
<ol style="list-style-type: none"> <li>Criterion A = No degradation of performance or loss of function. Criterion B = Temporary degradation of performance or loss of function is allowed, provided the function is self-recoverable. Criterion C = Temporary loss of function is allowed but requires operator intervention to recover.</li> <li>Tested at nominal range (100V to 240V). Line deratings applied where appropriate.</li> </ol>		

For radiated and conducted emissions, compliance of the final system relies on proper installation of the PSU component. The installation guidelines detailed below should be followed.

### Installation guidelines for EMC

NEVO units should be mounted within a metal enclosure using the mounting fixtures provided. If the application enclosure is not metal then a metal ground plate should be used to mount both the power supply and the load.

Decoupling the loads to the chassis or ground plate with suitably rated 100nF capacitors can assist in reducing emissions.

Both input and output cables should be fixed as close as possible to the ground plate or metal enclosure. Also, input and output cables should be separated as much as possible.

Output power and sense cables should be twisted pairs and routed parallel to each other. Do not twist sense and power cables together.

All cables lengths and loop areas should be minimised.

Where cables must enter or exit the enclosure, good high frequency 100nF decoupling capacitors of sufficient voltage rating should be connected to the cables as close to the entry/exit point as possible.

For further details or assistance contact Vox Power.

## Reliability

The NEVO series has undergone extensive testing, including HALT and Environmental testing. Reliability data is collected on an ongoing basis. Please contact Vox Power or your distributor for the most up to date reliability data.