



**ISOLATED DC-DC CONVERTER
CHASSIS MOUNT
CFB600W-110SXX-CMFD SERIES
APPLICATION NOTE**



Approved By:

Department	Approved By	Checked By	Written By
Research and Development Department	Enoch	Hugo	Sam
		Jacky	
Quality Assurance Department	Ryan	Benny	



CHASSIS MOUNT CFB600W-110SXX-CMFD Series

Application Note V11 January 2019

Contents

1. Introduction	3
2. DC-DC Converter Features	3
3. Electrical Circuit Diagram	3
4. Terminal Block	3
5. Technical Specifications	4
6. Main Features and Functions	8
6.1 Operating Temperature Range	8
6.2 Output Voltage Adjustment	8
6.3 Over Current Protection	8
6.4 Output Over Voltage Protection	8
6.5 Remote On/Off	8
6.6 UVLO (Under Voltage Lock Out)	8
6.7 Over Temperature Protection	9
7. Applications	9
7.1 Connection for standard use	9
7.2 Convection Requirements for Cooling	9
7.3 Thermal Considerations	9
7.4 Derating	9
7.5 Power Derating	10
7.6 Hold up Time	12
7.7 Efficiency VS. Load	13
7.8 Test Set-Up	14
7.9 Output Voltage Adjustment	14
7.9.1 Output Voltage Trim Range($\pm 10\%$)	14
7.9.2 Output Voltage Trim Range(-40%, +10%)	14
7.10 Output Remote Sensing	14
7.11 Output Ripple and Noise	15
7.12 Output Capacitance	15
7.13 Remote On/Off Circuit	15
8. Safety & EMC	16
8.1 Input Fusing and Safety Considerations	16
8.2 EMC Considerations	16
9. Part Number	20
10. Mechanical Specifications	20
10.1 Mechanical Outline Diagrams	20



CHASSIS MOUNT CFB600W-110SXX-CMFD Series

Application Note V11 January 2019

1. Introduction

The CFB600W-110SXX-CMFD series of chassis mountable DC-DC converters offers 600 watts of output power @ single output voltages of 12, 24, 28, 48VDC. It has a wide (4:1) input voltage range of 43 to 160VDC (110VDC nominal) and 2250VDC basic isolation.

High efficiency up to 88%, allowing case operating temperature range of -40°C to 100°C. An optional heat sink is available to extend the full power range of the unit. Very low no load power consumption (25mA), an ideal solution for energy critical systems.

Built-in EMI EN50155, EN50121-3-2 filter. Meet EN45545. The standard control functions include remote on/off (positive or negative) and +10%, -40% adjustable output voltage.

Fully protected against input UVLO (under voltage lock out), output over-current, output over-voltage and over-temperature and continuous short circuit conditions. CFB600W-110SXX-CMFD series is designed primarily for common railway applications of 72V, 96V, 110V nominal voltage and also suitable for distributed power architectures, telecommunications, battery operated equipment and industrial applications.

2. DC-DC Converter Features

- 600W Isolated Output
- Efficiency to 88%
- Fixed Switching Frequency
- 4:1 Input Range
- Regulated Outputs
- Remote On/Off
- Over Temperature Protection
- Over Voltage/Current Protection
- Continuous Short Circuit Protection
- Shock & Vibration Meets EN50155 (EN61373)
- Safety Meets UL60950-1, EN60950-1 and IEC60950-1
- UL60950-1 2nd (Basic Insulation) Approval for DC Modules
- EN50155:2007 for EMC, Environmental and Characteristic
- Build-In EMI Filter
- Fire & Smoke Meets EN45545-2
- Baseplate Cooled

3. Electrical Circuit Diagram

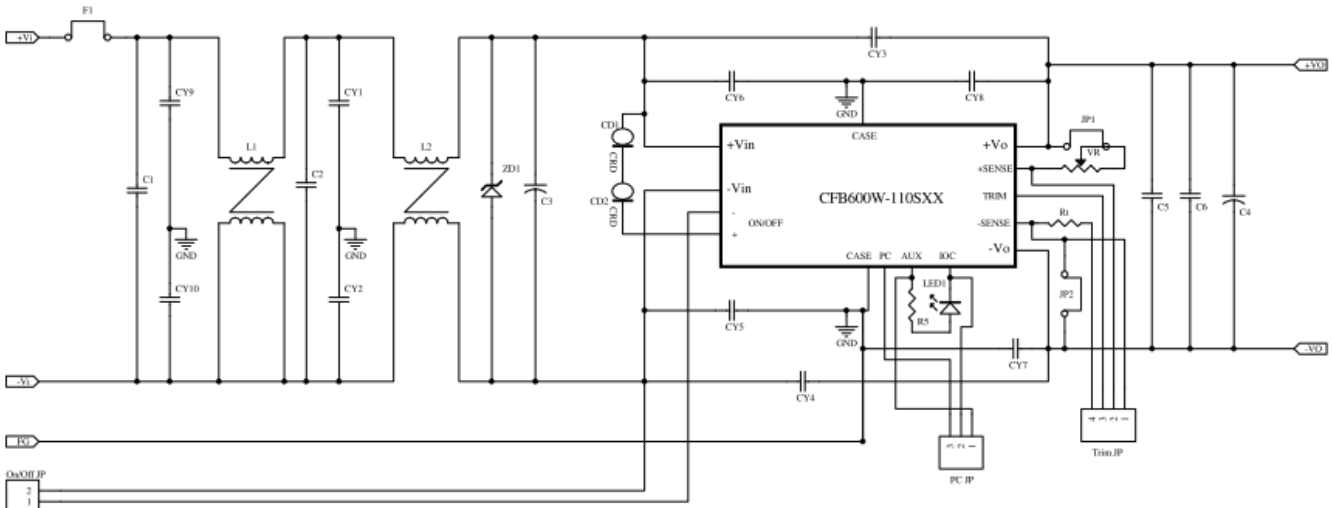

4. Terminal Block

Input and Output Terminal Block

Terminal Type	Screw Torque Value (Kgf-cm)	Suitable Electric Wire (AWG)	Current Rating (max.)
DT-49-B01W-xx or Equivalent	10	12-22	25A



CHASSIS MOUNT CFB600W-110SXX-CMFD Series

Application Note V11 January 2019

5. Technical Specifications

(All specifications are typical at nominal input, full load at 25°C unless otherwise noted.)

ABSOLUTE MAXIMUM RATINGS

PARAMETER	NOTES and CONDITIONS	Device	Min.	Typical	Max.	Units
Input Voltage						
Continuous		All	-0.3		160	V _{dc}
Transient	100ms	All			180	V _{dc}
Operating Case Temperature		All	-40		100	°C
Storage Temperature		All	-40		105	°C
Isolation Voltage	1 minute; input/output	All			2250	V _{dc}
	1 minute; input/case	All			2250	V _{dc}
	1 minute; output/case	All			1500	V _{dc}

INPUT CHARACTERISTICS

PARAMETER	NOTES and CONDITIONS	Device	Min.	Typical	Max.	Units
Operating Input Voltage		All	43	110	160	V _{dc}
Input Under Voltage Lockout						
Turn-On Voltage Threshold		All	41	42	43	V _{dc}
Turn-Off Voltage Threshold		All	39	40	41	V _{dc}
Lockout Hysteresis Voltage		All		2		V _{dc}
Maximum Input Current	100% Load, V _{in} =110V for All	All		6.3		A
No-Load Input Current		110S12		25		mA
		110S24		25		
		110S28		25		
		110S48		25		

OUTPUT CHARACTERISTICS

PARAMETER	NOTES and CONDITIONS	Device	Min.	Typical	Max.	Units
Output Voltage Set Point	V _{in} =Nominal V _{in} , I _o = I _o max, T _c =25°C	V _o =12V	11.88	12	12.12	V _{dc}
		V _o =24V	23.76	24	24.24	
		V _o =28V	27.72	28	28.28	
		V _o =48V	47.52	48	48.48	
Output Voltage Regulation						
Load Regulation	I _o =I _{o_min} to I _{o_max}	All			±2.0	%
Line Regulation	V _{in} =low line to high line	All			±0.2	%
Temperature Coefficient	T _c =-40°C to 105°C	All			±0.03	%/°C



CHASSIS MOUNT CFB600W-110SXX-CMFD Series

Application Note V11 January 2019

PARAMETER	NOTES and CONDITIONS	Device	Min.	Typical	Max.	Units
Output Voltage Ripple and Noise (5Hz to 20MHz bandwidth)						
Peak-to-Peak	Full load, 1uF ceramic capacitor. See 7.11	Vo= 12V			120	mV
		Vo=24V			240	
		Vo=28V			280	
		Vo=48V			480	
RMS.		Vo= 12V			60	mV
		Vo=24V			100	
		Vo=28V			100	
		Vo=48V			200	
Operating Output Current Range		Vo=12V	0		50	A
		Vo=24V	0		25	
		Vo=28V	0		21.4	
		Vo=48V	0		12.5	
Output DC Current Limit Inception	Output Voltage=90% Nominal Output Voltage. See 6.3	All	105		140	%
Maximum Output Capacitance	Full load (resistive)	110S12	0		10000	uF
		110S24	0		10000	
		110S28	0		10000	
		110S48	0		10000	
Power Good Signal(IOG)	Vout ready: low level, sink current	All			20	mA
	Vout not ready: open drain output, applied voltage	All			50	V
Output Voltage Trim Range	P _{out} =max rated power, Trim Adj. Range (By VR), See 7.9.1	All	-10		+10	%
	P _{out} =max rated power, Trim Adj. Range, See 7.9.2	All	-40		+10	%
Output Over Voltage Protection		All	115		140	%

DYNAMIC CHARACTERISTICS

PARAMETER	NOTES and CONDITIONS	Device	Min.	Typical	Max.	Units
Output Voltage Current Transient						
Error Band	75% to 100% of I _{o_max} step load change di/dt=0.1A/us (within 1% Vout nominal)	All			±5	%
Recovery Time		All			500	us
Turn-On Delay and Rise Time	Full load (Constant resistive load)					
Turn-On Delay Time, From On/Off Control	V _{on/off} to 10%V _{o_set}	All		135		ms
Turn-On Delay Time, From Input	V _{in_min} to 10%V _{o_set}	All		135		ms
Output Voltage Rise Time	10%V _{o_set} to 90%V _{o_set}	All		25		ms

EFFICIENCY

PARAMETER	NOTES and CONDITIONS	Device	Min.	Typical	Max.	Units
100% Load	Vin=110V See 7.7	110S12		87		%
		110S24		88		
		110S28		88		
		110S48		88		



CHASSIS MOUNT CFB600W-110SXX-CMFD Series

Application Note V11 January 2019

ISOLATION CHARACTERISTICS

PARAMETER	NOTES and CONDITIONS	Device	Min.	Typical	Max.	Units
Isolation Voltage	1 minute; input/output	All			2250	V _{dc}
	1 minute; input/case	All			2250	V _{dc}
	1 minute; output/case	All			1500	V _{dc}
Isolation Resistance	Input / Output	All	100			MΩ

FEATURE CHARACTERISTICS

PARAMETER	NOTES and CONDITIONS	Device	Min.	Typical	Max.	Units
Switching Frequency	Pulse wide modulation (PWM), Fixed	All	225	250	275	KHz
On/Off Control, Positive Remote On/Off logic, Refer to –Vin pin.						
Logic Low (Module Off)	CN1 On/Off JP	All		Short		
Logic High (Module On)	CN1 On/Off JP	All		Open		
On/Off Control, Negative Remote On/Off logic, Refer to –Vin pin						
Logic High (Module Off)	CN1 On/Off JP	All		Open		
Logic Low (Module On)	CN1 On/Off JP	All		Short		
Auxiliary Output Voltage		All	7	10	13	V
Auxiliary Output Current		All			20	mA
Load Share Accuracy (50%-100% Load)		All	-10		+10	%
Off Converter Input Current	Shutdown input idle current	All			50	mA
Output Voltage Trim Range	P _{out} =max rated power, Trim Adj. Range (By VR), See 7.9	All	-10		+10	%
Output Over Voltage Protection		All	115	125	140	%
Over Temperature Shutdown	Aluminum base plate temperature See 6.7	All		110		°C
Over Temperature Recovery		All		90		°C



CHASSIS MOUNT CFB600W-110SXX-CMFD Series

Application Note V11 January 2019

GENERAL SPECIFICATIONS

PARAMETER	NOTES and CONDITIONS	Device	Min.	Typical	Max.	Units
MTBF	I _o =100% of I _{o_max} ; MIL-HDBK-217F_Notice 1, GB, 25°C	110S12		296		K hours
		110S24		292		
		110S28		275		
		110S48		281		
Weight	CFB600W-110SXX	-CMFD		995		grams
Case Material	Nickel Plating Iron Cover					
Base plate Material	Aluminum					
Potting Material	UL 94V-0(DC MODULE)					
Shock/Vibration	Meets EN50155 (EN61373)					
Humidity	95% RH max. Non Condensing					
Altitude	2000m Operating Altitude, 12000m Transport Altitude					
Thermal Shock	MIL-STD-810F					
EMI	Meets EN50155(EN50121-3-2) with external output filter, see 8.2					
ESD	EN61000-4-2	Level 3: Air ±8kV, Contact ±6kV				Perf. Criteria B
Radiated immunity	EN61000-4-3	Level 3: 80~1000MHz, 20V/m				Perf. Criteria A
Fast Transient	EN61000-4-4	Level 3: On power input port, ±2kV, see 8.1				Perf. Criteria A
Surge	EN61000-4-5	Level 4: Line to earth, ±2kV, Line to line, ±1kV				Perf. Criteria B
Conducted immunity	EN61000-4-6	Level 3: 0.15~80MHz, 10V				Perf. Criteria A
Interruptions of Voltage Supply	EN50155	Class S2: 10ms Interruptions, See 7.6				Perf. Criteria B
Supply Change Over	EN50155	Class C2: During a supply break of 30 ms				Perf. Criteria B
Fire & Smoke	Meets EN45545-2					



6. Main Features and Functions

6.1 Operating Temperature Range

The CFB600W-110SXX-CMFD series converters can be operated within a wide case temperature range of -40°C to 100°C. Consideration must be given to the derating curves when ascertaining maximum power that can be drawn from the converter. The maximum power drawn from chassis mount models is influenced by usual factors, such as:

- Input voltage range
- Output load current
- Forced air or natural convection
- Heat sink optional

6.2 Output Voltage Adjustment

Section 7.9 describes in detail how to trim the output voltage with respect to its set point. The output voltage on all models is adjustable within the range of +10% to -40%.

6.3 Over Current Protection

The converter is protected against over current or short circuit conditions. At the instance of current-limit inception, the module enters a constant current mode of operation. While the fault condition exists, the module will remain in this constant current mode, and can remain in this mode until the fault is cleared. The unit operates normally once the output current is reduced back into its specified range

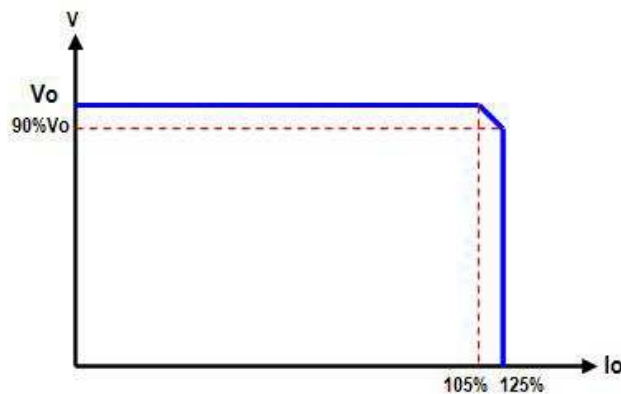

6.4 Output Over Voltage Protection

The converter is protected against output over voltage conditions. When the output voltage is higher than the specified range, the module enters a hiccup mode of operation.

6.5 Remote On/Off

The On/Off input pins permit the user to turn the power module on or off via a system signal from the primary side or the secondary side. Two remote on/off options are available. Negative logic turns the module on as long as a short jumper -on/off and -Vin. Positive logic turns the module off as long as a short jumper -on/off and -Vin. **See 7.13**

Logic State (CN1)	Negative Logic	Positive Logic
Logic Low – Switch Closed	Module on	Module off
Logic High – Switch Open	Module off	Module on

6.6 UVLO (Under Voltage Lock Out)

Input under voltage lockout is standard on the CHB600W-110Sxx-CMFD unit. The unit will shut down when the input voltage drops below a threshold, and the unit will operate when the input voltage goes above the upper threshold.



CHASSIS MOUNT CFB600W-110SXX-CMFD Series

Application Note V11 January 2019

6.7 Over Temperature Protection

These modules have an over temperature protection circuit to safeguard against thermal damage. Shutdown occurs with the maximum case reference temperature is exceeded. The module will restart when the case temperature falls below over temperature recovery threshold. Please measured at point A. (Measuring point A refer to the following figure)

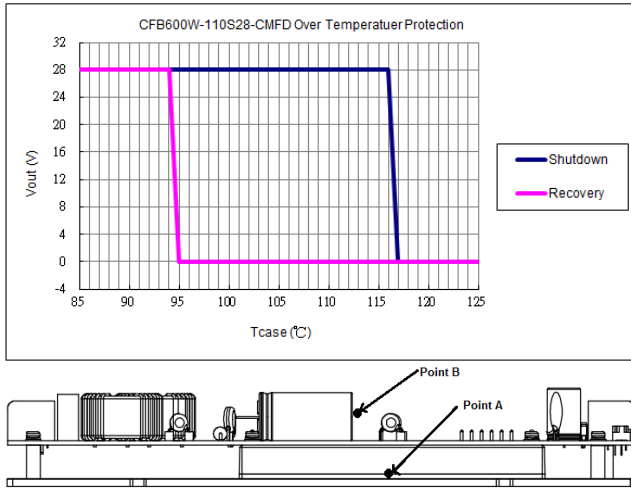

7. Applications

7.1 Connection for standard use

The connection for standard use is shown below. An external output capacitors (C1) is recommended to reduce output ripple and noise, output capacitor recommended 1 uF ceramic capacitor.

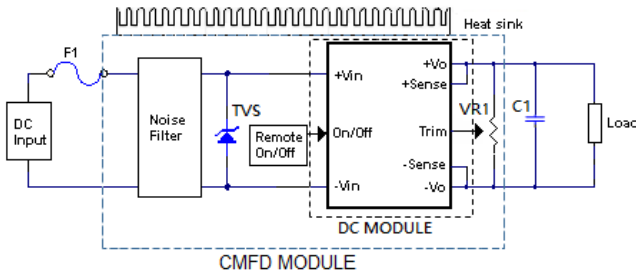

Symbol	Component	Reference
F1	Input fuse	Section 8.1
Noise Filter	Internal input noise filter	Section 8.2
Remote On/Off	External Remote On/Off control	Section 7.13
Trim	Internal output voltage adjustment By variable resistor	Section 7.9
Heat sink	External heat sink	Section 7.4/7.5
+Sense/-Sense	--	Section 7.10

7.2 Convection Requirements for Cooling

To predict the approximate cooling needed for the full brick module, refer to the power derating curves in section 7.5. These derating curves are approximations of the ambient temperatures and

airflows required to keep the power module temperature below its maximum rating. Once the module is assembled in the actual system, the module's aluminum plate (point A) and aluminum capacitor (point B) temperature should be monitored to ensure it does not exceed 100°C.

7.3 Thermal Considerations

The power module operates in a variety of thermal environments; however, sufficient cooling should be provided to help ensure reliable operation of the unit. Heat is removed by conduction, convection, and radiation to the surrounding environment. The example is presented in section 7.5. The power output of the module should not be allowed to exceed rated power ($V_{o_set} \times I_{o_max}$).

7.4 Derating

The following figures are ambient derating curve of CFB600W-110SXX-CMFD based on the aluminum base plate temperature. When operating the CFB600W-110SXX-CMFD series, proper derating or cooling is needed. The maximum case temperature under any operating condition should not exceed 100°C. (Measuring point A and measuring point B refer to the section 6.7)

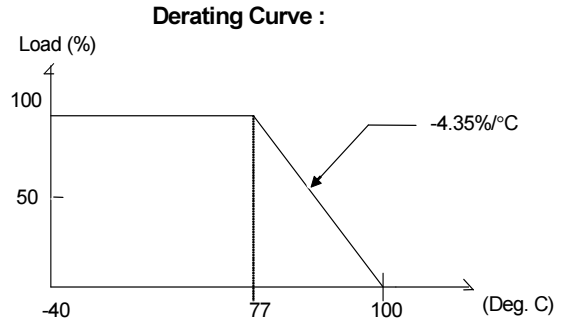

Ambient Derating Curves at Nominal Line, Full Load and Air flow 195CFM, with heatsink (14.17x5.28x1.19inch)



CHASSIS MOUNT CFB600W-110SXX-CMFD Series

Application Note V11 January 2019

7.5 Power Derating

The operating case temperature range of CFB600W-110SXX-CMFD series is -40°C to $+100^{\circ}\text{C}$. When operating the CFB600W-110SXX-CMFD series, proper derating or cooling is needed. The maximum case temperature under any operating condition should not exceed 100°C .

The following curve is the de-rating curve of CFB600W-110SXX-CMFD series with heat sink.

The test condition refer to following figures.

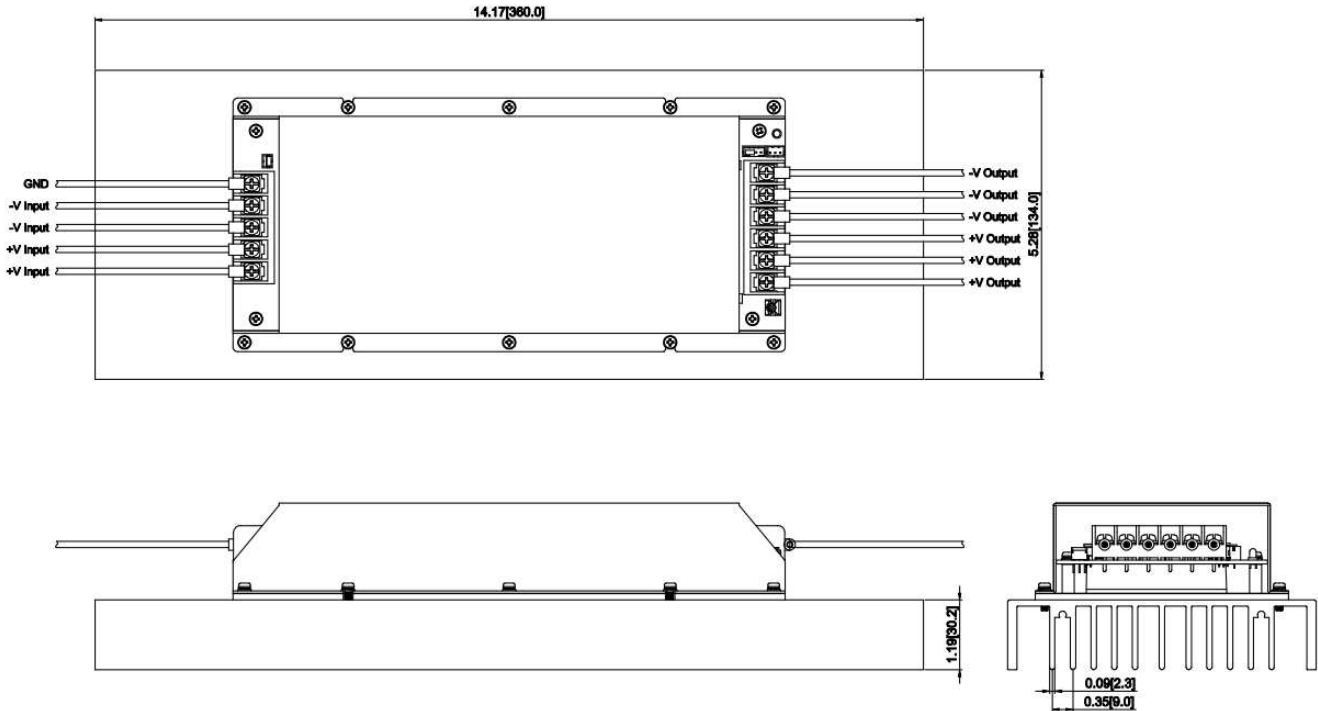



CHASSIS MOUNT CFB600W-110SXX-CMFD Series

Application Note V11 January 2019

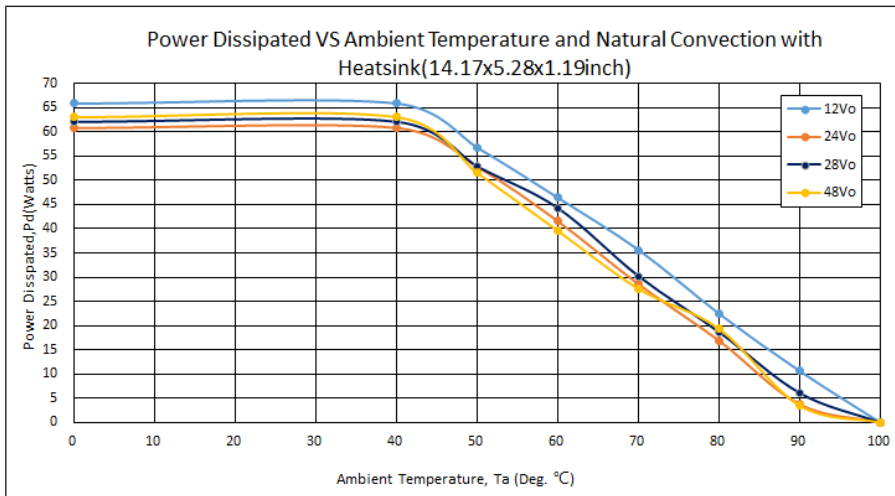

HEATSINK (14.17x5.28x1.19inch)	
AIR FLOW RATE	TYPICAL R _{ca}
Natural Convection 20ft./min. (0.1m/s)	0.9 °C / W

Example (with heat sink):

How to make a CFB600W-110S12-CMFD operating at nominal line voltage, an output current of 34A, and a maximum ambient temperature of 40°C ?

Solution:

Given:

$V_{in}=110V_{dc}$, $V_o=12V_{dc}$, $I_o=34A$

Determine Power dissipation (P_d):

$P_d=P_i-P_o=P_o(1-\eta)/\eta$

$P_d=12.0 \times 34 \times (1-0.86)/0.86=66.4Watts$

Determine airflow:

Given: $P_d=66.4W$ and $T_a=40^\circ C$

Check above Power de-rating curve:

Heat sink with 14.17x5.28x1.19inch

Verify:

Maximum temperature rise is $\Delta T = P_d \times R_{ca}=66.4 \times 0.9=59.76^\circ C$

Maximum case temperature is $T_c=T_a+\Delta T=99.76^\circ C < 100^\circ C$

Where:

The R_{ca} is thermal resistance from case to ambient environment.

T_a is ambient temperature and T_c is case temperatur



CHASSIS MOUNT CFB600W-110SXX-CMFD Series

Application Note V11 January 2019

7.6 Hold up Time

Hold up time is defined as the duration of time that DC/DC converter output will remain active following a loss of input power.

The test condition and test curve refer to following figures.

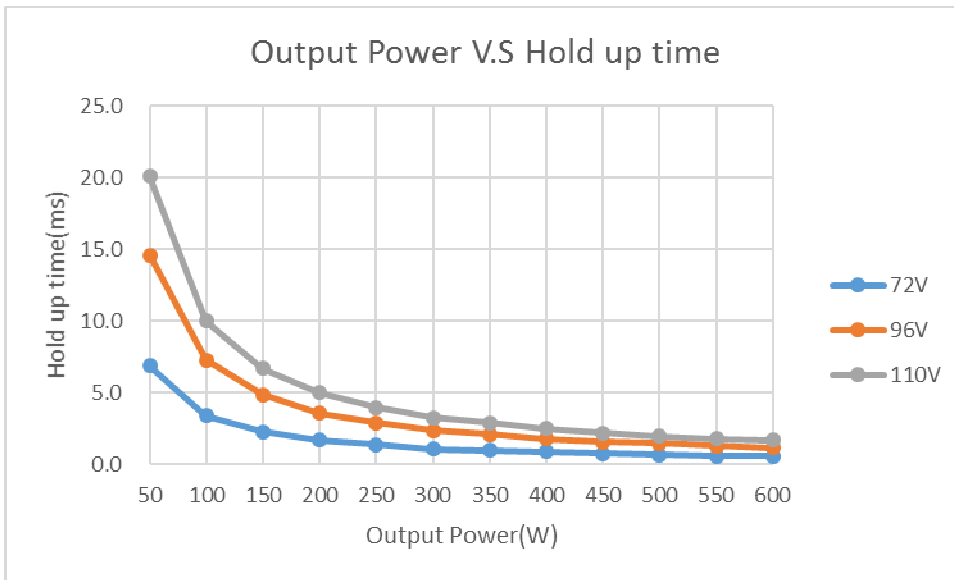
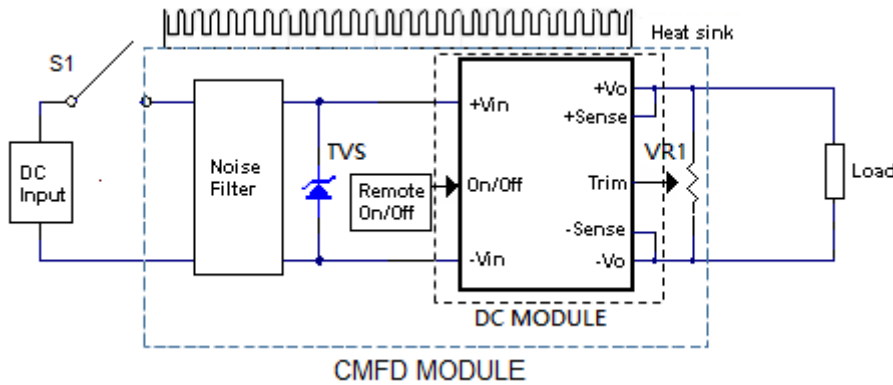

To meet power supply interruptions, an external circuit is required, shown below.

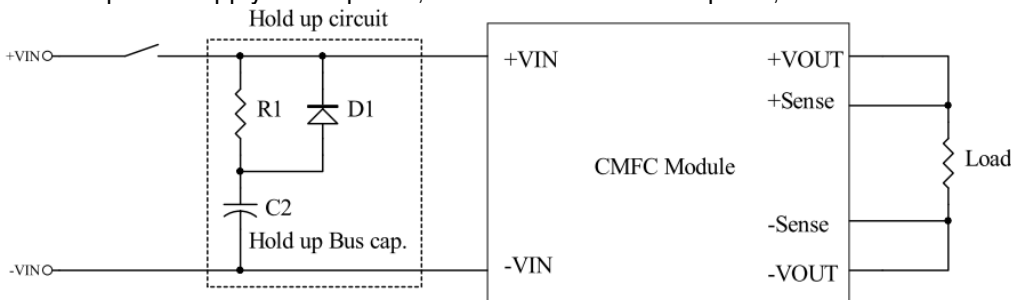

D1:200V/20A
R1:100Ω/10W

C2	72Vin	96Vin	110Vin
Hold up time for 10ms	3900uF	1900uF	1400uF
Hold up time for 30ms	12000uF	5600uF	4000uF



CHASSIS MOUNT CFB600W-110SXX-CMFD Series

Application Note V11 January 2019

7.7 Efficiency VS. Load

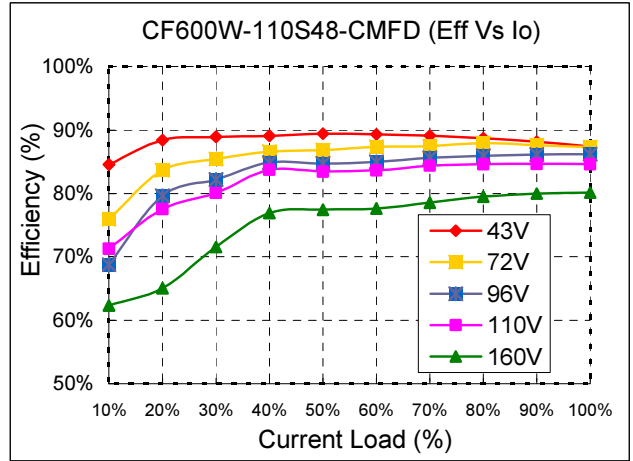
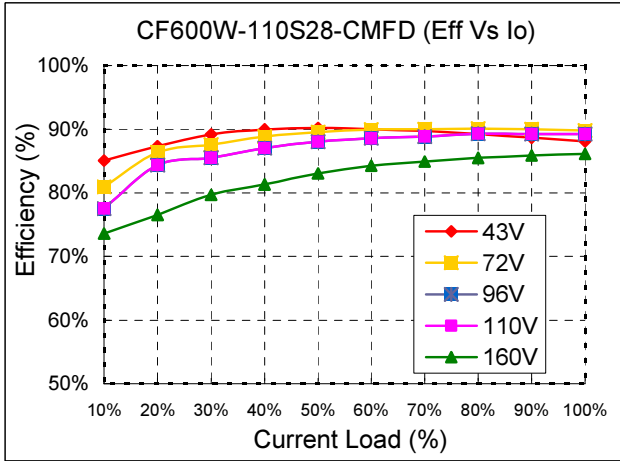
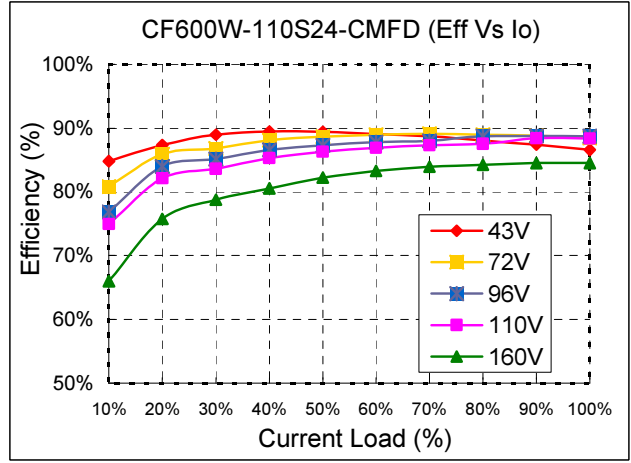
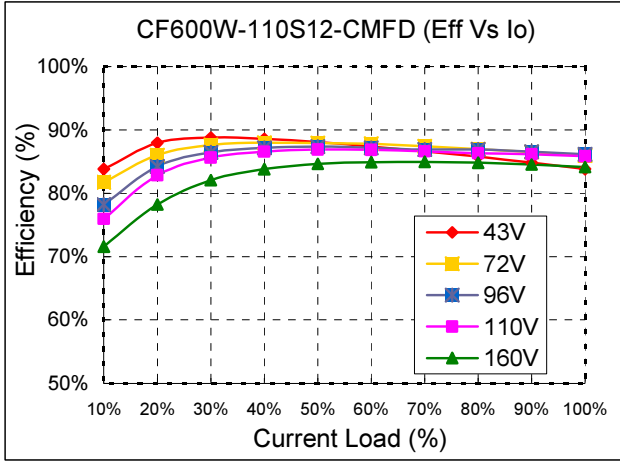



7.8 Test Set-Up

The basic test set-up to measure parameters such as efficiency and load regulation is shown below. When testing the modules under any transient conditions please ensure that the transient response of the source is sufficient to power the equipment under test. We can calculate:

- Efficiency
- Load regulation and line regulation.

The value of efficiency is defined as:

$$\eta = \frac{V_o \times I_o}{V_{in} \times I_{in}} \times 100\%$$

Where:

- V_o is output voltage,
- I_o is output current,
- V_{in} is input voltage,
- I_{in} is input current.

The value of load regulation is defined as:

$$Load.reg = \frac{V_{FL} - V_{NL}}{V_{NL}} \times 100\%$$

Where:

- V_{FL} is the output voltage at full load.
- V_{NL} is the output voltage at no load.

The value of line regulation is defined as:

$$Line.reg = \frac{V_{HL} - V_{LL}}{V_{LL}} \times 100\%$$

Where: V_{HL} is the output voltage of maximum input voltage at full load. V_{LL} is the output voltage of minimum input voltage at full load.

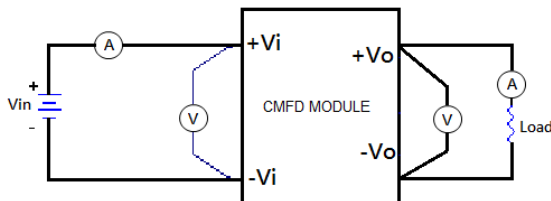

CFB600W-110SXX-CMFD Series Test Setup

7.9 Output Voltage Adjustment

7.9.1 Output Voltage Trim Range(±10%)

Output voltage(±10%) can be adjusted by internal variable resistor. Turning internal variable resistor clockwise reduces the output voltage and counterclockwise increases the output voltage.

counterclockwise clockwise



7.9.2 Output Voltage Trim Range(-40%, +10%)

Output may be externally trimmed ,need to remove jumpers on JP1 and JP2 and CN2 to reach the range of -40%~+10% output voltage. For details,please refer to CFB600W-110SXX series application note.

7.10 Output Remote Sensing

The CFB600W-110SXX-CMFD series converter has the capability to remotely sense both lines of its output. This feature moves the effective output voltage regulation point from the output of the unit to the point of connection of the remote sense pins. This feature automatically adjusts the real output voltage of the CFB600W-110SXX-CMFD series in order to compensate for voltage drops in distribution and maintain a regulated voltage at the point of load. The remote-sense voltage range is:

$$[(+V_{out}) - (-V_{out})] - [(+Sense) - (-Sense)] \leq 10\% \text{ of } V_{o_nominal}$$

When remote sensing is used, please remove the jumper of JP1&JP2. When remote sense is in use, the sense should be connected by twisted-pair wire or shield wire. If the sensing patterns short, heavy current flows and the pattern may be damaged. Output voltage might become unstable because of impedance of wiring and load condition when length of wire is exceeding 400mm. This is shown in the schematic below.

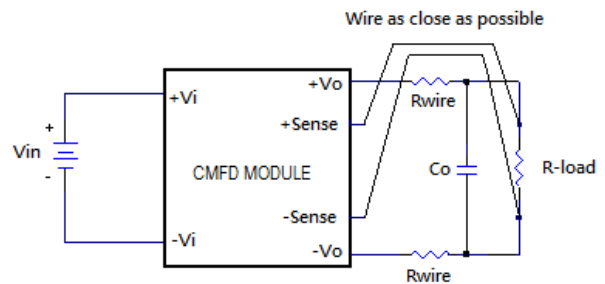

When the CMFD module are shipped from a factory, they come with a dedicated jumper being mounted on JP1&JP2. If the remote sense feature is not to be used, the sense pins should be connected locally. The +Sense pin should be connected to the +Vout pin at the module and the -Sense pin should be connected to the -Vout pin at the module. Wire between +Sense and +Vout and between -Sense and -Vout as short as possible. Loop wiring should be avoided. The converter might become unstable by noise coming from poor wiring. This is shown in the schematic below.



CHASSIS MOUNT CFB600W-110SXX-CMFD Series

Application Note V11 January 2019

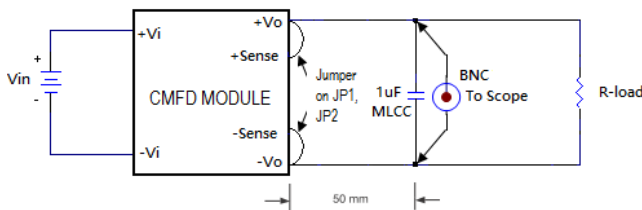

Note: Although the output voltage can be varied (increased or decreased) by both remote sense and trim, the maximum variation for the output voltage is the larger of the two values not the sum of the values. The output power delivered by the module is defined as the voltage at the output terminals multiplied by the output current. Using remote sense and trim can cause the output voltage to increase and consequently increase the power output of the module if output current remains unchanged. Always ensure that the output power of the module remains at or below the maximum rated power. Also be aware that if $V_{o,set}$ is below nominal value, $P_{out,max}$ will also decrease accordingly because $I_{o,max}$ is an absolute limit. Thus, $P_{out,max} = V_{o,set} \times I_{o,max}$ is also an absolute limit.

7.11 Output Ripple and Noise

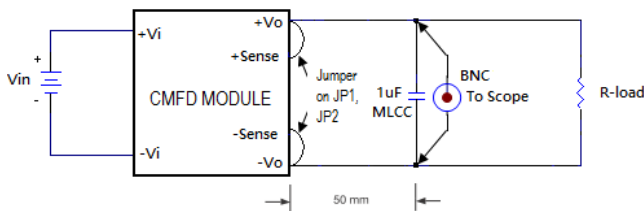

Output ripple and noise measured with 1uF ceramic capacitors across output. A 20 MHz bandwidth oscilloscope is normally used for the measurement.

The conventional ground clip on an oscilloscope probe should never be used in this kind of measurement. This clip, when placed in a field of radiated high frequency energy, acts as an antenna or inductive pickup loop, creating an extraneous voltage that is not part of the output noise of the converter.

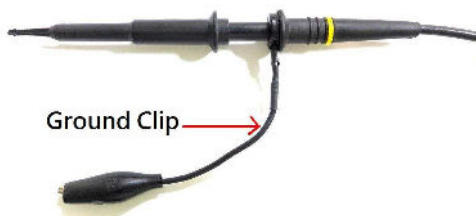

Another method is shown in below, in case of coaxial-cable/BNC is not available. The noise pickup is eliminated by pressing scope probe ground ring directly against the -Vout terminal while the tip contacts the +Vout terminal. This makes the shortest possible connection across the output terminals.

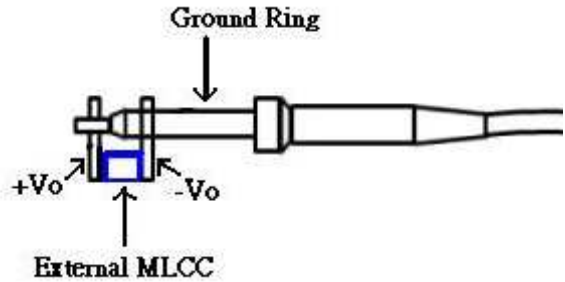

7.12 Output Capacitance

The CFB600W-110SXX-CMFD series converters provide unconditional stability with or without external capacitors. For good transient response, low ESR output capacitors should be located close to the point of load (<100mm). PCB design emphasizes low resistance and inductance tracks in consideration of high current applications. Output capacitors with their associated ESR values have an impact on loop stability and bandwidth. Cincon's converters are designed to work with load capacitance to see technical specifications.

7.13 Remote On/Off Circuit

The converter remote On/Off circuit built-in on input side. The ground pin of input side Remote On/Off circuit is -Vin pin. Refer to 6.5 for more details. Connection examples see below.

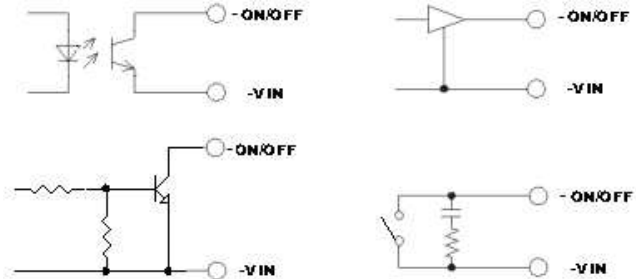

Remote On/Off Connection Example



8. Safety & EMC

8.1 Input Fusing and Safety Considerations

The CHB600W-110SXX-CMFD series converters have no internal fuse. In order to achieve maximum safety and system protection, always use an input line fuse. We recommended a 20A time delay fuse for all models. CHB600W-110SXX-CMFD module have a transient voltage suppressor diode (TVS) across the input terminal to protect the unit against surge or spike voltage and input reverse voltage (as shown).

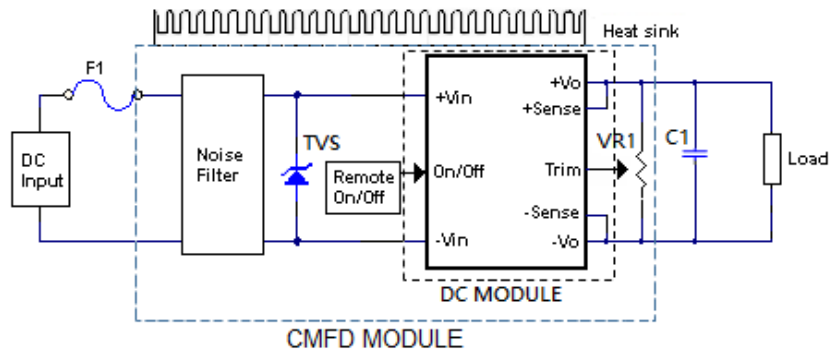

8.2 EMC Considerations

EMI Test standard: EN50121-3-2:2015 Conducted & Radiated Emission

Test Condition: Input Voltage: 110Vdc, Output Load: Full Load

(1) EMI meet EN50121-3-2:2015:

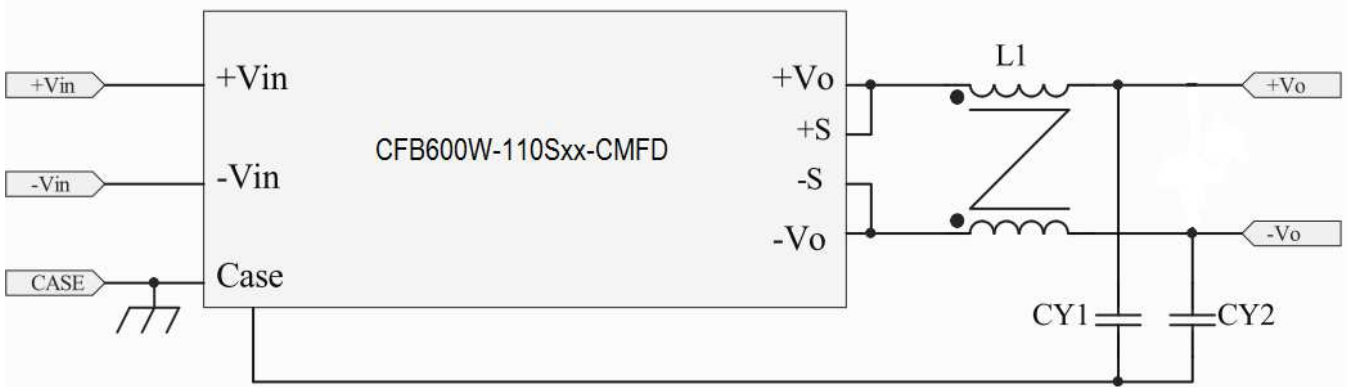

	Model number			
	110S12-CMFD	110S24-CMFD	110S28-CMFD	110S48-CMFD
CY1	10000pF/Y2	10000pF/Y2	10000pF/Y2	10000pF/Y2
CY2				
L1	FERROXCUBE T29/19/15-3E6 1.0mH, ϕ 1.0mm*3/9T	FERROXCUBE T29/19/15-3E6 1.0mH, ϕ 1.0mm*3/9T	FERROXCUBE T29/19/15-3E6 1.0mH, ϕ 1.0mm*3/9T	FERROXCUBE T29/19/15-3E6 2.2mH, ϕ 1.2mm*1/14T

Note: CYxx is MURATA Y2 capacitor or equivalent.



CHASSIS MOUNT CFB600W-110SXX-CMFD Series

Application Note V11 January 2019

Conducted Emission(Input):

CFB600W-110S12-CMFD

Line:

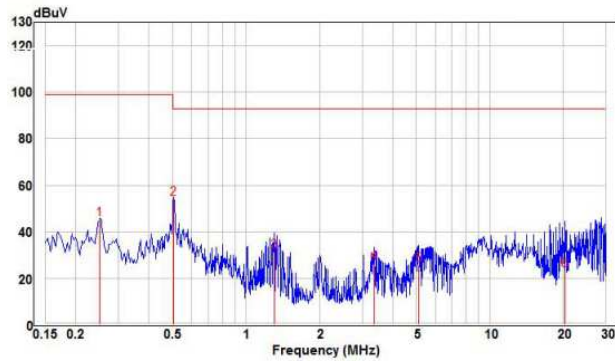

Neutral:

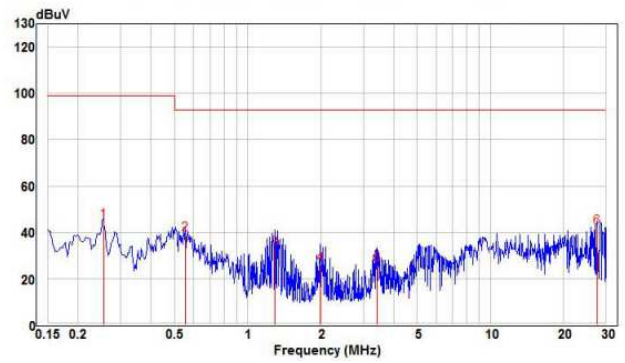

CFB600W-110S24-CMFD

Line:

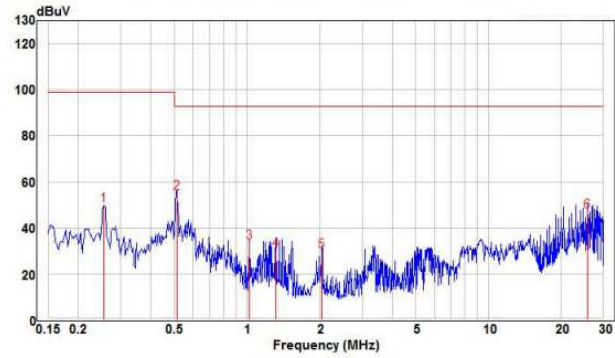

Neutral:

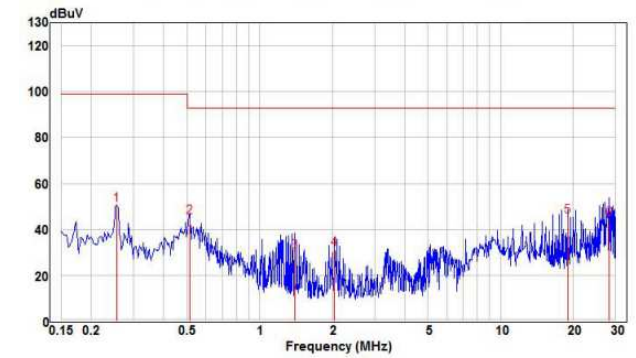

CFB600W-110S28-CMFD

Line:

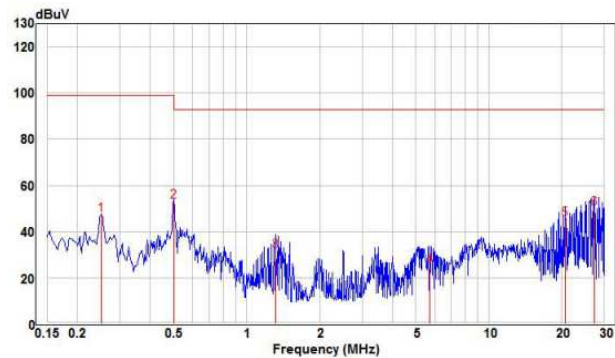

Neutral:

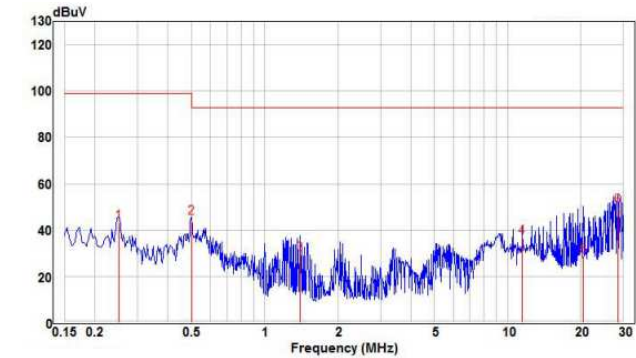

CFB600W-110S48-CMFD

Line:

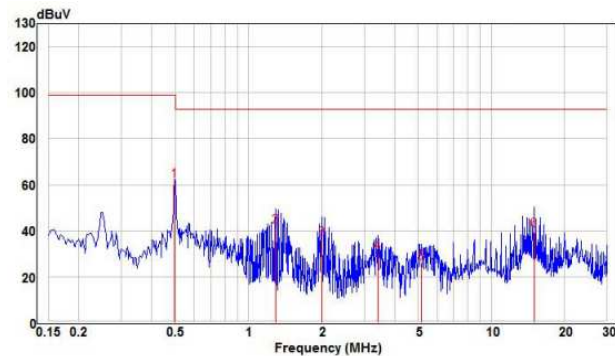

Neutral:

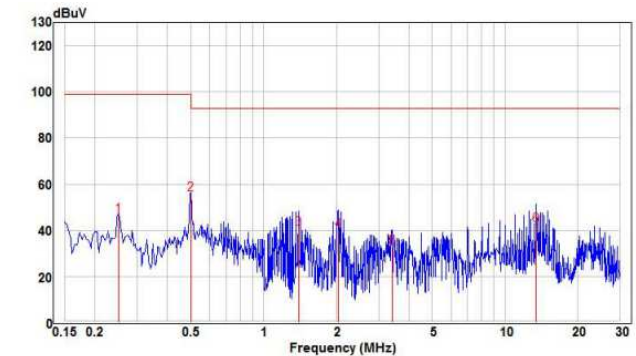



CHASSIS MOUNT CFB600W-110SXX-CMFD Series

Application Note V11 January 2019

Conducted Emission (Output):

CFB600W-110S12-CMFD (Positive)

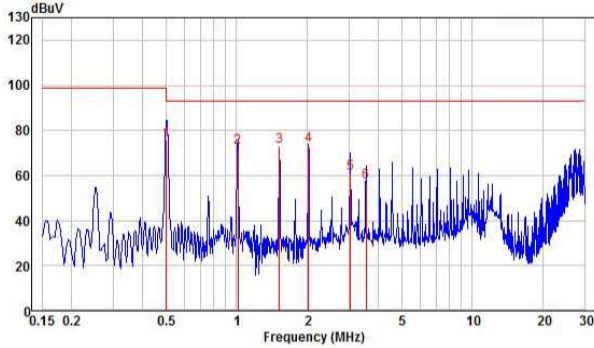

CFB600W-110S12-CMFD (Negative)

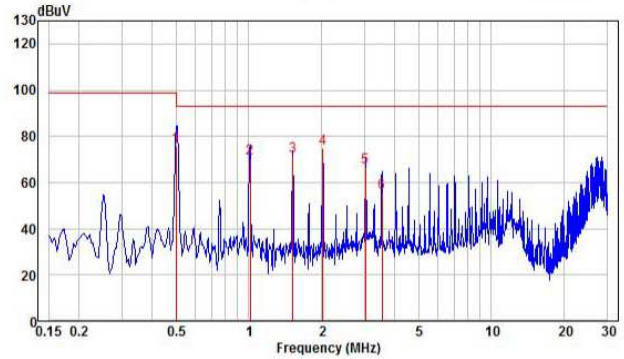

CFB600W-110S24-CMFD (Positive)

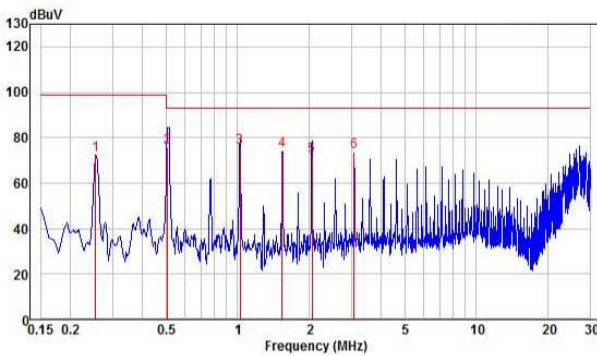

CFB600W-110S24-CMFD (Negative)

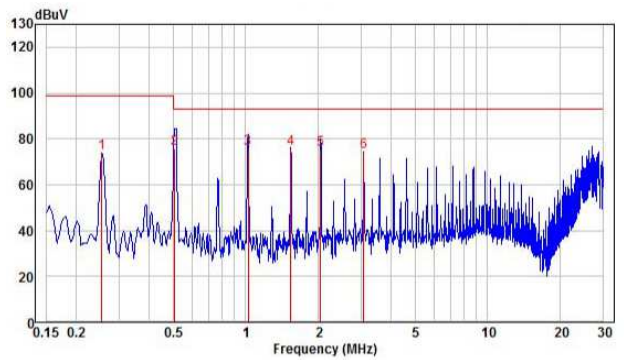

CFB600W-110S28-CMFD (Positive)

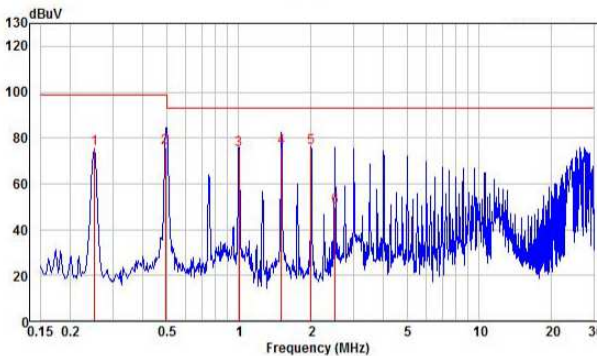

CFB600W-110S28-CMFD (Negative)

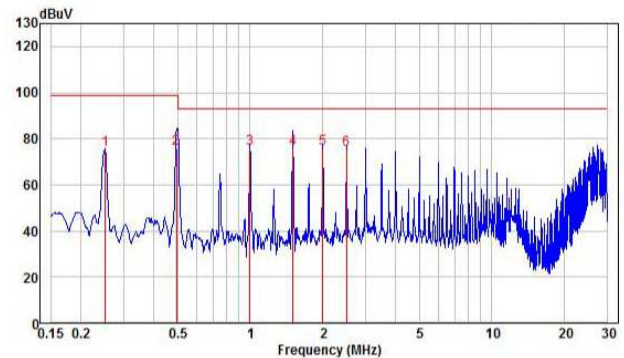

CFB600W-110S48-CMFD (Positive)

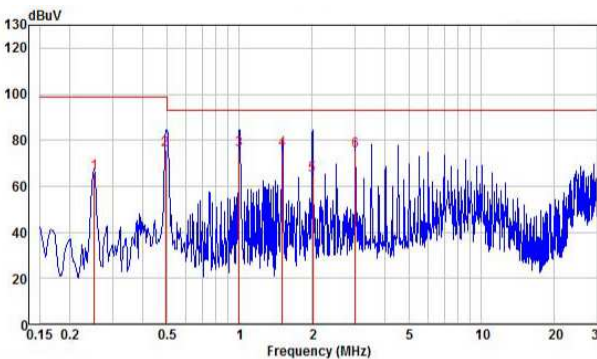

CFB600W-110S48-CMFD (Negative)

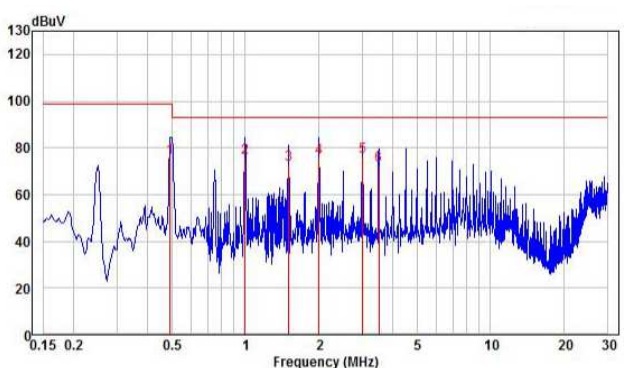



CHASSIS MOUNT CFB600W-110SXX-CMFD Series

Application Note V11 January 2019

Radiated Emission:

CFB600W-110S12-CMFD (Vertical)

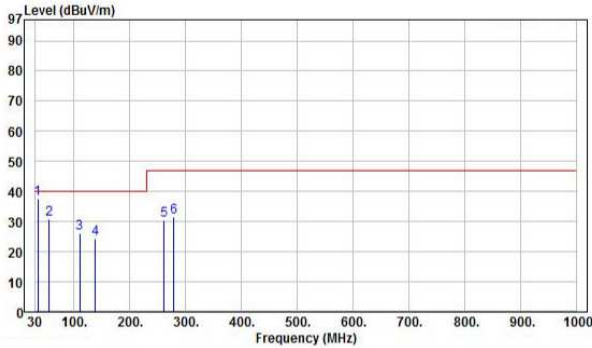

CFB600W-110S12-CMFD (Horizontal)

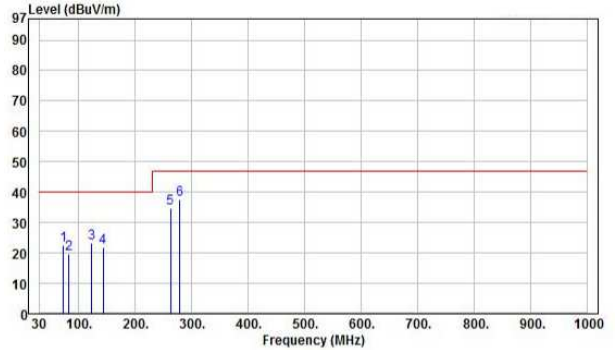

CFB600W-110S24-CMFD (Vertical)

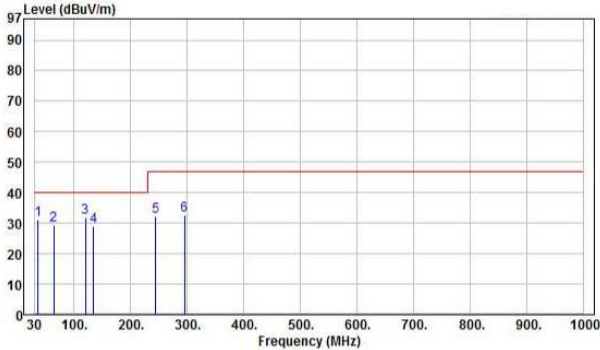

CFB600W-110S24-CMFD (Horizontal)

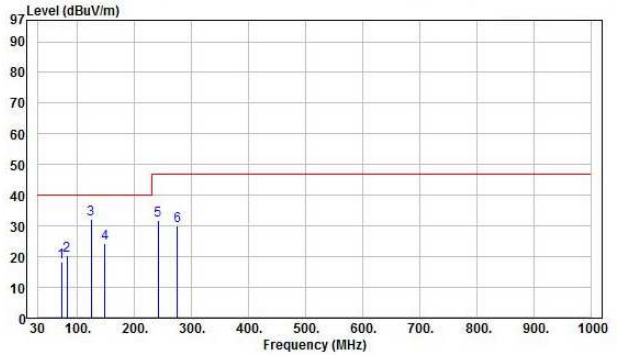

CFB600W-110S28-CMFD (Vertical)

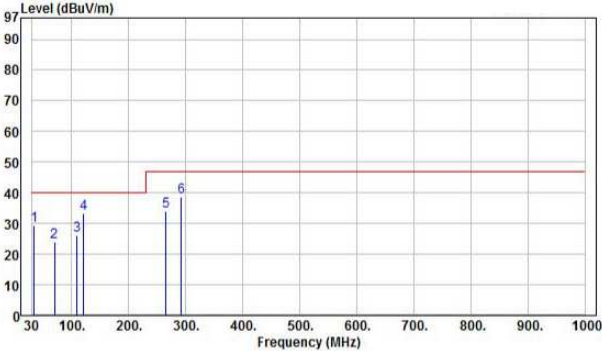

CFB600W-110S28-CMFD (Horizontal)

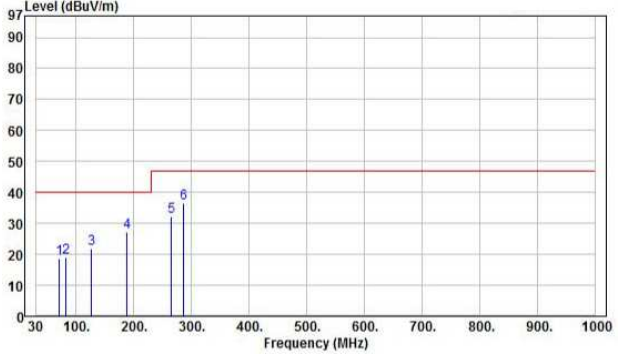

CFB600W-110S48-CMFD (Vertical)

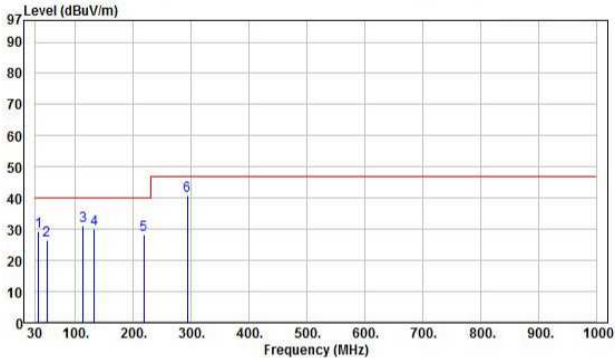

CFB600W-110S48-CMFD (Horizontal)

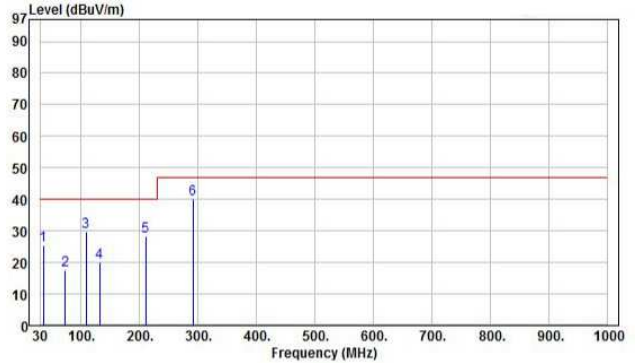



CHASSIS MOUNT CFB600W-110SXX-CMFD Series

Application Note V11 January 2019

9. Part Number

Format: CFB600W – III OXXL-YYYY

Parameter	Series	Nominal Input Voltage	Number of Outputs	Output Voltage	Remote On/Off Logic	Chassis Mount Type	
Symbol	CFB600W-	III	O	XX	L	YYY	Z
Value	CFB600W-	110: 110 Volts	S: Single	12: 12 Volts 24: 24 Volts 28: 28 Volts 48: 48 Volts	P: Positive None: Negative	CMF Chassis Mount Built in Filter	D with Cover

10. Mechanical Specifications

10.1 Mechanical Outline Diagrams

All Dimensions In Inches (mm)

Tolerance Inches: X.XX= ±0.02 , X.XXX= ±0.010

Millimeters: X.X= ±0.5 , X.XX=±0.25

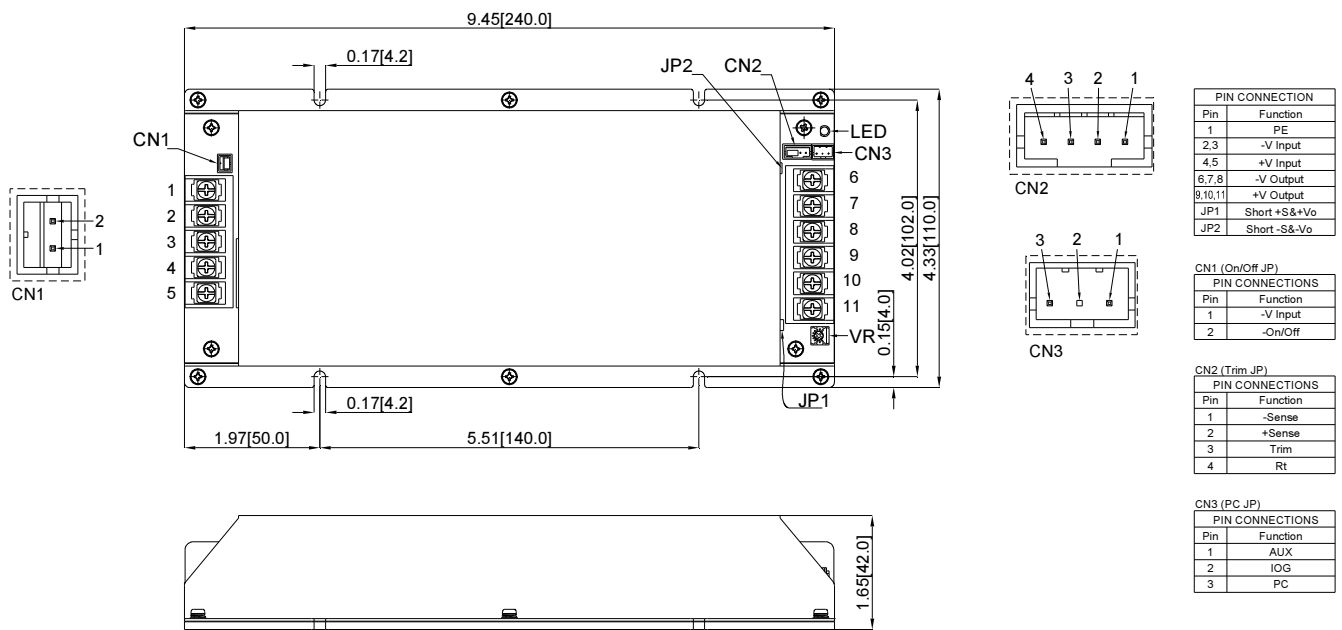

CFB600W-110SXX-CMFD Mechanical Outline Diagram

CINCON ELECTRONICS CO., LTD.

Headquarters:

14F, No.306, Sec.4, Hsin Yi Rd.
Taipei, Taiwan
Tel: 886-2-27086210
Fax: 886-2-27029852
E-mail: support@cincon.com.tw
Web Site: <http://www.cincon.com>

Factory:

No. 8-1, Fu Kung Rd.
Fu Hsing Industrial Park
Fu Hsing Hsiang,
ChangHua Hsien, Taiwan
Tel: 886-4-7690261
Fax: 886-4-7698031

Cincon North America:

1655Mesa Verde Ave. Ste 180
Ventura, CA93003
Tel: 805-639-3350
Fax: 805-639-4101
E-mail: info@cincon.com