



CFM400S Series

Application Note V10

400W AC-DC Power Supply with PFC CFM400S Series APPLICATION NOTE



Approved By:

Department	Approved By	Checked By	Written By
Research and Development Department	Ovid	Wei-Cheng	Horard
Design Quality Department	Benny	JoJo	



CFM400S Series

Application Note V10

Content

1. INTRODUCTION	3
2. ELECTRICAL BLOCK DIAGRAM	3
3. MAIN FEATURES AND FUNCTIONS	4
3.1 <i>Operating Temperature Range</i>	4
3.2 <i>Output Protection (Over Current Protection)</i>	4
4. APPLICATIONS	4
4.1 <i>Test Set-Up</i>	4
4.2 <i>Output Ripple and Noise Measurement</i>	4
4.3 <i>Installation Instruction</i>	5
4.4 <i>External Baseplate Cooling</i>	7
4.5 <i>PS On/Off Remote Control and Fan Control</i>	7
4.6 <i>Output Remote Sensing</i>	8
4.7 <i>EMI Test</i>	8
4.8 <i>Mating Connectors</i>	8
5. PACKING INFORMATION	9



CFM400S Series

Application Note V10

1. Introduction

This application note describes the features and functions of Cincon's CFM400S series of open frame, switching AC-DC power module. These are highly efficient, reliable, compact, high power density, single output AC/DC power modules. The module is fully protected against short circuit and over-voltage conditions. Cincon's world class automated manufacturing methods, together with an extensive testing and qualification program, ensure that the CFM400S series power module is extremely reliable.

2. Electrical Block Diagram

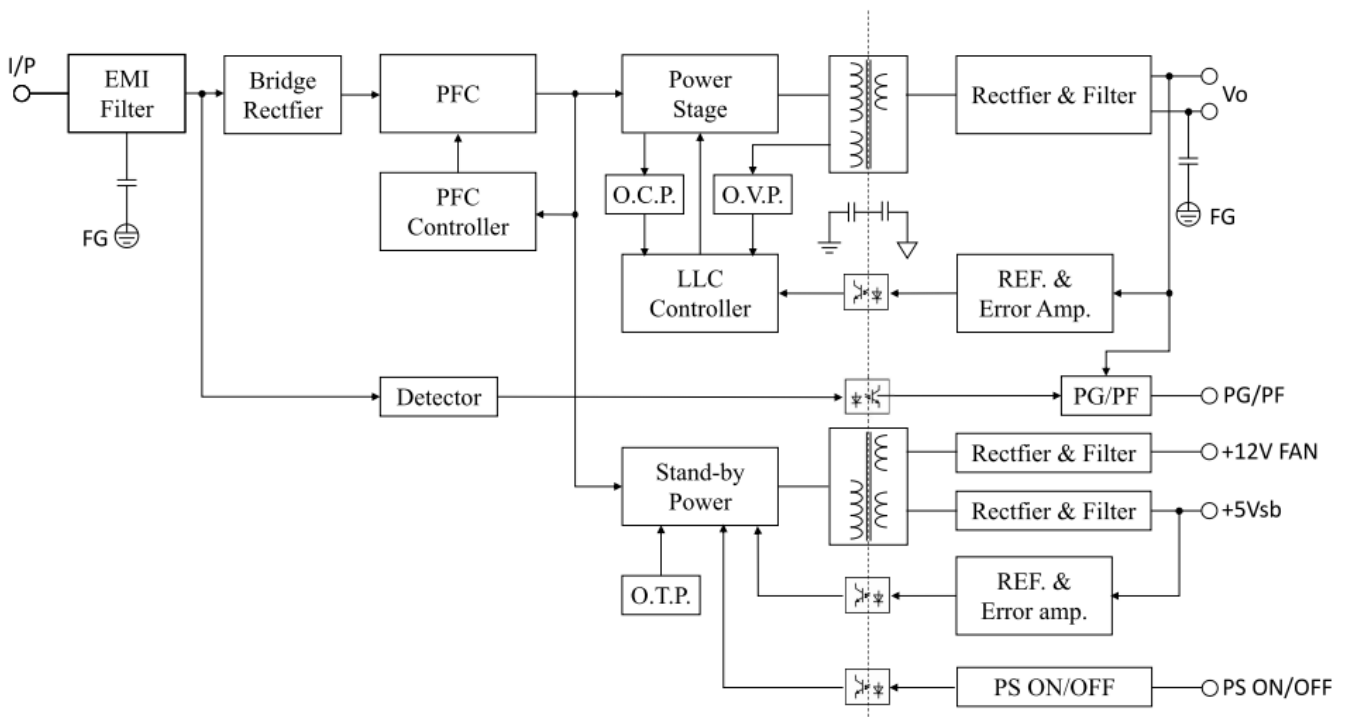



CFM400S Series

Application Note V10

3. Main Features and Functions

3.1 Operating Temperature Range

The highly efficient design of Cincon's CFM400S series power modules has resulted in their ability to operate within ambient temperature environments from -40°C to 85°C. Due consideration must be given to the de-rating curves when ascertaining the maximum power that can be drawn from the module. The maximum power which can be drawn is influenced by a number of factors, such as

- Input voltage range
- Permissible output load (per derating curve)
- Effective heat sinks

3.2 Output Protection (Over Current Protection)

The power modules provide full continuous short-circuit protection. The unit will auto recover once the short circuit is removed. To provide protection in a fault condition, the unit is equipped with internal over-current protection. The unit will operate normally once the fault condition is removed. The power module will go to hiccup mode if the output current is set from 110% to 190% of rated current.

4. Applications

4.1 Test Set-Up

The basic test set-up to measure parameters such as efficiency and load regulation is shown in Figure 1. When testing the Cincon's CFM400S series under any transient conditions, please ensure that the transient response of the source is sufficient to power the equipment under test. We can calculate the

- Efficiency
- Load regulation and line regulation

The value of efficiency is defined as:

$$\eta = \frac{V_o \times I_o}{P_{in}} \times 100\%$$

Where:

- Vo is output voltage
- Io is output current
- Pin is input power

The value of load regulation is defined as:

$$Load\ reg. = \frac{V_{FL} - V_{NL}}{V_{NL}} \times 100\%$$

Where:

- V_{FL} is the output voltage at full load
 - V_{NL} is the output voltage at 10% load
- The value of line regulation is defined as:

$$Line\ reg. = \frac{V_{HL} - V_{LL}}{V_{LL}} \times 100\%$$

Where:

- V_{HL} is the output voltage of maximum input voltage at full load.
- V_{LL} is the output voltage of minimum input voltage at full load.

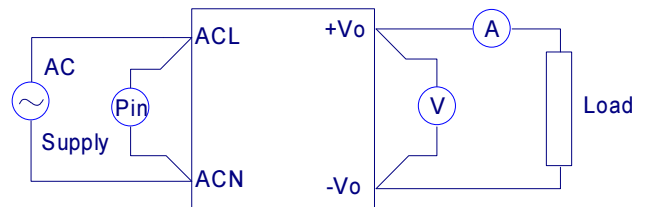

Figure 1. CFM400S Series Test Setup

4.2 Output Ripple and Noise Measurement

The test set-up for noise and ripple measurements is shown in Figure 2. Measured method: Add a C1=0.1uF ceramic capacitor and a C2=10uF electrolytic capacitor to output at 20 MHz Band Width.

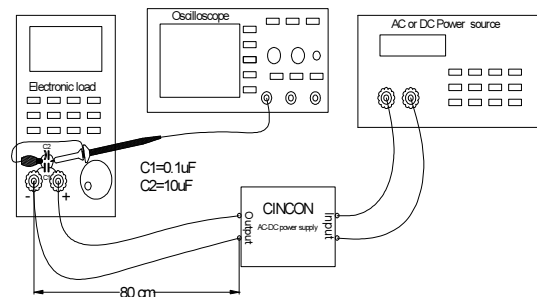

Figure 2. Output Voltage Ripple and Noise Measurement Set-Up



CFM400S Series

Application Note V10

4.3 Installation Instruction

The CFM400S series has four 4mm diameter mounting holes. There are three type installations for CFM400S. Please use the mounting holes as follows: Insert the spacer (4mm diameter max.) of 8mm height or more to mount the unit.

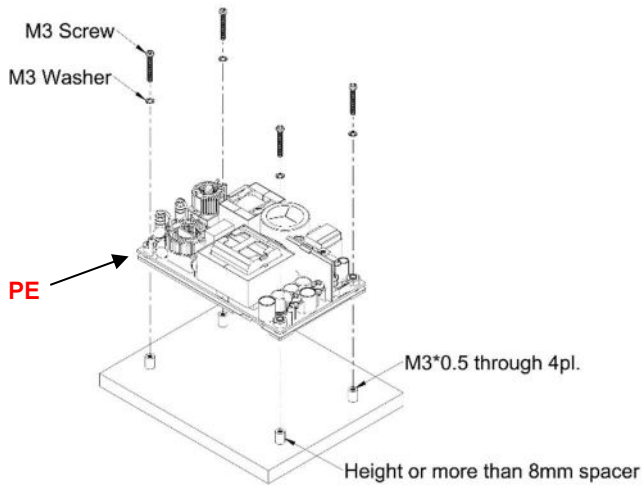

CFM400SXXX Installation Diagram

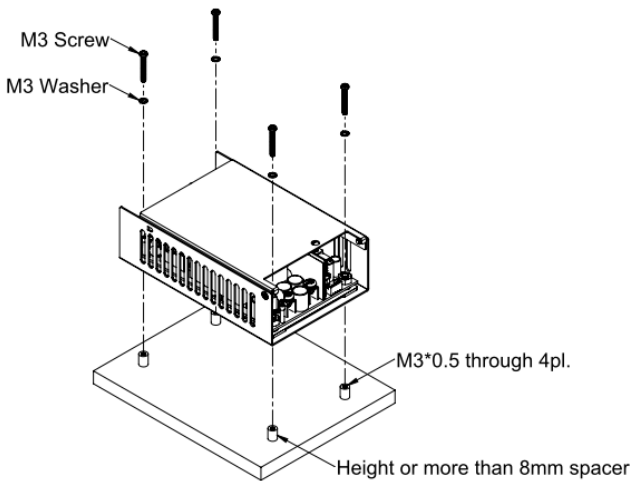

CFM400SXXXC Installation Diagram

The CFM400S series provide the baseplate cooling for customer to increasing heat dissipation. Please refer to the following figure for installation.

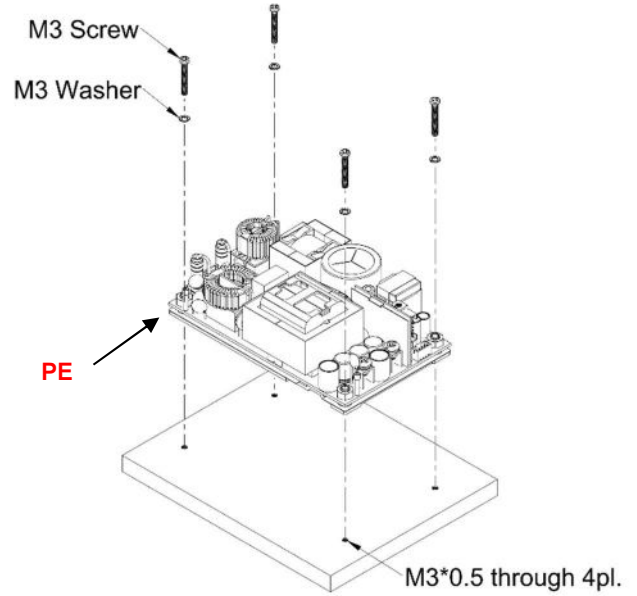

CFM400SXXXC installation diagram

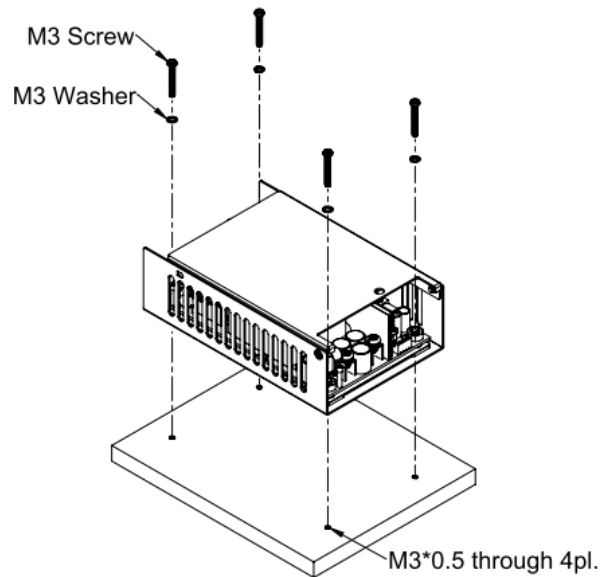

CFM400SXXXC installation diagram



CFM400S Series

Application Note V10

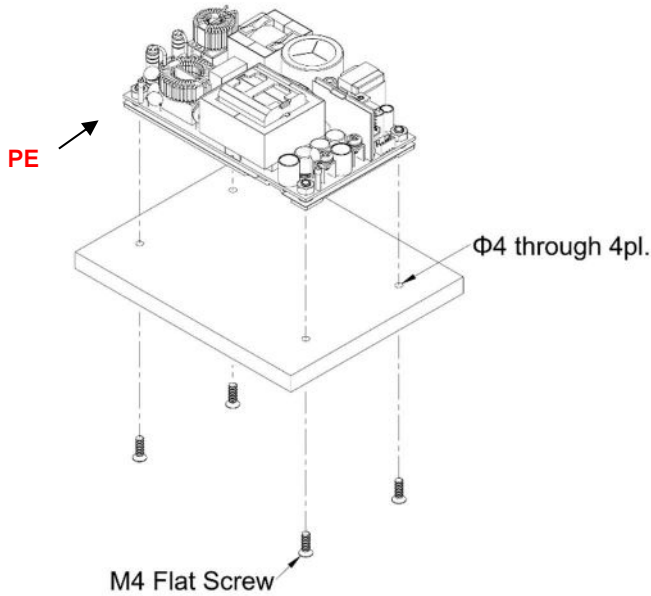

CFM400SXXX installation diagram

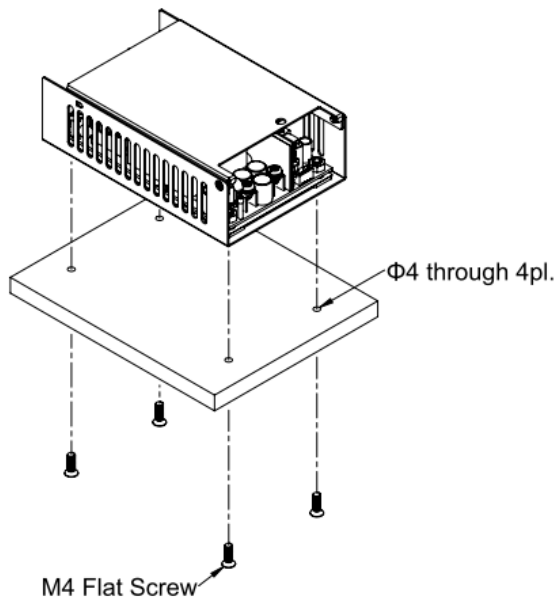

CFM400SXXXC installation diagram

Note: M3 & M4 screw head and washer diameter shall not exceed 5.5mm.

The torque of CFM400S series as follows:

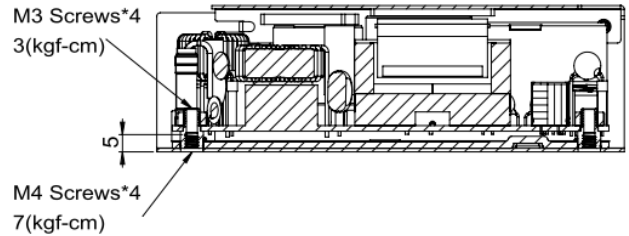
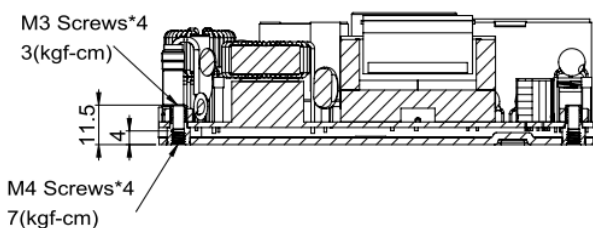

The torque of output connectors are 7kgf-cm and the connectors mate with round terminal. The maximum outer diameter of the terminal is 8.0mm and the maximum inner diameter is 4.3mm. When locking the round terminal or Y terminal to output connectors, the terminals should not touch other parts to avoid short.

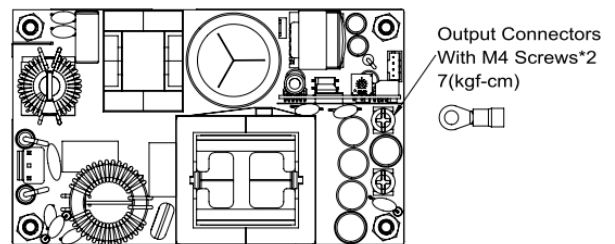

Please allow 4mm side clearance from the components and all side of the PCB. Allow 5mm clearance above the highest parts on the PCB. Be especially careful to allow 5mm between the solder side of the PCB and the mounting surface. If the clearances are not sufficient the specifications for isolation and withstand will not be valid.

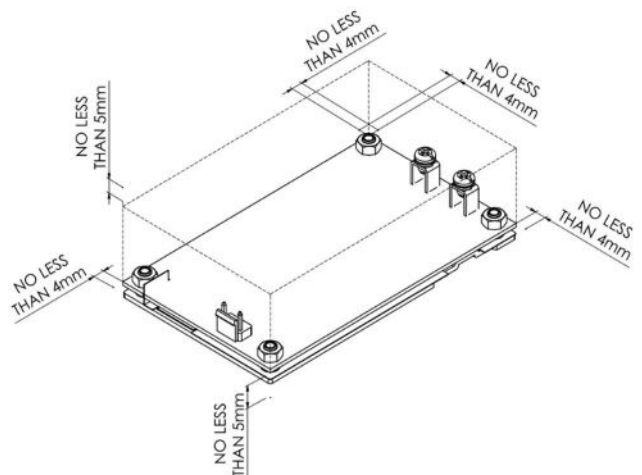

FG should be connected to the earth (ground) terminal of the apparatus. If not the conducted noise and output noise will increase.



CFM400S Series

Application Note V10

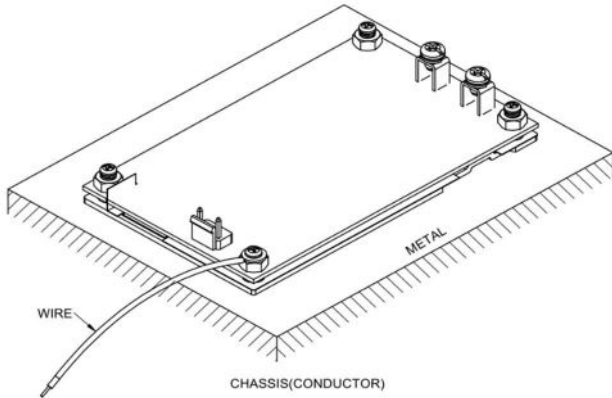

4.4 External Baseplate Cooling

The CFM400S series provide the baseplate cooling for customer to increasing heat dissipation. For example, adding a 480mm*248mm*1.2mm heatsink at the bottom of CFM400S, between the heatsink and CFM400S with thermal grease to help heating ability. Please refer to the following figure for installation. When the CFM400S series uses an external baseplate cooling solution, it can be used at 280~400W. Please refer to the power derating curve in the specification.

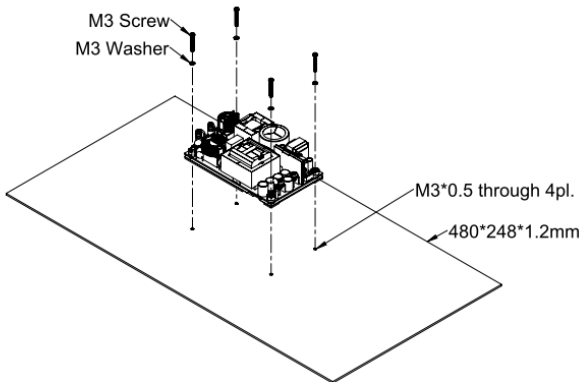

CFM400SXXX installation diagram

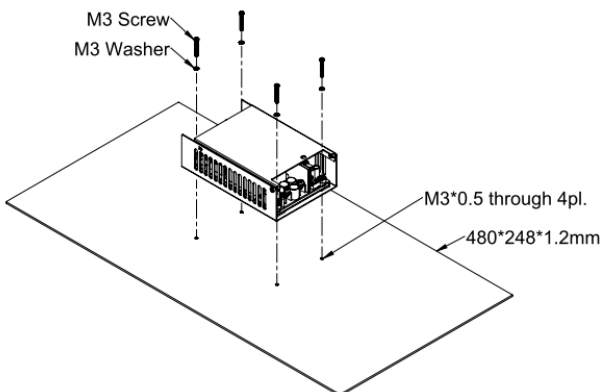

CFM400SXXXC installation diagram

4.5 PS On/Off Remote Control and Fan Control

The PS-ON remote control is provided in CN3 pin 4. The diagram and control function are shown as follow:

Power On: $V_{PS-ON} \leq 2V$, $I_{PS-ON} \geq 10mA$ (PS-ON and GND short, $I_{PS-ON} = 10mA$ typical)
 Power Off: Open circuit, $V_{PS-ON} = 4V$

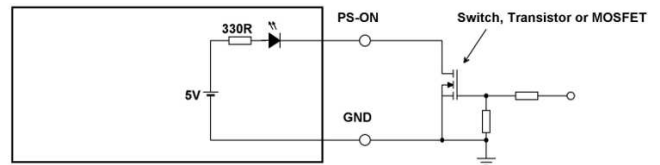

The fan control is provided in CN3 pin 3. The control function and diagram are shown as follow:

Fan On: $V_{FAN-EN} \geq 1V$
 Fan Off: Open circuit, $V_{FAN-EN} = 0V$

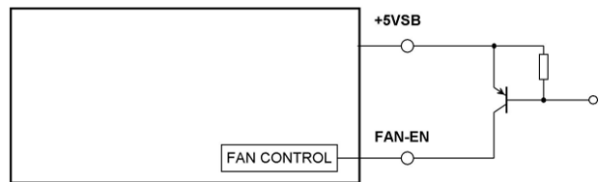

When the PS On/Off remote-control function is not used, connect a short circuit between the pin PS-ON and FAN-EN.

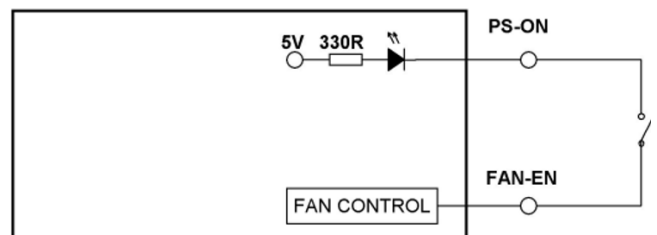



CFM400S Series

Application Note V10

4.6 Output Remote Sensing

The CFM400S SERIES converter has the capability to remotely sense both lines of its output. This feature moves the effective output voltage regulation point from the output of the unit to the point of connection of the remote sense pins. This feature automatically adjusts the real output voltage of the CFM400S series in order to compensate for voltage drops in distribution and maintain a regulated voltage at the point of load. The remote-sense voltage range is:

$$[(+V_{out}) - (-V_{out})] - [(+Sense) - (-Sense)] \leq 5\% \text{ of } V_{o_nominal}$$

If the remote sense feature is not to be used, the sense pins should be connected locally. The +Sense pin should be connected to the +Vout pin at the module and the -Sense pin should be connected to the -Vout pin at the module. A Remote Sensing is provided in CN3. This is shown in the schematic as below.

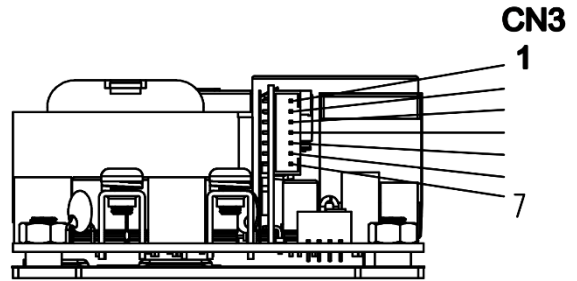
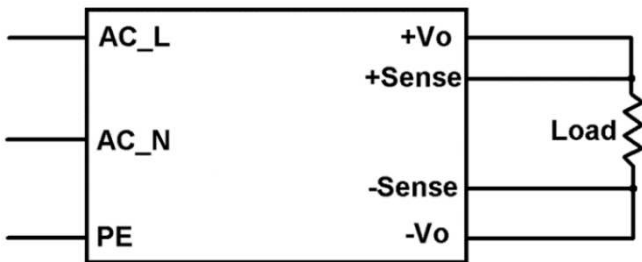

CN1: Input connector wafer with JST VH series and mate with JST housing VHR series or equivalent. Optional Input connector wafer with LONG CHU P3161 series and mate with LONG CHU H3060 series or equivalent.

CN2: Output connector wafer with TAIWAN KING PIN TERMINAL P110I series and mate with JST housing PH series or equivalent.

CN3: Output connector wafer with JST PH series and mate with JST housing PH series or equivalent.

V_{o+} & V_{o-}: Output connectors mate with round terminal and round terminal of the max outer diameter is 8.0mm, max inner diameter is 4.3mm.

4.7 EMI Test

The CFM400S series Conductive EMI meets EN55032, FCC Part 15 Class B when test condition is Class I.

4.8 Mating Connectors

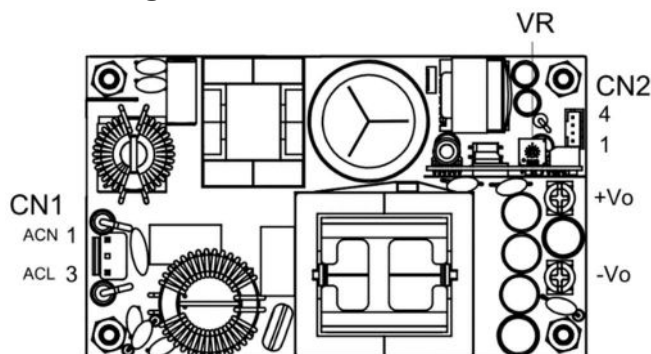



CFM400S Series

Application Note V10

5. Packing Information

The packing information for CFM400SXXX is showing as follows:

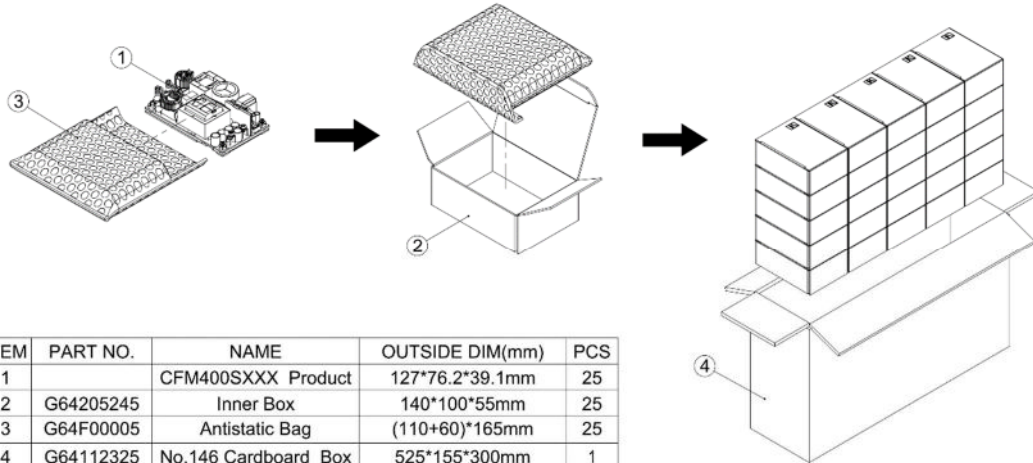

ITEM	PART NO.	NAME	OUTSIDE DIM(mm)	PCS
1		CFM400SXXX Product	127*76.2*39.1mm	25
2	G64205245	Inner Box	140*100*55mm	25
3	G64F00005	Antistatic Bag	(110+60)*165mm	25
4	G64112325	No.146 Cardboard Box	525*155*300mm	1

Each Box Packaging 25 PCS Products
Gross weight Ref. 14.5 Kg

The packing information for CFM400SXXXC is showing as follows:

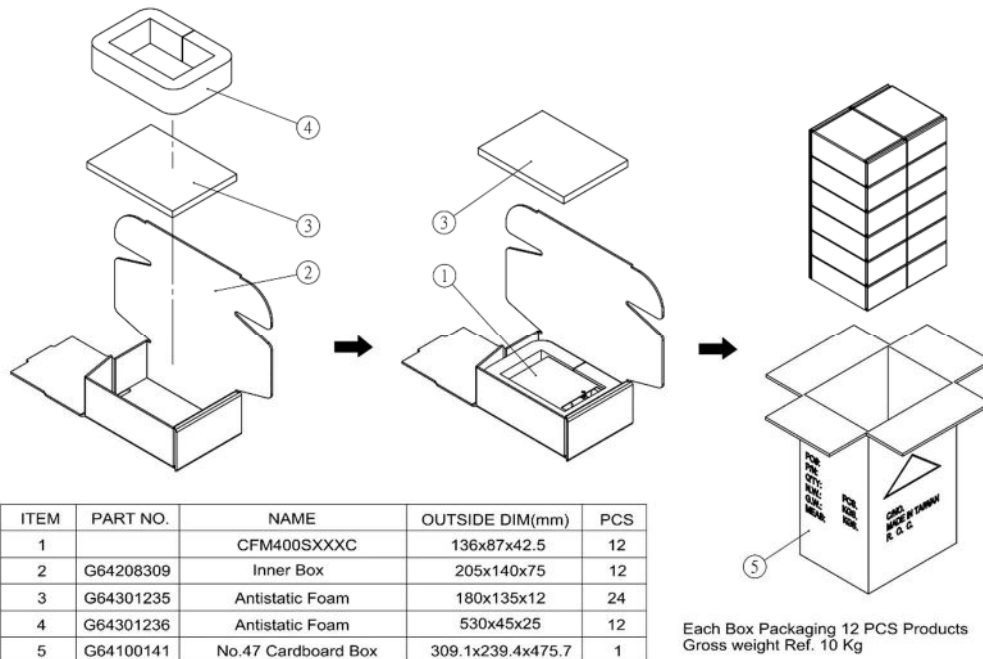

ITEM	PART NO.	NAME	OUTSIDE DIM(mm)	PCS
1		CFM400SXXXC	136x87x42.5	12
2	G64208309	Inner Box	205x140x75	12
3	G64301235	Antistatic Foam	180x135x12	24
4	G64301236	Antistatic Foam	530x45x25	12
5	G64100141	No.47 Cardboard Box	309.1x239.4x475.7	1

Each Box Packaging 12 PCS Products
Gross weight Ref. 10 Kg

CINCON ELECTRONICS CO., LTD.

Headquarters:

14F, No.306, Sec.4, Hsin Yi Rd.
Taipei, Taiwan
Tel: 886-2-27086210
Fax: 886-2-27029852
E-mail: sales@cincon.com.tw
Web Site: <http://www.cincon.com>

Factory:

No. 8-1, Fu Kung Rd.
Fu Hsing Industrial Park
Fu Hsing Hsiang,
Chang Hua Hsien, Taiwan
Tel: 886-4-7690261
Fax: 886-4-7698031

Cincon North America:

1655 Mesa Verde Ave. Ste 180
Ventura, CA 93003
Tel: 805-639-3350
Fax: 805-639-4101
E-mail: info@cincon.com