

OPS-260

IP66 180...220W 260VA DC/AC SINE WAVE INVERTER

GENERAL FEATURES:

- Sine wave output voltage
- Selectable output frequency: 50/60Hz
- Convection cooling
- IP66 protection
- Output failure alarm
- Remote inhibit
- High input-output isolation 3000Vrms
- Optional railway version EN50155
- Fire and smoke: EN45545-2 approved
- OCS-260 inside



	12Vdc 9.5 ... 15V ⁽¹⁾	24Vdc 16.8 ... 30V	36Vdc 25.2 ... 45V	48Vdc 33.6 ... 60V	72Vdc 50.4 ... 90V	110Vdc 77 ... 138V
120Vac	OPS-260-7741* 180W	OPS-260-7743* 200W	OPS-260-7744* 220W	OPS-260-7745* 220W	OPS-260-7746* 220W	OPS-260-7747* 220W
230Vac	OPS-260-7731* 180W	OPS-260-7733* 200W	OPS-260-7734* 220W	OPS-260-7735* 220W	OPS-260-7736* 220W	OPS-260-7737* 220W

*References subject to special MOQs and lead times

Note ⁽¹⁾: Startup voltage $\leq 10.2V$. Under-voltage shutdown $\leq 9.1V$



INPUT	
Input voltage range	See table
Maximum input ripple	5% Vin nom (Vrms, 100Hz)
OUTPUT	
Nominal output voltage (Vonom)	See table
Adjust range	± 5% of Vonom
Load regulation	4%
Line regulation	0.4% @ ΔVin -20...+25% 10% @ ΔVin -30...+25% 1% @ ΔVin -10...+25% for 12V input models 10% @ ΔVin -20...+25% for 12V input models
Output frequency	50 / 60Hz ± 0.25Hz (factory set)
Output wave distortion THD	< 2% (16 samples average)
Output voltage HF ripple	< 20Vpp for 230Vac models < 10Vpp for 120Vac models
ENVIRONMENTAL	
Storage temperature	-40 ... 80°C
Operating temperature (full load)	-40 ... 55°C
Operating temperature (62.5% load)	-40 ... 70°C
Cooling	Natural convection
MTBF (MIL-HDBK-217-E; G _b , 25°C)	250.000 h
EMC	
Immunity according	EN61000-6-2 EN50121-3-2
Emissions according	EN61000-6-3 EN50121-3-2
SAFETY	
Safety according to	EN60950-1, EN62368-1 Class I OV category II, Pollution degree 2 Input / output isolation: reinforced
Dielectric strength: Input /output	3000 Vrms / 50Hz / 1min (routine test 2s)
Dielectric strength: Output / ground	1500 Vrms / 50Hz / 1min (routine test 2s)
Dielectric strength: Input / ground	500 Vrms / 50Hz / 1min (routine test 2s)
Fire and smoke	EN45545-2
IP Grade	IP66
MECHANICAL	
Weight	1.74 Kg
Dimensions	67 x 249 x 135mm
PROTECTIONS	
Against input over-currents	Internal fuse
Against output overloads < I _{ompk}	linear
Against output overloads > I _{ompk}	Triggered
CONTROL	
Remote inhibit input	4 ... 24 Vdc
Output failure alarm	Solid state relay, open when alarm. Max: 60V, 0.3A



ORDERING CODES

Model	Input Voltage DC [V]	Input voltage range [V]	Max. Input Current [A]	Output voltage AC [V]	Output current [A]	Active output power [W]	Appar. output power [VA]	Output Peak curr. 10ms [A]	Efficiency [%]	No load input current [A]
OPS-260-7731*	12	9.50 - 15	22.1	230	0.78	180	260	4.0	86	0.50
OPS-260-7733*	24	16.8 - 30	13.7	230	0.87	200	260	4.0	87	0.26
OPS-260-7734*	36	25.0 - 45	10.0	230	0.96	220	260	4.0	88	0.21
OPS-260-7735*	48	33.6 - 60	7.36	230	0.96	220	260	4.0	89	0.15
OPS-260-7736*	72	50.4 - 90	4.91	230	0.96	220	260	4.0	89	0.11
OPS-260-7737*	110	77 - 138	3.17	230	0.96	220	260	4.0	90	0.08
OPS-260-7741*	12	9.50 - 15	22.3	120	1.50	180	260	7.6	85	0.50
OPS-260-7743*	24	16,8 - 30	13.7	120	1.67	200	260	7.6	87	0.26
OPS-260-7744*	36	25.0 - 45	10.0	120	1,83	220	260	7.6	88	0.21
OPS-260-7745*	48	33.6 - 60	7.45	120	1,83	220	260	7.6	88	0.15
OPS-260-7746	72	50.4 - 90	4.97	120	1,83	220	260	7.6	88	0.11
OPS-260-7747*	110	77 - 138	3.22	120	1,83	220	260	7.6	89	0.08

* References subject to special MOQs and lead times

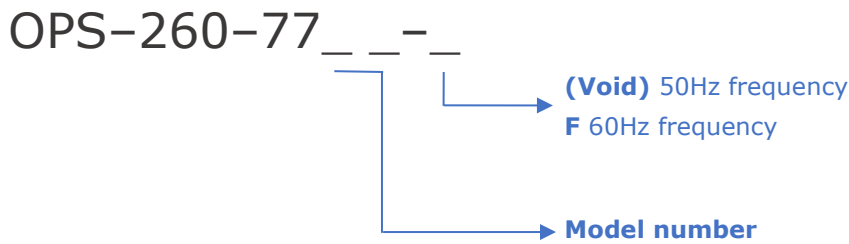

Specify in/out combination to confirm part number.

BLOCKS DIAGRAM

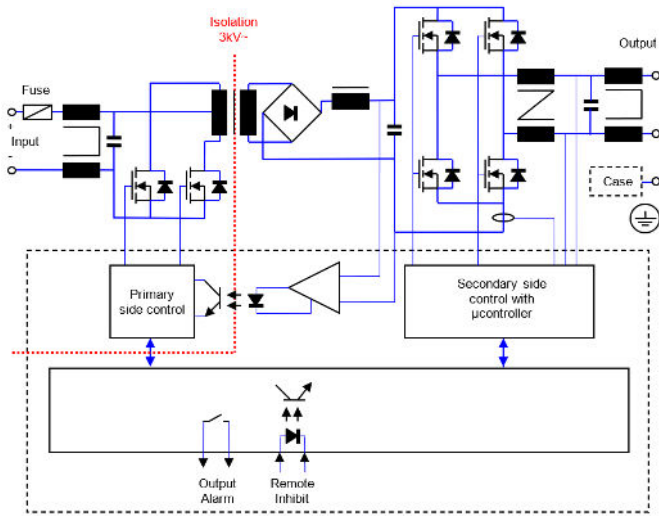

DESCRIPTION

The OPS-260 consists of sine-wave 120Vac or 230Vac output voltage DC-AC converters. The frequency can be factory selected to 50Hz or 60 Hz, and input and output are galvanically isolated.

The OPS-260 inverters consist of two cascaded converters, one DC-DC generating an intermediate output voltage from the input voltage. That intermediate voltage is inverted to supply the output voltage and frequency by means of a second DC/AC converter.

The input is protected against reverse polarity by means of fuse and against under-voltage by unit shutdown.

The output has protection of maximum average power and maximum peak current. The unit shutdowns when the operation curve limit is exceeded for more than one second. Every 2 seconds after shutdown, the unit tries to restart up to 3 times. If the overload persists, the unit remains shutdown until an input reconnection.

CONNECTIONS

IP67 rated connector:

Connector	Manufacturer / Model	PIN	Reference
J1	 MOLEX MX150 L Series 194270017	1	N Output
		2	+ Alarm
		3	+ Inhibit
		4	+ V Input
		5	L Output
		6	- Alarm
		7	- Inhibit
		8	- V Input

Remark: the product is supplied without the mating connectors.

OPERATION CURVE LIMITS

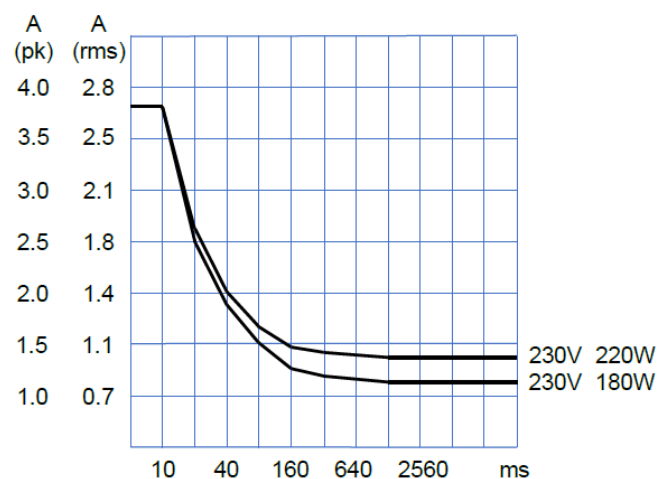
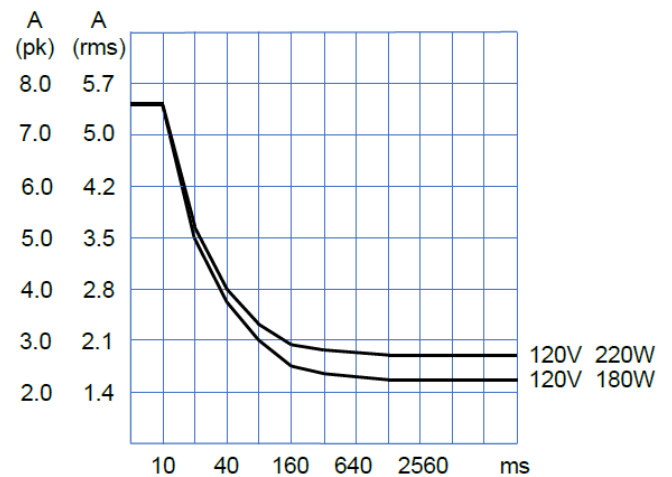



POWER DERATING vs AMBIENT TEMPERATURE

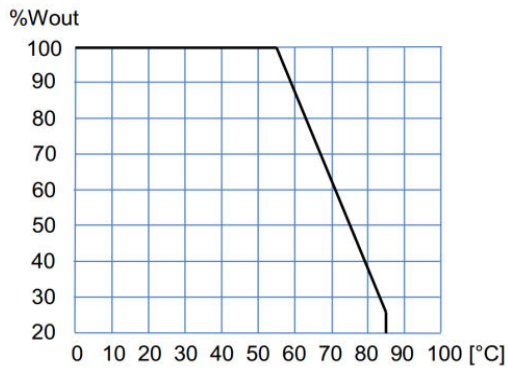

RECOMMENDED WIRING

	Input 12V	Input 24V	Input 36V	Input 48V	Input 72V	Input 110V	Output 120Vca	Output 230Vca
Max. Current [A]	23	14	10	7.4	5.0	3.2	2.2	1.2
Cable Section [mm ²]	2.5	1.5	1.5	1	0.75	0.75	0.75	0.75

INSTALLATION

The product can be mounted in several ways:

- On a chassis by means of the 4 corner holes.

Make connections as shown in the CONNECTIONS table.

The inverter includes active overload protection but does not provide protection against prolonged reactive overload conditions. Therefore, the maximum power output (VA) should not be exceeded.

For safety reasons, the following requirements must be met:

- Provide the equipment with some kind of protective enclosure that complies with the electrical safety directives in effect within the country where the equipment is installed.
- Use cables of adequate cross-section to connect inputs and outputs. The following table lists the maximum currents and the minimum cross-sections for the cables used for each power connection.

DIMENSIONS

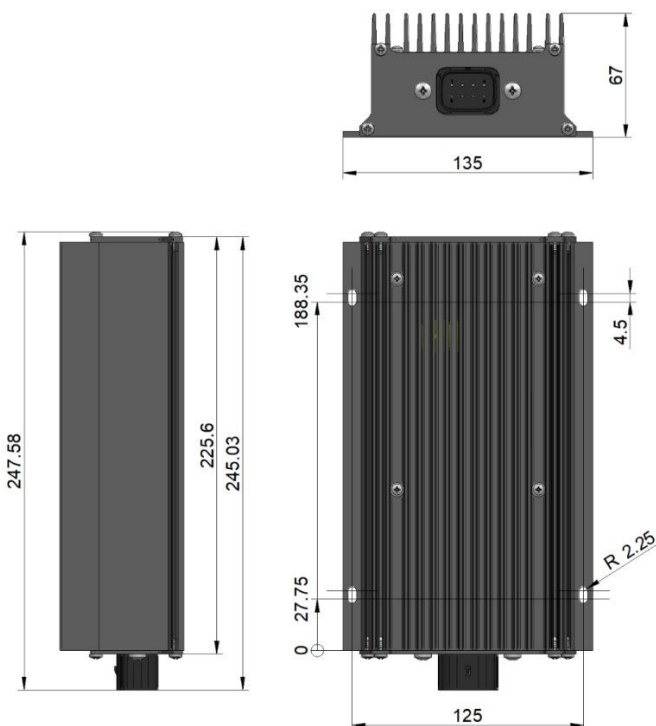



CE EU DECLARATION OF CONFORMITY

The undersigned, representing the following:

Manufacturer: PREMIUM, S. A.,
Address: C/. Dolors Aleu 19-21, 08908 L'Hospitalet de Llobregat, SPAIN

herewith declares that the product:

Type: DC/AC Inverter
Models: **OPS-260-7731 ... 7747**

is in conformity with the provisions of the following EU directive(s):

2014/35/EU	Low voltage
2014/30/EU	Electromagnetic compatibility
2011/65/EU	Restriction of the use of certain hazardous substances in electrical and electronic equipment (RoHS)

and that standards and/or technical specifications referenced below have been applied:

EN 60950: 2005	Safety (Information technology equipment)
EN 62368-1: 2014	Safety. Audio/video, information and communication technology equipment
EN 61000-6-3: 2007	Generic emission standard
EN 61000-6-2: 2005	Generic Immunity standard
EN 50155: 2017*	Railway applications. Electronic equipment used on rolling stock material
EN 50121-3-2: 2016*	Railway applications. EMC Rolling stock equipment

* Optional, see annexe

CE marking year: **2021**

Notes:

For the fulfilment of this declaration the product must be used only for the aim that has been conceived, considering the limitations established in the instructions manual or datasheet.

L'Hospitalet de Llobregat, 05-02-2021

Albert Solé
Technical Director

PREMIUM S.A. is an ISO9001 and ISO14001
certified company by **Bureau Veritas**

ANNEXE

Applicable values for the different sections of the norm EN50155: 2017																																																																								
4.3.1	Working altitude	Up to 1800m																																																																						
4.3.2	Ambient temperature	Class OT1 (-25 to 55°C): load < 100% Class OT2 (-40 to 55°C): load < 100% (Without connectors handling) Class OT3 (-25 to 70°C): load < 50% Class OT4 (-40 to 70°C): load < 50% (Without Connectors handling)																																																																						
4.3.3	Switch-on extended operating temp.	ST1																																																																						
4.3.4	Rapid temperature variations	H1																																																																						
4.3.5	Shocks and vibrations	According EN61373:2010 Category 1 class B																																																																						
4.3.6	EMC Electromagnetic Compatibility EN50121-3-2:2016	<table border="1"> <thead> <tr> <th>Test</th> <th>Norm</th> <th>Port</th> <th>Frequency</th> <th>Limits</th> </tr> </thead> <tbody> <tr> <td rowspan="3">Radiated emissions</td> <td rowspan="3">IEC55016</td> <td rowspan="3">Case</td> <td>30MHz...230MHz</td> <td>40dB(μV/m) Qpk at 10m</td> </tr> <tr> <td>230MHz...1GHz</td> <td>47dB(μV/m) Qpk at 10m</td> </tr> <tr> <td>1...3GHz</td> <td>Do not apply</td> </tr> <tr> <td></td> <td></td> <td></td> <td>3...6GHz</td> <td>Internal freq. < 108MHz</td> </tr> <tr> <td rowspan="2">Conducted emissions</td> <td rowspan="2">IEC55016</td> <td rowspan="2">Input</td> <td>150kHz...500kHz</td> <td>79dB(μV) Qpk, 66dB(μV) Av</td> </tr> <tr> <td>500kHz...30MHz</td> <td>73dB(μV) Qpk, 60dB(μV) Av</td> </tr> </tbody> </table>	Test	Norm	Port	Frequency	Limits	Radiated emissions	IEC55016	Case	30MHz...230MHz	40dB(μV/m) Qpk at 10m	230MHz...1GHz	47dB(μV/m) Qpk at 10m	1...3GHz	Do not apply				3...6GHz	Internal freq. < 108MHz	Conducted emissions	IEC55016	Input	150kHz...500kHz	79dB(μV) Qpk, 66dB(μV) Av	500kHz...30MHz	73dB(μV) Qpk, 60dB(μV) Av																																												
		Test	Norm	Port	Frequency	Limits																																																																		
		Radiated emissions	IEC55016	Case	30MHz...230MHz	40dB(μV/m) Qpk at 10m																																																																		
					230MHz...1GHz	47dB(μV/m) Qpk at 10m																																																																		
					1...3GHz	Do not apply																																																																		
					3...6GHz	Internal freq. < 108MHz																																																																		
		Conducted emissions	IEC55016	Input	150kHz...500kHz	79dB(μV) Qpk, 66dB(μV) Av																																																																		
					500kHz...30MHz	73dB(μV) Qpk, 60dB(μV) Av																																																																		
		<table border="1"> <thead> <tr> <th>Test</th> <th>Norm</th> <th>Port</th> <th>Severity</th> <th>Conditions</th> <th>P</th> </tr> </thead> <tbody> <tr> <td rowspan="2">Electrostatic discharge</td> <td rowspan="2">IEC61000-4-2</td> <td rowspan="2">Case</td> <td>±8kV</td> <td>Air (isolated parts)</td> <td rowspan="2">B</td> </tr> <tr> <td>±8kV</td> <td>Contact (conductive parts)</td> </tr> <tr> <td rowspan="4">Radiated high-frequency</td> <td rowspan="4">IEC61000-4-3</td> <td rowspan="4">X/Y/Z Axis</td> <td>20V/m</td> <td>0.08...1.0GHz M. 80% 1kHz</td> <td rowspan="4">A</td> </tr> <tr> <td>10V/m</td> <td>1.4...2.1GHz M. 80% 1kHz</td> </tr> <tr> <td>5V/m</td> <td>2.1...2.5GHz M. 80% 1kHz</td> </tr> <tr> <td>3V/m</td> <td>5.1...6GHz M. 80% 1kHz</td> </tr> <tr> <td rowspan="4">Fast transients</td> <td rowspan="4">IEC61000-4-4</td> <td>Input</td> <td>±2kV</td> <td rowspan="4">Tr/Th: 5/50 ns</td> <td rowspan="4">A</td> </tr> <tr> <td>Output</td> <td>±2kV</td> </tr> <tr> <td>Signal</td> <td>±2kV</td> </tr> <tr> <td>PE</td> <td>±1kV</td> </tr> <tr> <td rowspan="2">Surge</td> <td rowspan="2">IEC61000-4-5</td> <td>Input L to L</td> <td>±1kV</td> <td rowspan="2">Tr/Th: 1.2/50μs</td> <td rowspan="2">B</td> </tr> <tr> <td>Input L to PE</td> <td>±2kV</td> </tr> <tr> <td rowspan="4">Conducted RF</td> <td rowspan="4">IEC61000-4-6</td> <td>Input</td> <td>10V</td> <td rowspan="4">0.15...80MHz M. 80% 1kHz</td> <td rowspan="4">A</td> </tr> <tr> <td>Output</td> <td>10V</td> </tr> <tr> <td>Signal</td> <td>10V</td> </tr> <tr> <td>PE</td> <td>10V</td> </tr> <tr> <td>Magnetic field</td> <td>IEC61000-4-8</td> <td>X/Y/Z Axis</td> <td>300A/m</td> <td>0Hz, 16.7Hz, 50/60Hz</td> <td>A</td> </tr> <tr> <td>Pulse magnetic field</td> <td>IEC61000-4-9</td> <td>X/Y/Z Axis</td> <td>300A/m</td> <td>Tr/Th: 6.4/16μs</td> <td>B</td> </tr> </tbody> </table>	Test	Norm	Port	Severity	Conditions	P	Electrostatic discharge	IEC61000-4-2	Case	±8kV	Air (isolated parts)	B	±8kV	Contact (conductive parts)	Radiated high-frequency	IEC61000-4-3	X/Y/Z Axis	20V/m	0.08...1.0GHz M. 80% 1kHz	A	10V/m	1.4...2.1GHz M. 80% 1kHz	5V/m	2.1...2.5GHz M. 80% 1kHz	3V/m	5.1...6GHz M. 80% 1kHz	Fast transients	IEC61000-4-4	Input	±2kV	Tr/Th: 5/50 ns	A	Output	±2kV	Signal	±2kV	PE	±1kV	Surge	IEC61000-4-5	Input L to L	±1kV	Tr/Th: 1.2/50μs	B	Input L to PE	±2kV	Conducted RF	IEC61000-4-6	Input	10V	0.15...80MHz M. 80% 1kHz	A	Output	10V	Signal	10V	PE	10V	Magnetic field	IEC61000-4-8	X/Y/Z Axis	300A/m	0Hz, 16.7Hz, 50/60Hz	A	Pulse magnetic field	IEC61000-4-9	X/Y/Z Axis	300A/m	Tr/Th: 6.4/16μs	B
		Test	Norm	Port	Severity	Conditions	P																																																																	
		Electrostatic discharge	IEC61000-4-2	Case	±8kV	Air (isolated parts)	B																																																																	
					±8kV	Contact (conductive parts)																																																																		
		Radiated high-frequency	IEC61000-4-3	X/Y/Z Axis	20V/m	0.08...1.0GHz M. 80% 1kHz	A																																																																	
					10V/m	1.4...2.1GHz M. 80% 1kHz																																																																		
					5V/m	2.1...2.5GHz M. 80% 1kHz																																																																		
3V/m	5.1...6GHz M. 80% 1kHz																																																																							
Fast transients	IEC61000-4-4	Input	±2kV	Tr/Th: 5/50 ns	A																																																																			
		Output	±2kV																																																																					
		Signal	±2kV																																																																					
		PE	±1kV																																																																					
Surge	IEC61000-4-5	Input L to L	±1kV	Tr/Th: 1.2/50μs	B																																																																			
		Input L to PE	±2kV																																																																					
Conducted RF	IEC61000-4-6	Input	10V	0.15...80MHz M. 80% 1kHz	A																																																																			
		Output	10V																																																																					
		Signal	10V																																																																					
		PE	10V																																																																					
Magnetic field	IEC61000-4-8	X/Y/Z Axis	300A/m	0Hz, 16.7Hz, 50/60Hz	A																																																																			
Pulse magnetic field	IEC61000-4-9	X/Y/Z Axis	300A/m	Tr/Th: 6.4/16μs	B																																																																			
P = Performance criteria, L= Line, PE= Protective Earth																																																																								
4.3.7	Relative humidity	Up to 95%																																																																						
5.1.1.2	DC power supply range	From 0.70 to 1.25 Un continuous																																																																						
5.1.1.3	Temporary DC power supply fluctuation	From 0.60 to 1.40 Un 0.1s From 1.25 to 1.40 Un 1s without damage																																																																						
5.1.1.4	Interruptions of voltage supply	Class S1 (without interruptions)																																																																						
5.1.1.6	Input ripple factor	10% peak to peak with a DC Ripple Factor of 5 %																																																																						
5.1.3	Supply change-over	0,6 Un duration 100 ms (without interruptions). Performance criterion A																																																																						
7.2.7	Input reverse polarity protection	By fuse																																																																						
10.7	Protective coating for PCB assemblies	Class PC2																																																																						
13.3	Tests list	<table border="0"> <tbody> <tr><td>1 Visual Inspection</td><td>Routine</td></tr> <tr><td>2 Performance test</td><td>Routine</td></tr> <tr><td>3 Power supply test</td><td>Routine</td></tr> <tr><td>4 Insulation test</td><td>Routine</td></tr> <tr><td>5 Low temperature storage test</td><td>-</td></tr> <tr><td>6 Low temperature start-up test</td><td>Type</td></tr> <tr><td>7 Dry heat test</td><td>Type</td></tr> <tr><td>8 Cyclic damp heat test</td><td>Type</td></tr> <tr><td>9 Salt mist test</td><td>-</td></tr> <tr><td>10 Enclosure protection test (IP code)</td><td>-</td></tr> <tr><td>11 EMC test</td><td>Type</td></tr> <tr><td>12 Shocks and vibrations test</td><td>Type</td></tr> <tr><td>13 Equipment stress screening test</td><td>Routine: 24h at 40°C and load 100%</td></tr> <tr><td>14 Rapid Temperature variation test</td><td>Type</td></tr> </tbody> </table>	1 Visual Inspection	Routine	2 Performance test	Routine	3 Power supply test	Routine	4 Insulation test	Routine	5 Low temperature storage test	-	6 Low temperature start-up test	Type	7 Dry heat test	Type	8 Cyclic damp heat test	Type	9 Salt mist test	-	10 Enclosure protection test (IP code)	-	11 EMC test	Type	12 Shocks and vibrations test	Type	13 Equipment stress screening test	Routine: 24h at 40°C and load 100%	14 Rapid Temperature variation test	Type																																										
1 Visual Inspection	Routine																																																																							
2 Performance test	Routine																																																																							
3 Power supply test	Routine																																																																							
4 Insulation test	Routine																																																																							
5 Low temperature storage test	-																																																																							
6 Low temperature start-up test	Type																																																																							
7 Dry heat test	Type																																																																							
8 Cyclic damp heat test	Type																																																																							
9 Salt mist test	-																																																																							
10 Enclosure protection test (IP code)	-																																																																							
11 EMC test	Type																																																																							
12 Shocks and vibrations test	Type																																																																							
13 Equipment stress screening test	Routine: 24h at 40°C and load 100%																																																																							
14 Rapid Temperature variation test	Type																																																																							