

60W isolated DC-DC converter in DIP package  
Ultra-wide input and regulated single output



Patent Protection RoHS

## FEATURES

- Ultra-wide 4:1 input voltage range
- High efficiency up to 93.3%
- I/O isolation test voltage 1.5K VDC
- Input under-voltage protection, output short-circuit, over-current, over-voltage protection
- Operating ambient temperature range: -40°C to +105°C
- Six-sided metal shielding package
- Industry standard pin-out

URB24\_LD-60W(H)R3 series of isolated 60W DC-DC converter products with an ultra-wide 4:1 input voltage range. They feature efficiencies up to 93%, input to output isolation is tested with 1500VDC and the converter safety operate ambient temperature of -40°C to +105°C, input under-voltage protection, output over-voltage, over-current, short-circuit protection. They are ideally and widely used in applications such as industrial control, electric power, instruments and communications fields.

## Selection Guide

Certification	Part No.	Input Voltage (VDC)		Output		Full Load Efficiency <sup>②</sup> (%) Min./Typ.	Capacitive Load (μF)Max.
		Nominal (Range)	Max. <sup>①</sup>	Voltage (VDC)	Current(mA) Max./Min.		
--	URB2405LD-60W(H)R3	24(9-36)	40	05	12000/600	90/92	20000
	URB2412LD-60W(H)R3			12	5000/250	91/93	6000
	URB2415LD-60W(H)R3			15	4000/200	91/93.3	4000
	URB2424LD-60W(H)R3			24	2500/125	91/93	2000

Notes:

- ①Exceeding the maximum input voltage may cause permanent damage;  
②Efficiency is measured at nominal input voltage and rated output load.

## Input Specifications

Item	Operating Conditions	Min.	Typ.	Max.	Unit
Input Current (full load / no-load)	Nominal input voltage	--	2718/25	2748/30	mA
Surge Voltage (1sec. max.)		-0.7	--	50	VDC
Start-up Voltage		--	--	9	
Input Filter		PI filter			
Hot Plug		Unavailable			
Ctrl*	Module on	Ctrl pin open or pulled high TTL (3-12VDC)			
	Module off	Ctrl pin pulled low to GND (0-1.2VDC)			

Note: \*The Ctrl pin voltage is referenced to input GND.

## Output Specifications

Item	Operating Conditions	Min.	Typ.	Max.	Unit
Voltage Accuracy	5%-100% load	--	±1	±2	%
	0%-5% load	--	±2	±5	
Linear Regulation	Input voltage variation from low to high at full load	--	±0.2	±0.5	
Load Regulation	5%-100% load	--	±0.5	±1	
Transient Response Deviation	25% load step change, input voltage range	5V output	--	±3	
		Other output	--	±3	±5
Transient Recovery Time	25% load step change, nominal input voltage	--	250	500	μs

Temperature Coefficient	Full load	--	--	±0.03	%/°C	
Ripple & Noise <sup>①</sup>	20MHz bandwidth, nominal input voltage, 5%-100% load	5V/12V/ 15V output	--	100	--	mV p-p
		24V output	--	130	--	
	20MHz bandwidth, nominal input, voltage, 0%-5% load	--	--	3		%Vo
Over-voltage Protection	Input voltage range	110	140	160		
Over-current Protection		110	140	200		%Io
Short-circuit Protection		Continuous, self-recovery				
Note: ①By measuring method is used for Ripple and Noise test, please refer to Fig. 2. for recommended circuit.						

## General Specifications

Item	Operating Conditions	Min.	Typ.	Max.	Unit
Isolation	Input-output Electric Strength Test for 1 minute with a leakage current of 1mA max.	1500	--	--	VDC
	Input/output-Case Electric Strength Test for 1 minute with a leakage current of 1mA max.	1000	--	--	
Insulation Resistance	Input-output resistance at 500VDC	100	--	--	MΩ
Isolation Capacitance	Input-output capacitance at 100KHz/0.1V	--	2200	--	pF
Operating Temperature	See Fig. 1	-40	--	+105	°C
Storage Temperature		-55	--	+125	
Storage Humidity	Non-condensing	5	--	95	%RH
Pin Soldering Resistance Temperature	Soldering spot is 1.5mm away from case for 10 seconds	--	--	+300	°C
Vibration		10-150Hz, 5G, 0.75mm. along X, Y and Z			
Switching Frequency <sup>①</sup>	PWM mode	--	370	--	KHz
MTBF	MIL-HDBK-217F@25°C	1000	--	--	K hours
Note: ①Switching frequency is measured at full load. The module reduces the switching frequency for light load (below 50%) efficiency improvement.					

## Mechanical Specifications

Case Material	Aluminum alloy				
Dimensions	Without heat sink	Horizontal package	50.80 x 25.40 x 11.80 mm		
	Heat sink		51.40 x 26.20 x 16.50 mm		
Weight	Without heat sink		41.0g		
	Heat sink		50.8g		
Cooling Method	Free air convection				

## Electromagnetic Compatibility (EMC)

Emissions	CE	CISPR32/EN55032 CLASS A (Vout=12/15V see Fig. 3-① for recommended circuit, Vout=05/24V see Fig. 3-③ for recommended circuit) / CLASS B (Vout=12/15V see Fig. 3-② for recommended circuit, Vout=05/24V see Fig. 3-④ for recommended circuit)			
	RE	CISPR32/EN55032 CLASS A (Vout=12/15V see Fig. 3-① for recommended circuit, Vout=05/24V see Fig. 3-③ for recommended circuit) / CLASS B (Vout=12/15V see Fig. 3-② for recommended circuit, Vout=05/24V see Fig. 3-④ for recommended circuit)			
Immunity	ESD	IEC/EN61000-4-2	Contact ±6KV/Air ±8KV		perf. Criteria B
	RS	IEC/EN61000-4-3	10V/m		perf. Criteria A
	EFT	IEC/EN61000-4-4	100KHz ±2KV (Vout=12/15V see Fig. 3-② for recommended circuit, Vout=05/24V see Fig. 3-④ for recommended circuit)		perf. Criteria A
	Surge	IEC/EN61000-4-5	line to line ±2KV (Vout=12/15V see Fig. 3-② for recommended circuit, Vout=05/24V see Fig. 3-④ for recommended circuit)		perf. Criteria A
	CS	IEC/EN61000-4-6	10 Vr.m.s		perf. Criteria A

Typical Characteristic Curves

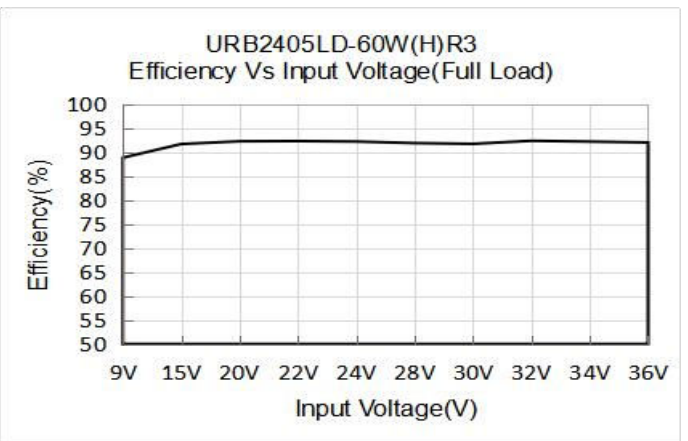
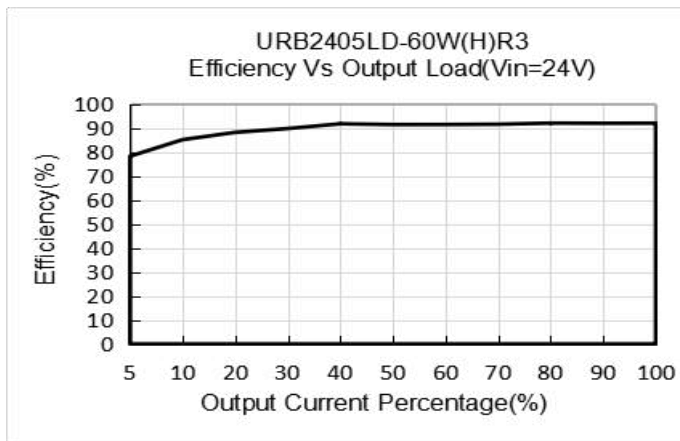
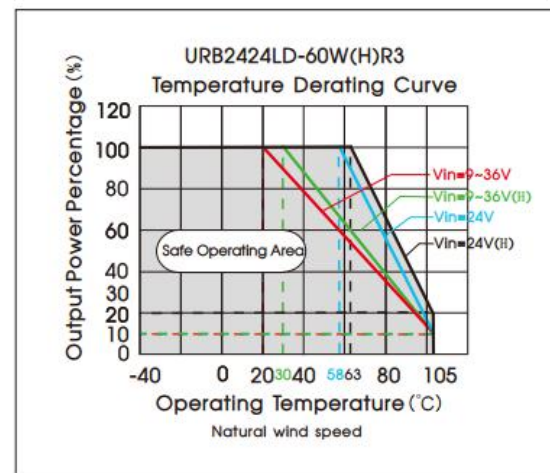
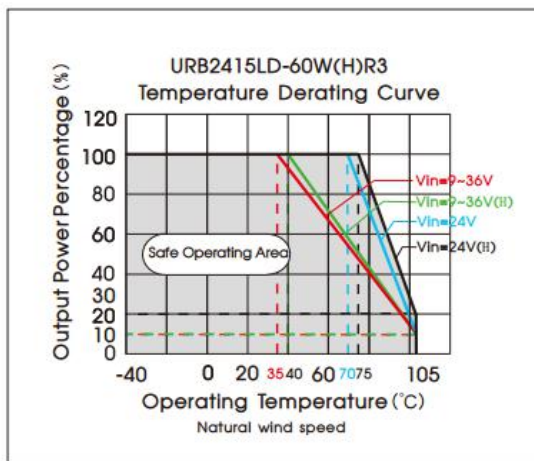
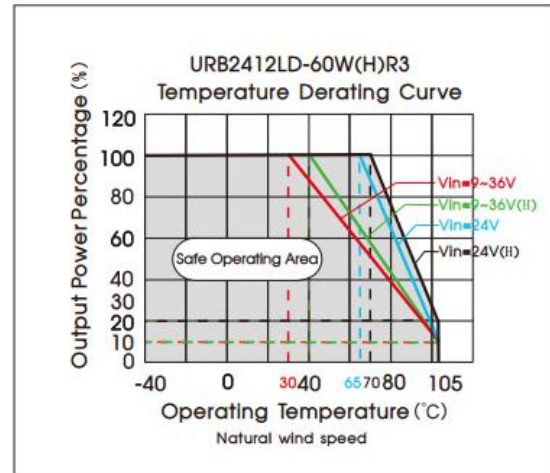
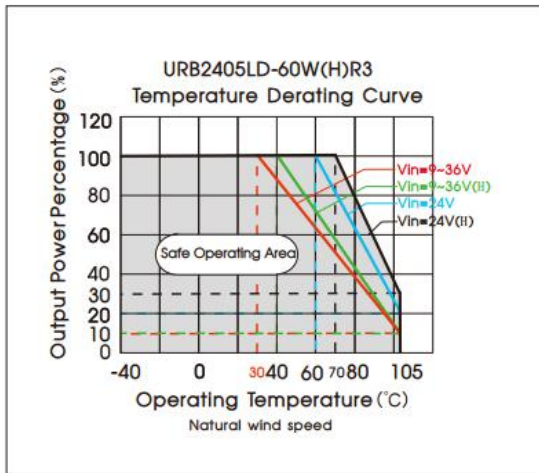

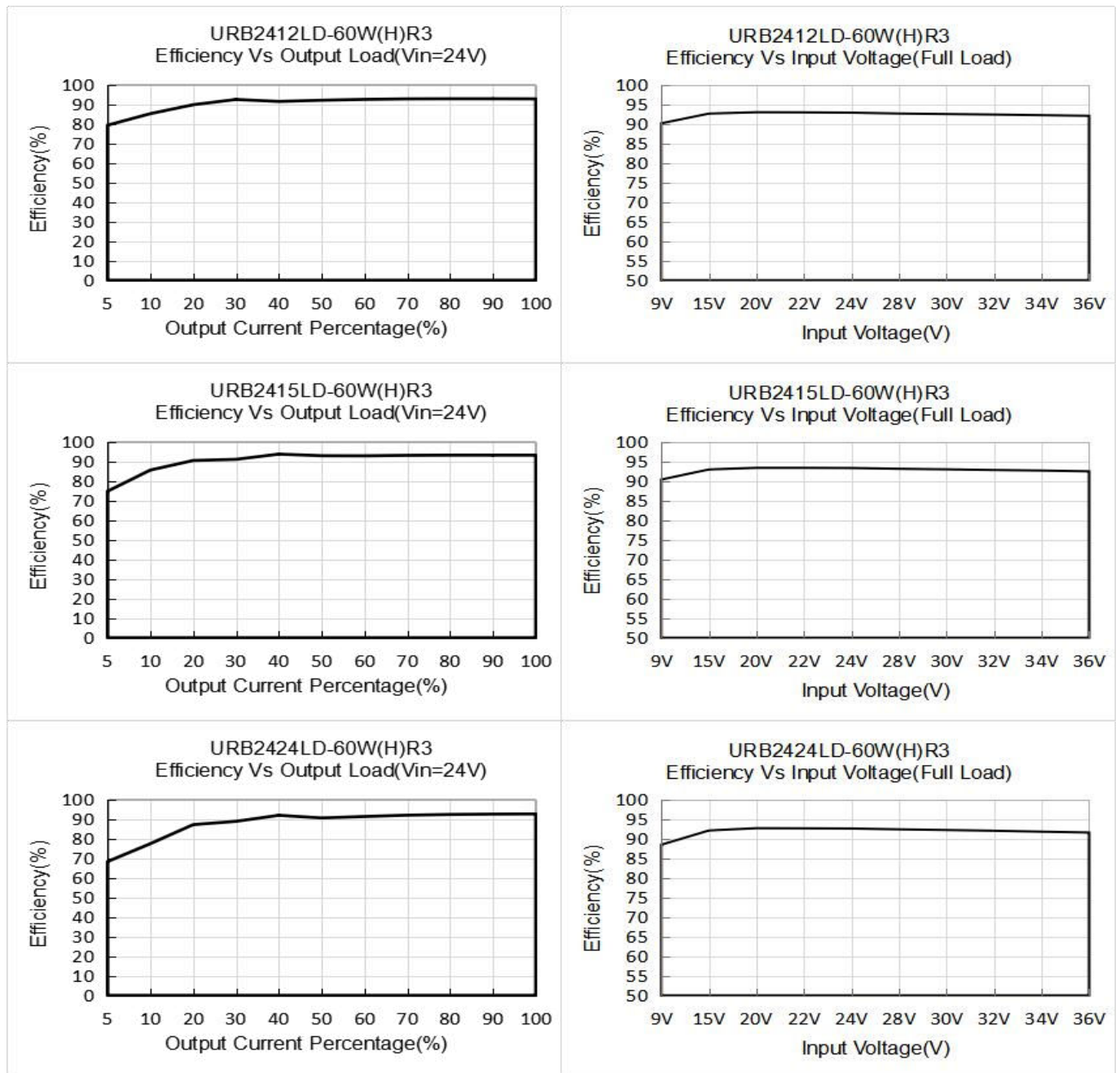

Fig. 1

## Design Reference

### 1. Typical application

All the DC-DC converters of this series are tested before delivery using the recommended circuit shown in Fig. 2.

Input and/or output ripple can be further reduced by appropriately increasing the input & output capacitor values  $C_{in}$  and  $C_{out}$  and/or by selecting capacitors with a low ESR (equivalent series resistance). Also make sure that the capacitance is not exceeding the specified max. capacitive load value of the product.



Fig. 2

Vout (VDC)	Cin ( $\mu$ F)	Cout ( $\mu$ F)
5	100 $\mu$ F/50V	220 $\mu$ F/16V
12/15		100 $\mu$ F/50V
24		47 $\mu$ F/50V

2. EMC compliance circuit

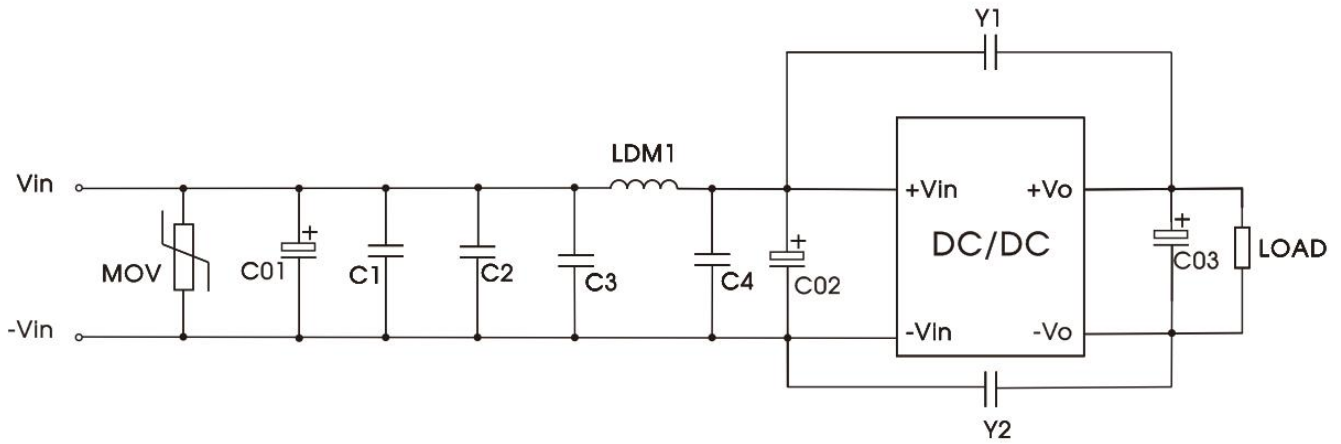

Fig. 3-①

Table 1: recommended component parameters

Model	Parameter	Parameter description
C1/C2	4.7uF	50V
C3/C4	10uF	50V
C01	680uF	50V
C02	330uF	50V
C03	100uF	100V
Y1/Y2	2.2nF	Y1
LDM1	2.2uH	/
MOV	14D470	/

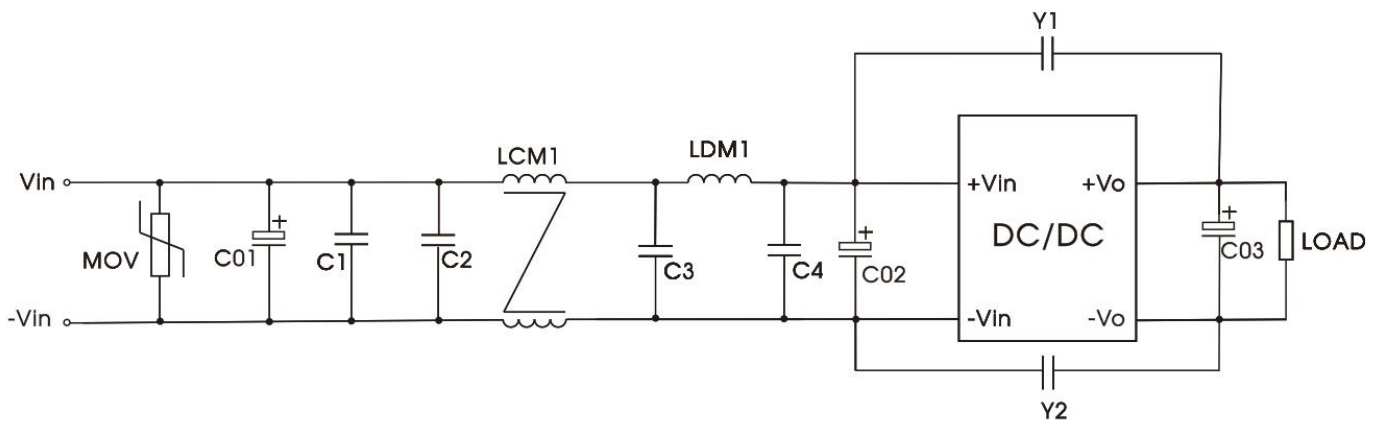

Fig. 3-②

Table 2: recommended component parameters

Model	Parameter	Parameter description
C1/C2	4.7uF	50V
C3/C4	10uF	50V
C01	680uF	50V
C02	330uF	50V
C03	100uF	100V
Y1/Y2	2.2nF	Y1
LCM1	2.2mH	recommended to use MORNSUN P/N: FL2D-30-222

LDM1	2.2uH	/
MOV	14D470	/

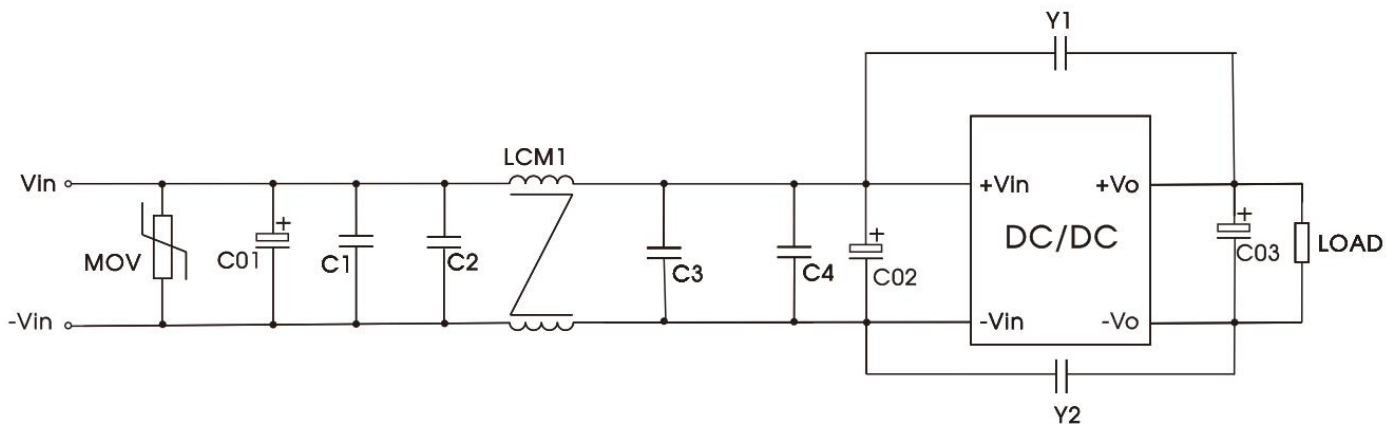

Fig. 3-3

Table 3: recommended component parameters

Model	Parameter	Parameter description
C1/C2	4.7uF	50V
C3/C4	10uF	50V
C01	680uF	50V
C02	330uF	50V
C03	100uF	100V
Y1/Y2	2.2nF	Y1
LCM1	10mH	10.0mH MIN/180mΩ Max
MOV	14D470	/

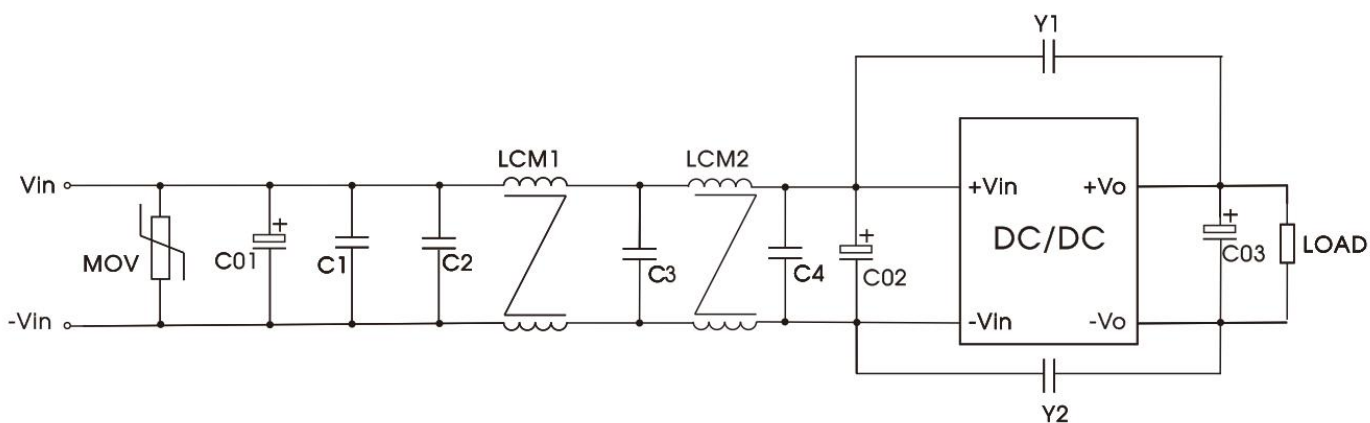
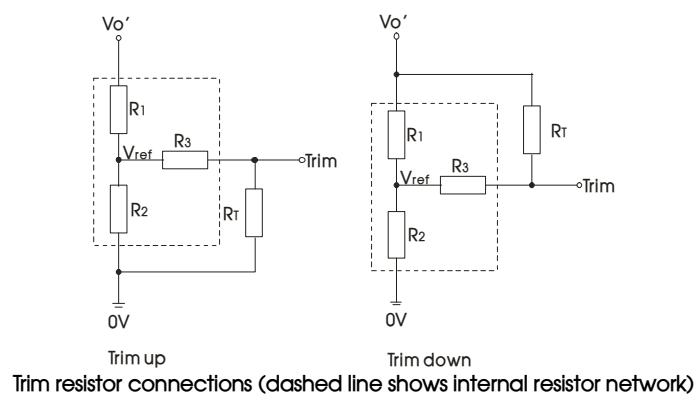

Fig. 3-4

Table 4: recommended component parameters

Model	Parameter		Parameter description
C1/C2	4.7uF		50V
C3	10uF		50V
C4	URB2405LD-60WR3	10uF	50V
	URB2424LD-60WR3	47uF	
C01	680uF		50V
C02	330uF		50V
C03	100uF		100V
Y1/Y2	2.2nF		Y1
LCM1/LCM2	10mH		10.0mH MIN/180mΩ Max
MOV	14D470		/

### 3. Trim Function for Output Voltage Adjustment (open if unused)



Calculating Trim resistor values:

$$\begin{aligned} \text{up: } R_T &= \frac{\alpha R_2}{R_2 - \alpha} \cdot R_3 & \alpha &= \frac{V_{ref}}{V_{o'} - V_{ref}} \cdot R_1 \\ \text{down: } R_T &= \frac{\alpha R_1}{R_1 - \alpha} \cdot R_3 & \alpha &= \frac{V_{o'} - V_{ref}}{V_{ref}} \cdot R_2 \end{aligned}$$

$R_T$  = Trim Resistor value  
 $\alpha$  = self-defined parameter  
 $V_{o'}$  = desired output voltage

Vout(VDC)	R1(KΩ)	R2(KΩ)	R3(KΩ)	Vref(V)
05	2.97	2.87	6.1	2.5
12	10.91	2.87	6.1	2.5
15	14.35	2.87	6.1	2.5
24	24.77	2.87	6.1	2.5

### 4. Recommended solution for thermal testing

During the application process, the thermal design of the product can be evaluated in combination with the temperature derating curve of the product, or it can be determined by testing the temperature at point A, it is an safe operating area if the temperature lower than 100°C.



5. Reflected ripple current test circuit

All DC-DC converters of this series are tested using the recommended circuit shown in Fig. 5. Test point,

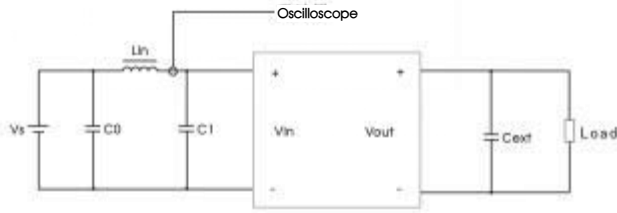

Fig. 5

Components	Recommended Component value
C0	220μF/100V
Lin	10uH/15A
C1	470μF/100V
Cext	470μF/63V

6. The products do not support parallel connection of their output

7. For additional information please refer to DC-DC converter application notes on [www.mornsun-power.com](http://www.mornsun-power.com)

URB24\_LD-60WR3 Dimensions and Recommended Layout

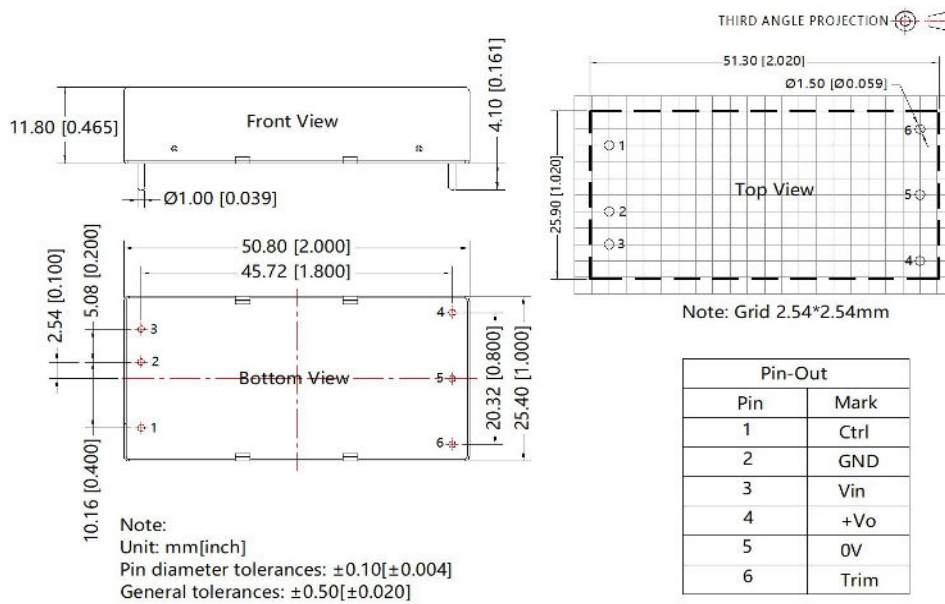



URB24\_LD-60WHR3 Dimensions and Recommended Layout

THIRD ANGLE PROJECTION 

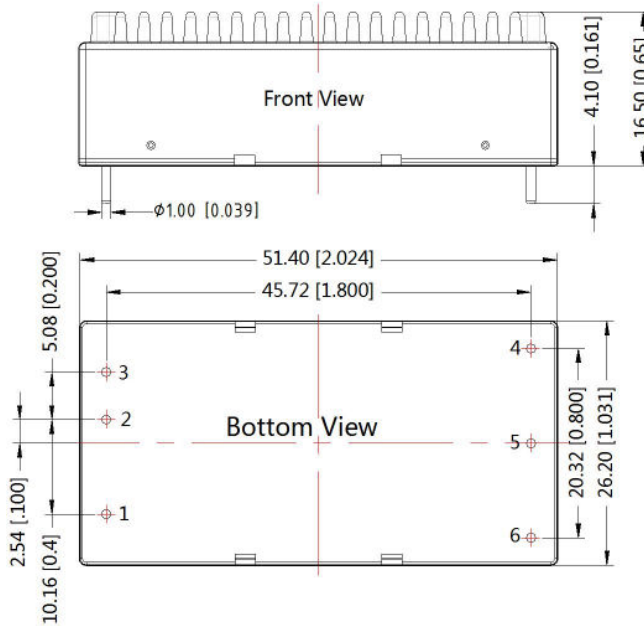

Pin-Out	
Pin	Function
1	Ctrl
2	GND
3	Vin
4	+Vo
5	0V
6	Trim

Note:  
Unit: mm[inch]  
General tolerances:  $\pm 0.50[\pm 0.020]$

- Note:
- For additional information on Product Packaging please refer to [www.mornsun-power.com](http://www.mornsun-power.com). Packaging number: 58200035(without heat sink), 58200051(with heat sink);
  - Recommended used in more than 10% load, if the load is lower than 10%, then the ripple index of the product may exceed the specification, but does not affect the reliability of the product;
  - If the product is not operated within the required load range, the product performance cannot be guaranteed to comply with all parameters in the datasheet;
  - The maximum capacitive load offered were tested at input voltage range and full load;
  - Unless otherwise specified, parameters in this datasheet were measured under the conditions of  $T_a=25^\circ\text{C}$ , humidity<75%RH with nominal input voltage and rated output load;
  - All index testing methods in this datasheet are based on company corporate standards;
  - We can provide product customization service, please contact our technicians directly for specific information;
  - Products are related to laws and regulations: see "Features" and "EMC";
  - Our products shall be classified according to ISO14001 and related environmental laws and regulations, and shall be handled by qualified units.

Mornsun Guangzhou Science & Technology Co., Ltd.

Address: No. 5, Kehui St. 1, Kehui Development Center, Science Ave., Guangzhou Science City, Huangpu District, Guangzhou, P. R. China  
Tel: 86-20-38601850 Fax: 86-20-38601272 E-mail: [info@mornsun.cn](mailto:info@mornsun.cn) [www.mornsun-power.com](http://www.mornsun-power.com)