

5W, DIY AC/DC converter



EN62368-1

## FEATURES

- Ultra-wide 85 - 305VAC and 70 - 430VDC input voltage range
- Accepts AC or DC input (dual-use of same terminal)
- Operating ambient temperature range: -40°C to +85°C
- High I/O isolation test voltage up to 4000VAC
- Multi application, compact size, flexible layout
- No-load power consumption 0.1W
- Output short circuit, over-current protection
- Plastic case meets UL94V-0 flammability
- Pollution degree 3 (meet IEC62368-1)

LS05-23BxxDR3 series is one of Mornsun's miniaturized potting highly efficient green power AC-DC Converters. They feature wide input range accepting either AC or DC voltage, high reliability, low power consumption, reinforced isolation and strong applicability. All models are particularly suitable for industrial control, electric power, instrumentation and smart home applications which have high requirement for dimension and don't have high requirement on EMC. For extremely harsh EMC environment, we recommend using the application circuit show in Design Reference of this datasheet.

## Selection Guide

Certification	Part No.	Output Power	Nominal Output Voltage and Current (Vo/Io)	Efficiency at 230VAC (%) Typ.	Capacitive Load (uF) Max.
EN	LS05-23B03DR3	5W	3.3V/1000mA	68	2200
	LS05-23B05DR3		5V/1000mA	71	1500
	LS05-23B09DR3		9V/560mA	74	680
	LS05-23B12DR3		12V/420mA	75	470
	LS05-23B15DR3		15V/340mA	77	330
	LS05-23B24DR3		24V/210mA	77	100

Note: The nominal output voltage refers to the voltage applied to the load terminal after adding external circuits.

## Input Specifications

Item	Operating Conditions	Min.	Typ.	Max.	Unit
Input Voltage Range	AC input	85	--	305	VAC
	DC input	70	--	430	VDC
Input Frequency		47	--	63	Hz
Input Current	115VAC	--	--	0.2	A
	230VAC	--	--	0.1	
Inrush Current	115VAC	--	20	--	
	230VAC	--	40	--	
Recommended External Input Fuse		1A, slow-blow, required (The actual use needs to be selected according to the application environment)			
Hot Plug		Unavailable			

## Output Specifications

Item	Operating Conditions	Min.	Typ.	Max.	Unit
Output Voltage Accuracy	10% - 100% load	--	±5	--	%
Line Regulation	Rated load	--	±1.5	--	
Load Regulation	10% - 100% load	--	±3	--	
Ripple & Noise*	20MHz bandwidth (peak-to-peak value), 10% - 100% load	--	80	150	mV
Temperature Coefficient		--	±0.15	--	%/°C
Stand-by Power Consumption	230VAC	--	0.10	0.15	W

Short Circuit Protection		Hiccup, continuous, self-recovery			
Over-current Protection		≥110%Io, self-recovery			
Minimum Load		10	--	--	%
Hold-up Time	115VAC input	--	8	--	ms
	230VAC input	--	40	--	
Note: 1. * The "parallel cable" method is used for ripple and noise test, please refer to AC-DC Converter Application Notes for specific information; 2. The product is able to work with 0%-10% load and with stable output.					

## General Specifications

Item		Operating Conditions	Min.	Typ.	Max.	Unit
Isolation	Input-output	Electric Strength Test for 1min., leakage current <5mA	4000	--	--	VAC
Insulation Resistance	Input-output	At 500VDC	100	--	--	MΩ
Operating Temperature			-40	--	+85	°C
Storage Temperature			-40	--	+105	
Storage Humidity			--	--	95	%RH
Power Derating		+55°C to +85°C	1.67	--	--	% / °C
		85VAC - 100VAC	1.33	--	--	
		277VAC - 305VAC	0.72	--	--	
Safety Standard			Design refer to IEC/UL62368-1, IEC/EN60335-1, IEC/EN61558-1 & EN62368-1 (Report)			
Safety Class			CLASS II			
MTBF			MIL-HDBK-217F@25°C > 1,000,000 h			

## Mechanical Specifications

Case Material	Black plastic, flame-retardant and heat-resistant (UL94V-0)
Dimension	27.60 x 18.50 x 7.80 mm
Weight	7.5g (Typ.)
Cooling method	Free air convection

## Electromagnetic Compatibility (EMC)

Emissions	CE	CISPR32/EN55032	CLASS A (Application circuit 1, 4)	
		CISPR32/EN55032	CLASS B (Application circuit 2, 3, 5)	
RE		CISPR32/EN55032	CLASS A (Application circuit 1, 4)	
		CISPR32/EN55032	CLASS B (Application circuit 2, 3, 5)	
Immunity	ESD	IEC/EN61000-4-2	Contact ±6KV / Air ±8KV	Perf. Criteria B
	RS	IEC/EN61000-4-3	10V/m	perf. Criteria A
	EFT	IEC/EN61000-4-4	±2KV (Application circuit 1, 2)	perf. Criteria B
			±4KV (Application circuit 3, 4, 5)	perf. Criteria B
	Surge	IEC/EN61000-4-5	line to line ±1KV (Application circuit 1, 2)	perf. Criteria B
			line to line ±2KV (Application circuit 3, 4)	perf. Criteria B
		IEC/EN61000-4-5	line to line ±2KV/line to ground ±4KV (Application circuit 5)	perf. Criteria B
	CS	IEC/EN61000-4-6	10Vr.m.s	perf. Criteria A
Voltage dip, short interruption and voltage variation	IEC/EN61000-4-11	0%, 70%	perf. Criteria A	

Product Characteristic Curve

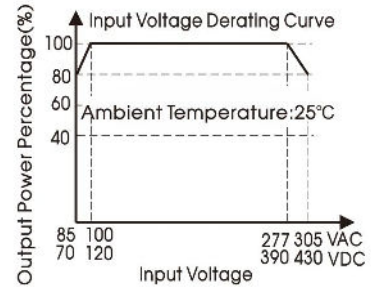
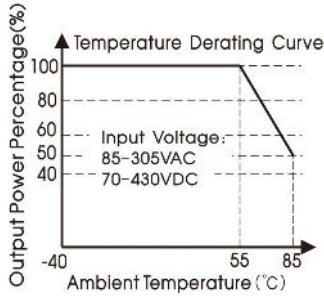

Note: ① With an AC input between 85-100VAC/277-305VAC and a DC input between 70-120VDC/390-430VDC, the output power must be derated as per temperature derating curves;

② This product is suitable for applications using natural air cooling; for applications in closed environment please consult factory or one of our FAE.

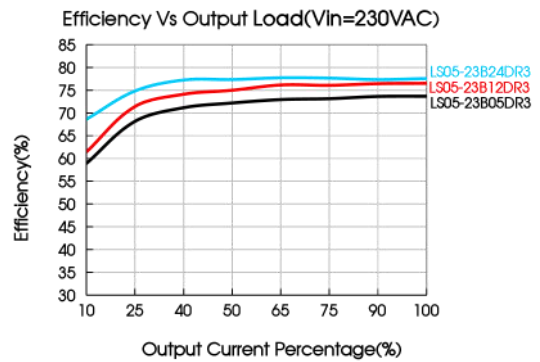
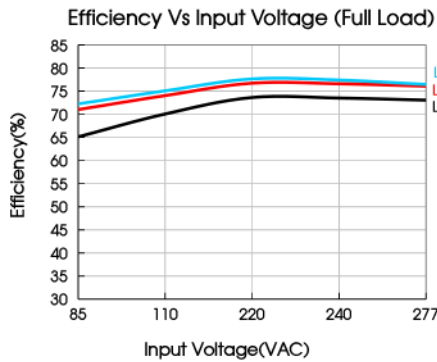

Additional Circuits Design Reference

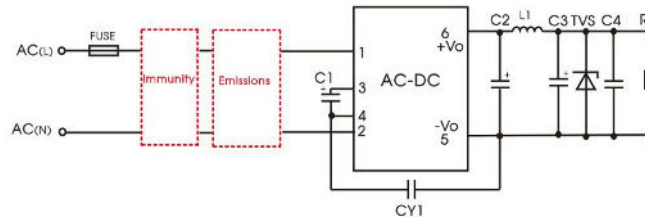

LS series additional circuits design reference

LS05 series additional components selection guide (No EMC devices)

Part No.	C1(required)	C2 (required)	L1 (required)	C3 (required)	C4	CY1 (required)	TVS
LS05-23B03DR3	10uF/450V (-25°C to +85°C, 85-305VAC input; -40°C to +85°C, 165-305VAC input) 22uF/450V (-40°C to +85°C, 85-305VAC input)	820uF/6.3V (solid-state capacitor)	2.2uH/36mΩ /3.3A	220uF/16V	0.1uF/ 50V	1.0nF/ 400VAC	SMBJ7.0A
LS05-23B05DR3		470uF/16V (solid-state capacitor)					SMBJ12A
LS05-23B09DR3		270uF/16V (solid-state capacitor)	4.7uH/60mΩ /2.2A	47uF/35V			SMBJ20A
LS05-23B12DR3		220uF/25V (solid-state capacitor)					SMBJ30A
LS05-23B15DR3		220uF/35V					
LS05-23B24DR3							

- Note:
- C1 is used as filter capacitor with AC input (must be connected externally) and as EMC filter capacitor with DC input (must be connected), and it is recommended to use the capacitor with ripple current >200mA@100KHz.
  - We recommend using an electrolytic capacitor with high frequency and low ESR (ESR of C3 at low temperature of -40°C ≤ 1.1Ω) rating for C3 (refer to manufacture's datasheet), electrolytic capacitor can be used for C2 when applied in normal and high temperature environments. Combined with C2, L1, they form a pi-type filter circuit. Choose a capacitor voltage rating with at least 20% margin, in other words not exceeding 80%. C4 is a ceramic capacitor, used for filtering high frequency noise.
  - A suppressor diode (TVS) is recommended to protect the application in case of converter failure and specification should be 1.2 times of the output voltage.

Environmental Application EMC Solution

Recommended circuit	Application environmental	Typical industry	Input voltage range	Environment temperature	Emissions	Immunity
1	Basic application	None	85-305VAC	-40°C to +85°C	CLASS A	CLASS III
2	Indoor civil environment	Smart home/Home appliances (2Y)		-25°C to +55°C	CLASS B	CLASS III
	Indoor general environment	Intelligent building/Intelligent agriculture		-25°C to +55°C	CLASS B	CLASS IV
3	Indoor industrial environment	Manufacturing workshop		-40°C to +85°C	CLASS A	CLASS IV
4	Outdoor general environment	ITS/Video monitoring/Charging point/Communication/Security and protection		-40°C to +85°C	Class B	CLASS IV

Electromagnetic Compatibility Solution—Recommended Circuit

1. Application circuit 1—Basic application

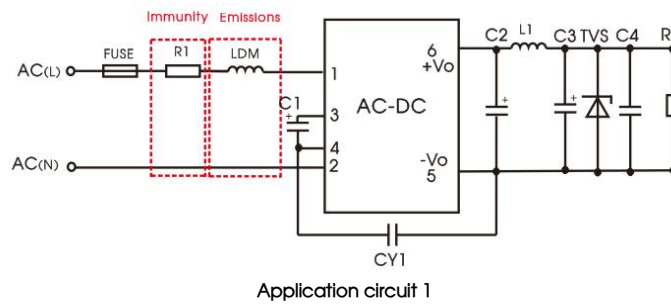

Application environmental	Ambient temperature range	Immunity CLASS	Emissions CLASS
Basic application	-40°C to +85°C	CLASS III	CLASS A

FUSE	1A/300V, slow-blow, required
R1	24 Ω /3W (wire-wound resistor, required)
LDM	4.7mH/Max: 15 Ω /Min: 0.2A

Note: R1 is the input plug-in resistor, this resistor needs to be a wire-wound resistor (required), please do not select chip resistor or carbon film resistor.

2. Application circuit 2—Universal system recommended circuits for indoor civil /general environment

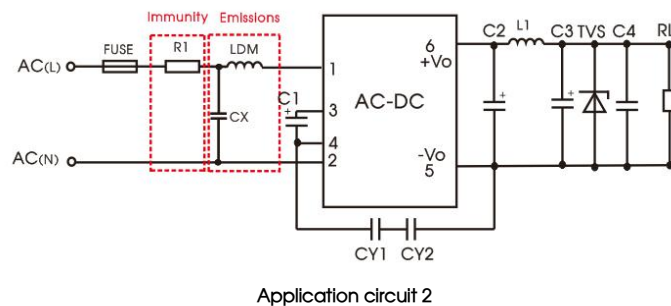

Application environmental	Ambient temperature range	Immunity CLASS	Emissions CLASS
Indoor civil /general	-25°C to +55°C	CLASS III	CLASS B

Component	Recommended value
R1	24 Ω /3W (wire-wound resistor, required)
LDM	4.7mH/Max: 15 Ω /Min: 0.2A
CX	0.1uF/310VAC
FUSE	1A/300V, slow-blow, required

Note 1: In the home appliance application environment, the two Y capacitors of the primary and secondary need to be externally connected (CY1/CY2, value at 2.2nF/250VAC), which can meet the EN60335 certification.  
 Note 2: According to the certification requirements, the X capacitor needs to be connected in parallel with the bleeder resistance, the recommended resistance value is less than 3.8MΩ, and the actual need to be selected according to the certification standard.  
 Note 3: R1 is the input plug-in resistor, this resistor needs to be a wire-wound resistor (required), please do not select chip resistor or carbon film resistor.

3. Application circuit 3—Universal system recommended circuits for indoor industrial environment

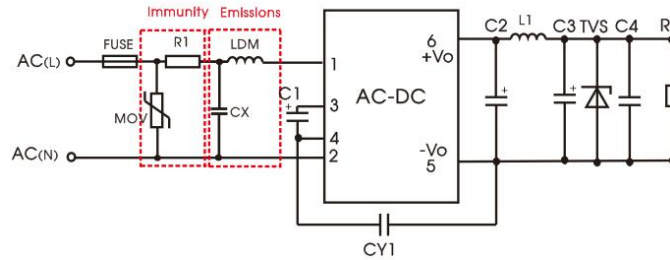

Application circuit 3

Application environmental	Ambient temperature range	Immunity CLASS	Emissions CLASS
Indoor industrial	-25℃ to +55℃	CLASS IV	CLASS B

Component	Recommended value
MOV	S14K350
CX	0.1uF/310VAC
LDM	4.7mH/Max: 15 Ω /Min: 0.2A
R1	33 Ω /3W (wire-wound resistor, required)
FUSE	2A/300V, slow-blow, required

Note 1: According to the certification requirements, the X capacitor needs to be connected in parallel with the bleeder resistance, the recommended resistance value is less than 3.8MΩ, and the actual need to be selected according to the certification standard.  
 Note 2: R1 is the input plug-in resistor, this resistor needs to be a wire-wound resistor (required), please do not select chip resistor or carbon film resistor.

4. Application circuit 4—Universal system recommended circuits for outdoor general environment

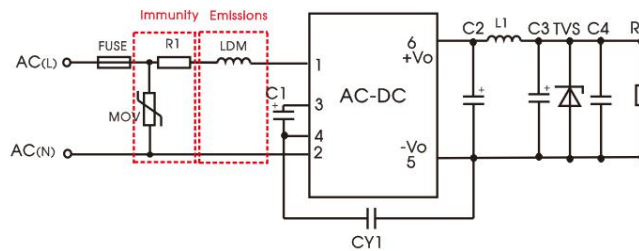

Application circuit 4

Application environmental	Ambient temperature range	Immunity CLASS	Emissions CLASS
Outdoor general environment	-40℃ to +85℃	CLASS IV	CLASS A

Component	Recommended value
MOV	S14K350
LDM	4.7mH/Max: 15 Ω /Min: 0.2A
R1	33 Ω /3W (wire-wound resistor, required)
FUSE	2A/300V, slow-blow, required

Note: R1 is the input plug-in resistor, this resistor needs to be a wire-wound resistor (required), please do not select chip resistor or carbon film resistor.

5. Application circuit 5—Universal system recommended circuits for outdoor industrial environment

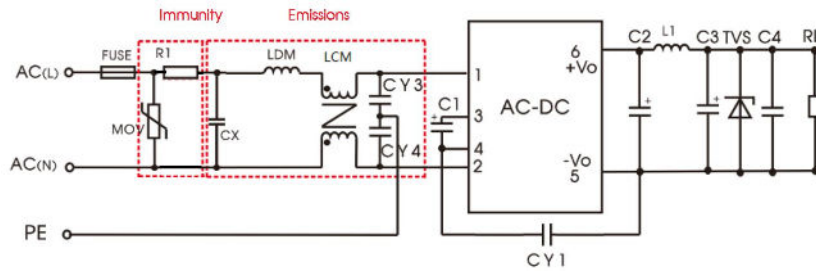

Application circuit 5

Application environmental	Ambient temperature range	Immunity CLASS	Emissions CLASS
Outdoor industrial environment	-40°C to +85°C	CLASS IV	CLASS B

Component	Recommended value
C1	22uF/450V
MOV	S14K350
CX	0.1uF/310VAC
LDM	330uH/960mΩ Max/0.31A
LCM	3.1mH
R1	47Ω /5W (wire-wound resistor, required)
CY3/CY4	1nF/400VAC
FUSE	2A/300V, slow-blow, required

Note 1: According to the certification requirements, the X capacitor needs to be connected in parallel with the bleeder resistance, the recommended resistance value is less than 3.8MΩ, and the actual need to be selected according to the certification standard.  
Note 2: R1 is the input plug-in resistor, this resistor needs to be a wire-wound resistor (required), please do not select chip resistor or carbon film resistor.

6. For additional information please refer to application notes on [www.mornsun-power.com](http://www.mornsun-power.com).

Dimensions and Recommended Layout

LS05-23BxxDR3 series dimensions

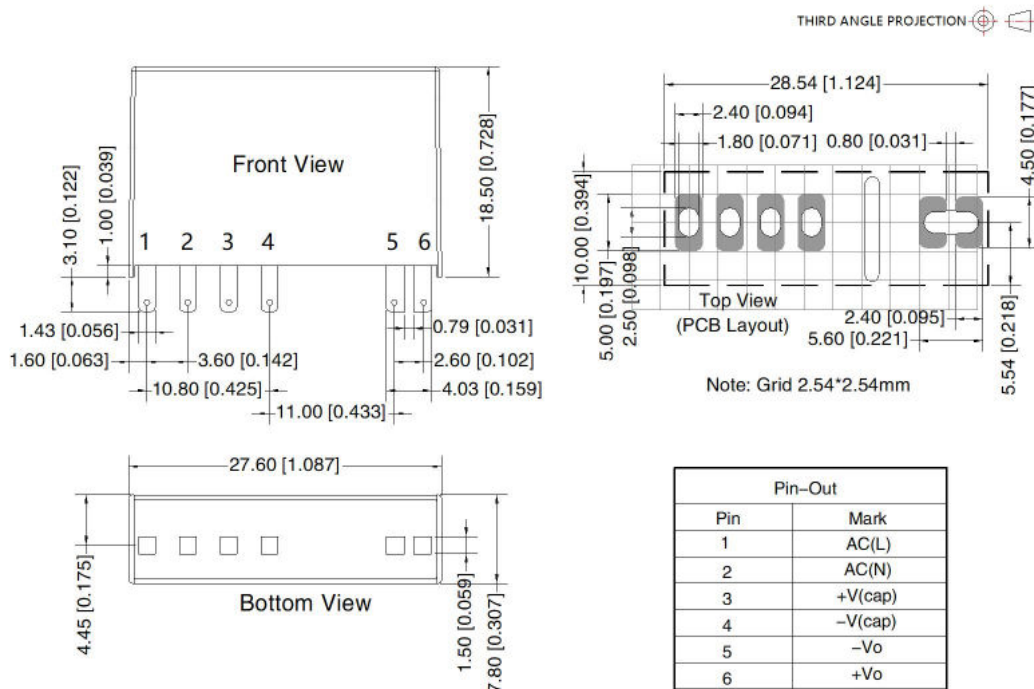

Note:  
Unit: mm[inch]  
Pin section tolerances: ±0.15[±0.006]  
General tolerances: ±0.50[±0.020]

LS05-23BxxDR3 series recommended pad

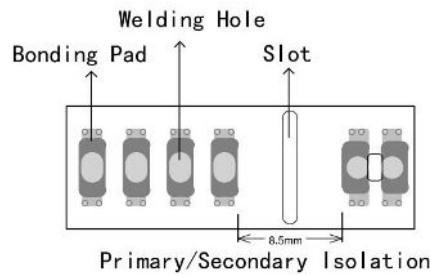

Note: There is a slot(non-metallic hole) between pin 4/5. For details, please refer to the recommended dimensions or pad.

Note:

1. For additional information on Product Packaging please refer to [www.mornsun-power.com](http://www.mornsun-power.com). Packaging bag number: 58220074;
2. External electrolytic capacitors are required to modules, more details refer to typical applications;
3. This series is a potting product, at least 6.4mm creepage distance between the primary and secondary external components of the module is needed to meet the safety requirement, refer to the recommended welding hole design in the external dimension drawing;
4. Unless otherwise specified, parameters in this datasheet were measured under the conditions of  $T_a=25^{\circ}\text{C}$ , humidity<75%, nominal input voltage (115V and 230V) and rated output load;
5. All index testing methods in this datasheet are based on our company corporate standards;
6. We can provide product customization service, please contact our technicians directly for specific information;
7. Products are related to laws and regulations: see "Features" and "EMC";
8. Our products shall be classified according to ISO14001 and related environmental laws and regulations, and shall be handled by qualified units.

Mornsun Guangzhou Science & Technology Co., Ltd.

Address: No. 5, Kehui St. 1, Kehui Development Center, Science Ave., Guangzhou Science City, Huangpu District, Guangzhou, P. R. China  
Tel: 86-20-38601850 Fax: 86-20-38601272 E-mail: [info@mornsun.cn](mailto:info@mornsun.cn) [www.mornsun-power.com](http://www.mornsun-power.com)