



## CFB600-300S SERIES 600 WATT 2:1 INPUT DC-DC CONVERTERS



### FEATURES

- \* 600W Isolated Output
- \* Efficiency to 91%
- \* Fixed Switching Frequency
- \* Input Under-Voltage Protection
- \* Over Temperature Protection
- \* Over Voltage/Current Protection
- \* Remote On/Off
- \* Single Wire Parallel
- \* Industry Full-Brick Package
- \* UL 60950-1 Approval
- \* Fully Isolated 3000VAC
- \* Safety Meets IEC/EN/UL 62368-1



MODEL NUMBER	INPUT VOLTAGE	OUTPUT VOLTAGE	OUTPUT CURRENT		INPUT CURRENT		% Eff.	CAPACITIVE LOAD MAX.
			MIN.	MAX.	NO LOAD	FULL LOAD		
CFB600-300S12	180-425 VDC	12 VDC	0 mA	50 A	10 mA	2.24 A	89.5	10000uF
CFB600-300S24	180-425 VDC	24 VDC	0 mA	25 A	10 mA	2.21 A	90.5	10000uF
CFB600-300S48	180-425 VDC	48 VDC	0 mA	12.5 A	10 mA	2.20 A	91	8000uF

#### NOTE:

1. Nominal Input Voltage 300 VDC.
2. The output terminal required a minimum capacitor 470uF to maintain specified regulation.
3. Measure at Nominal Input Voltage.

# SPECIFICATIONS

All Specifications Typical at Nominal Line, Full Load, and 25°C Unless Otherwise Noted

## INPUT SPECIFICATIONS:

Input Voltage Range	300V	180-425V
Input Over Voltage Protection	module on	480V
	module off	500V
Under Voltage Lockout	300Vin power up	170V
	300Vin power down	160V
Positive Logic Remote On/Off (note5&6)		
Input Filter		Capacitive

## OUTPUT SPECIFICATIONS:

Voltage Accuracy	±1.0% max.
Transient Response: 25% Step Load Change	<500µs
External Trim Adj. Range (note4)	60-110%
Load Share Accuracy	±10% at 50% to 100% Full Load
Auxiliary Output Voltage/Current	10±3Vdc/20mA max.
Ripple & Noise, 20MHz BW (note3)	
12V	75mV RMS max., 150mV pk-pk max.
24V	120mV RMS max., 240mV pk-pk max.
48V	200mV RMS max., 480mV pk-pk max.
Temperature Coefficient	±0.03%/°C
Short Circuit Protection	Continuous
Line Regulation (note1)	±0.2% max.
Load Regulation (note2)	±0.5% max.
Over Voltage Protection Trip Range, %Vo Nom.	115-140%
Current Limit	105%-125% Nominal Output
Start up Time	40ms typ.

## GENERAL SPECIFICATIONS:

Efficiency	See Table
Isolation Voltage	Input/Output 3000VAC min.
	Input/Case 2500VAC min.
	Output/Case 500VAC min.
Isolation Resistance	10 <sup>7</sup> Ohm min.
Switching Frequency	200KHz typ.
Operating Case Temperature	-40°C to 100°C
Storage Temperature	-55°C to +105°C
Thermal Shutdown, Case Temp.	105°C typ.
Humidity	95% RH max. Non Condensing
MTBF	MIL-HDBK-217F, GB, 25°C, Full Load 420Khrs typ.
Dimensions	4.60x2.40 x0.50 inches (116.8x61.0x12.7 mm)
Case Material	Aluminum Baseplate with Plastic Case
Weight	230g typ.

## NOTE:

1. Measured from high line to low line.
2. Measured from full load to zero load.
3. Output ripple and noise measured with min. capacitor 470uF and 1uF ceramic capacitor across output.
4. The output adjustment circuit and trim equations show as figure1 and figure2.
5. Logic compatibility open collector refer to -Vin
  - Module on >3.5Vdc to 75Vdc or Open Circuit
  - Module off 0 to <1.2Vdc
6. Suffix "N" to the model number with negative logic remote on/off
  - Module on 0 to <1.2Vdc
  - Module off >3.5Vdc to 75Vdc or open circuit
7. An external input capacitor 330uF for all models are recommended to reduce input ripple voltage.

## FB Dimensions:

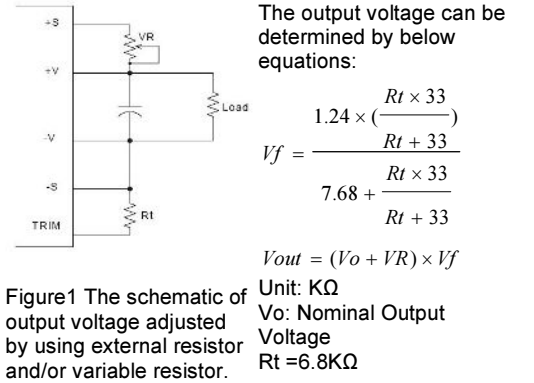
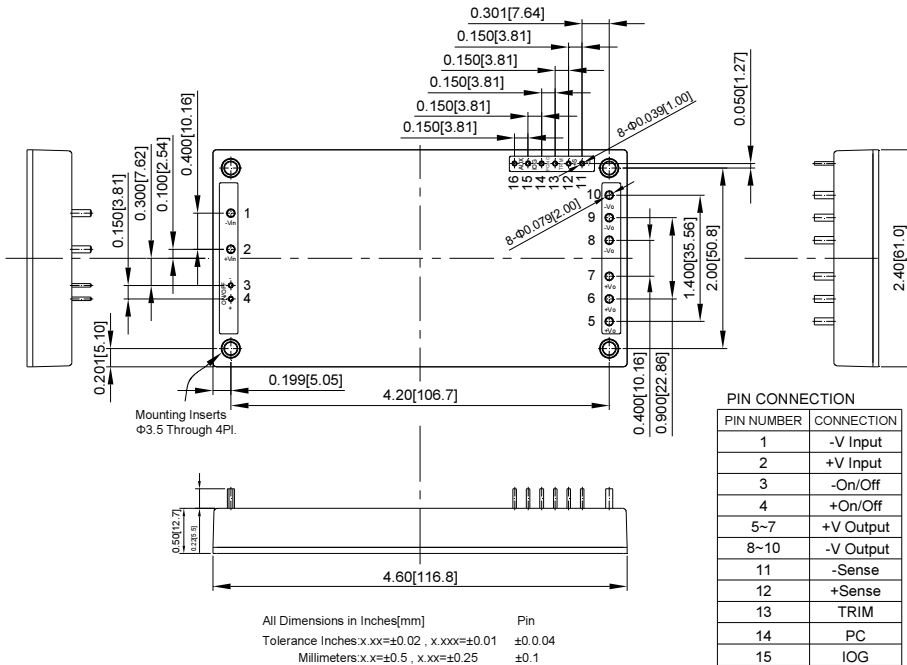

Figure1 The schematic of output voltage adjusted by using external resistor and/or variable resistor.

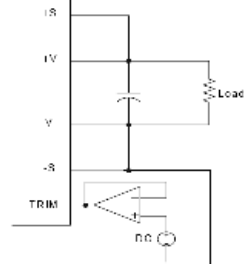

Figure 2 The schematic of output voltage adjusted by using external DC voltage.