

ODS-750

450...750W DC/AC SINE WAVE INVERTER

GENERAL FEATURES:

- Sine wave output voltage
- Selectable output frequency: 50/60Hz
- High input-output isolation 3000Vrms
- Remote inhibit
- Input and output alarm
- Railway version EN50155, RIA12 (optional)
- Fire and smoke: EN45545-2 approved



	12Vdc 9.5 ... 15V	24Vdc 16.8 ... 30V	36Vdc 25.2 ... 45V	48Vdc 33.6 ... 60V	72Vdc 50.4 ... 90V	110Vdc 77 ... 138V
120Vac	ODS-750-7281 450W	ODS-750-7283 750W	ODS-750-7284* 750W	ODS-750-7285 750W	ODS-750-7286 750W	ODS-750-7287 750W
230Vac	ODS-750-7271 450W	ODS-750-7273 750W	ODS-750-7274 750W	ODS-750-7275 750W	ODS-750-7276 750W	ODS-750-7277 750W

*References subject to special MOQs and lead times



INPUT	
Input voltage range	See table
Maximum input ripple	5% Vin nom (Vrms, 100Hz)
OUTPUT	
Output voltage	120 / 230Vac sinusoidal
Output voltage adjustment range	110...120 / 220...230 Vac 120 / 230 Vac (Default) 110 / 220 Vac (Option J)
Load regulation	4%
Line regulation	0.4% @ $\Delta V_{in} -20...+25\%$ 10% @ $\Delta V_{in} -30...+25\%$ 1% @ $\Delta V_{in} -10...+25\%$ for 12Vin models 10% @ $\Delta V_{in} -20...+25\%$ for 12Vin models
Output frequency	50 / 60Hz \pm 0.25Hz
Output wave distortion THD	< 2% (16 samples average)
Output voltage HF ripple	< 20Vpp
ENVIRONMENTAL	
Storage temperature	-40 ... 85°C
Operating temperature full load	-25 ... 55°C (-40 ... 55°C) ⁽²⁾
Operating temperature 50% load	-25 ... 70°C (-40 ... 70°C) ⁽²⁾
Cooling	Variable speed internal fan
MTBF (MIL-HDBK-217-E; G _b , 25°C)	160.000 h
EMC	
Immunity according to	EN61000-6-2 / EN50121-3-2
Emissions according to	EN61000-6-4 / EN50121-3-2
SAFETY	
Safety according to	EN60950
Dielectric strength: Input /output	3000 Vrms / 50Hz / 1min
Dielectric strength: Output / Earth	1500 Vrms / 50Hz / 1min
Dielectric strength: Input / Earth	1500 Vrms / 50Hz / 1min
Fire and smoke	EN45545 approved
MECHANICAL	
Weight	1950 g
Dimensions	130 x 270 x 50mm
PROTECTIONS	
Against input over-currents	Internal fuse for 36, 48, 72, and 110V input models
Against output overloads < 10A	Linear
Against output overloads > 10A	Triggered
Against over-temperature	Shutdown with automatic recovery
CONTROL	
Remote inhibit input	OFF: applying 4...24 Vdc, Impedance >3k3 Ω
Input and output alarm	Isolated contact relay open when alarm (< 0.1A at 150Vcc)

Note ⁽²⁾: The unit can start up and work at an ambient temperature of -40°C with the following restriction: Do not actuate over the connectors below -25°C.



ORDERING CODES

MODEL	DC Input						AC Output					Efficiency Full load [%]
	Voltage				Current		Voltage Default [V]	Current		Power		
	Nom.	Min.	Max.	Max. RIA12	No Load	Max.		Cont.	10ms	Active	Appar.	
	[V]	[V]	[V]	[V]	[A]	[A]	[A]	[W]	[VA]			
ODS-750-7271	12	9.5 ⁽¹⁾	15	-	0.80	55.7	230	2.0	10	450	750	85
ODS-750-7273	24	16.8	30	33.6	0.46	51.9	230	3.26	10	750	750	86
ODS-750-7274	36	25.0	45	50.4	0.36	34.5	230	3.26	10	750	750	87
ODS-750-7275	48	33.6	60	67.2	0.27	25.4	230	3.26	10	750	750	88
ODS-750-7276	72	50.4	90	100.8	0.17	16.9	230	3.26	10	750	750	88
ODS-750-7277	110	77.0	138	154	0.12	11.1	230	3.26	10	750	750	89
ODS-750-7281	12	9.5 ⁽¹⁾	15	-	0.80	56.4	120	3.75	16	450	750	84
ODS-750-7283	24	16.8	30	33.6	0.46	51.9	120	6.26	16	750	750	86
ODS-750-7284*	36	25.0	45	50.4	0.36	34.5	120	6.26	16	750	750	87
ODS-750-7285	48	33.6	60	67.2	0.27	25.4	120	6.26	16	750	750	87
ODS-750-7286	72	50.4	90	100.8	0.17	16.9	120	6.26	16	750	750	87
ODS-750-7287	110	77.0	138	154	0.12	11.1	120	6.26	16	750	750	88

*References subject to special MOQs and lead times

NOTE ⁽¹⁾: Start up voltage ≤ 10.2V. Undervoltage shutdown < 9.5V

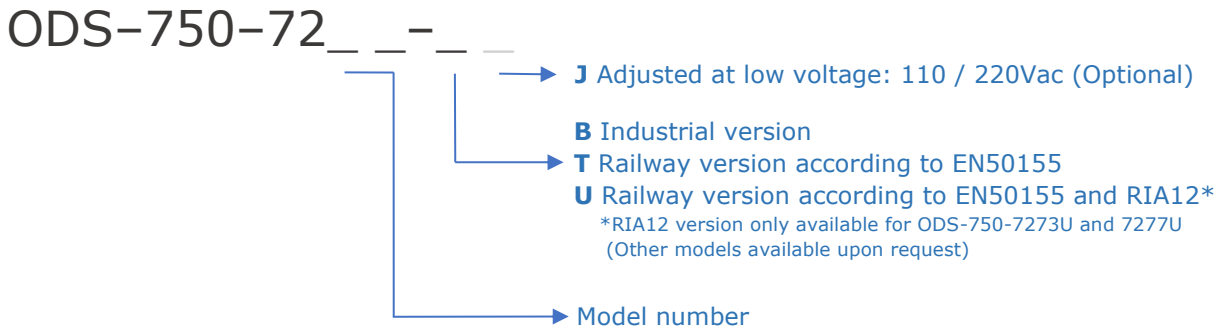

Accessories must be ordered in a separated order line



BLOCKS DIAGRAM

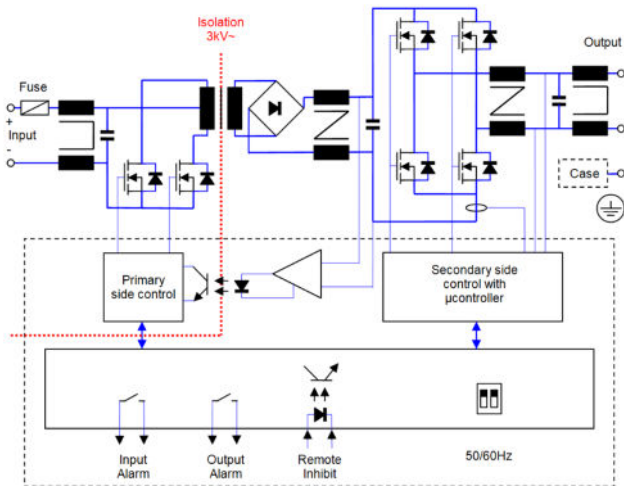

CONNECTIONS

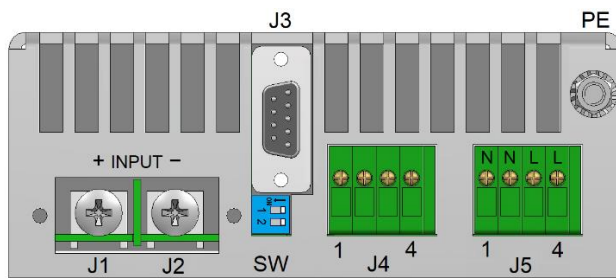

J1	+Vin	Terminals M5	J3 - 1	Input Alarm	DB9
J2	-Vin	Rec. torque 4 Nm	J3 - 2	Input Alarm	
J5 - 1, 2	N Output	Cables up to 2.5mm ²	J3 - 4	Output Alarm	
J5 - 3, 4	L Output		J3 - 5	Output Alarm	
J4 - 1	+ Inhibit		SW - 1	On 60Hz, Off 50Hz	
J4 - 2	- Inhibit		SW - 2	N/A	
J4 - 3, 4	N/C		PE	Stud M5 Rec. torque 3.8 Nm	

POWER DERATING vs AMBIENT TEMPERATURE

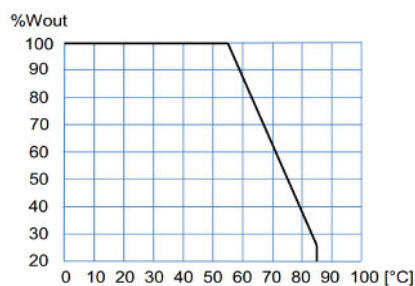

OPERATION CURVE LIMIT

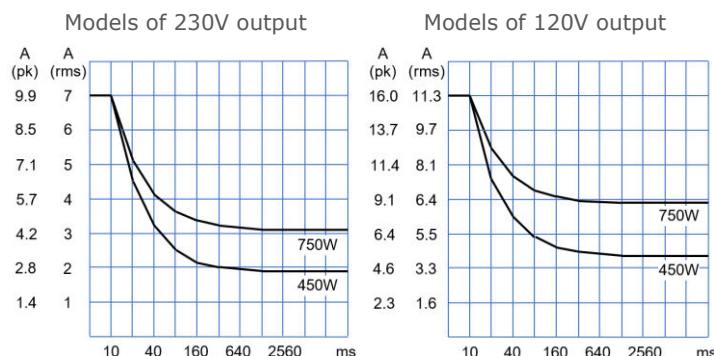

DESCRIPTION

The ODS 750 is a single phase pure sinewave DC-AC inverter with galvanic isolation between input and output.

The following items can be set on the unit:

- The output frequency can be set through the dip-switch 1.
- The unit can be remotely activated or deactivated through the remote inhibit input.

Protections of the ODS-750:

- Reverse polarity protection of the input by fuse.
- Input under voltage: The unit shutdown when the input voltage is below its limit (see the limits on the models table)
- Overloads protection: The output has protection of maximum average power and maximum peak current. The unit shutdowns when the operation curve limit is exceeded for more than one second. Every 2 seconds after shutdown, the unit tries to restart up to 3 times. If the overload persists, the unit remains shutdown until an input reconnection.

INSTALLATION

- The device includes 10 M3 threaded holes that allows different mounting positions. For other mounting solutions see the accessories.
- Make connections as shown in the table.
- The default output frequency is 50Hz. For 60Hz simply actuate the dip-switch as indicated in the figure.
- The inverter includes active overload protection but does not provide protection against prolonged reactive overload conditions. Therefore, the maximum power output (VA) should not be exceeded.
- The EMC output filter is connected to the case, which causes a leakage current lower than 1mA. In order to prevent any touch current, connect the case to earth by means of any mounting hole.

For safety reasons, the following requirements must be met:

- Provide the equipment with some kind of protective enclosure that complies with the electrical safety directives in effect within the country where the equipment is installed.
- Add an external fuse of 60A and 50A for the models of input voltage 12V and 24V respectively.
- Use cables of adequate cross-section to connect inputs and outputs. The following table lists the maximum currents and the minimum cross-sections for the cables used for each power connection.

	Input 12Vcc	Input 24Vcc	Input 36Vcc	Input 48Vcc	Input 72Vcc	Input 110Vcc	Output 120Vca	Output 230Vca
Max. current	60 A	50 A	33A	25 A	17A	12 A	6.7 A	3.5 A
Cable section	10 mm ²	10 mm ²	6 mm ²	2.5 mm ²	2.5 mm ²	1.5 mm ²	1 mm ²	0.75 mm ²



DIMENSIONS

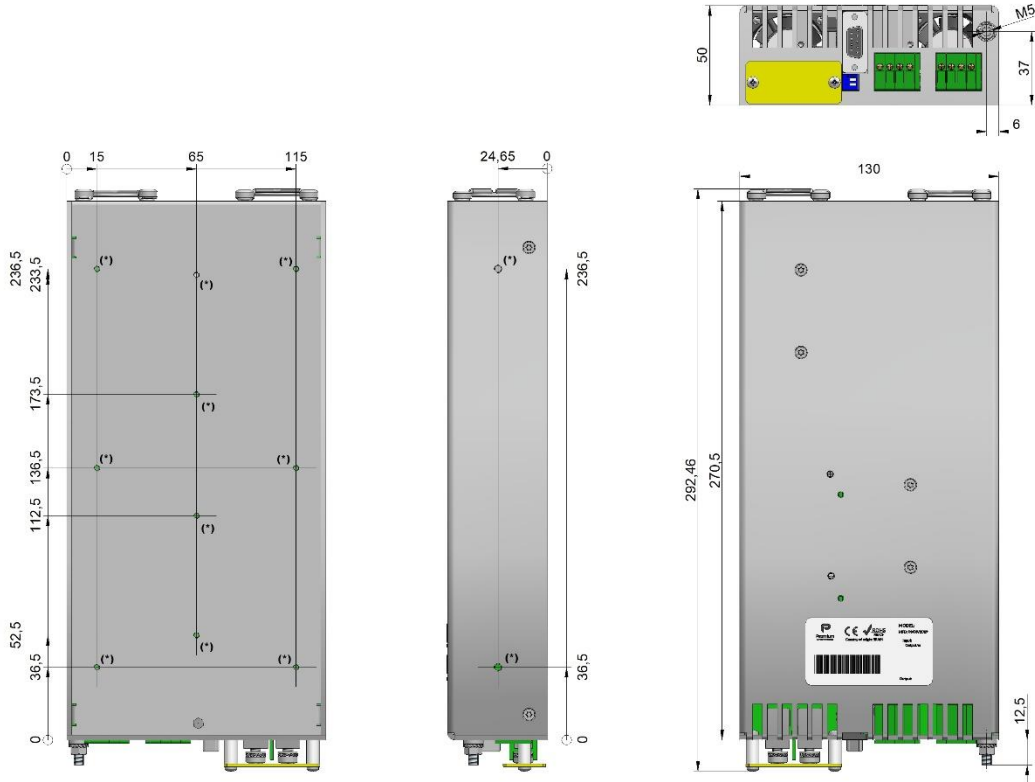

(*) M3 threaded hole. Maximum screw depth: 3mm

ACCESSORIES

ACCESSORIES	NOTES	CODE
DIN RAIL CLIP	Screws included. Order 2 units per inverter	NP-9135
Mounting base	Screws included	NP-9265
Mechanical Interface for subrackof 6U 11Te	Screws included	NP-9366

NP-9135



NP-9265

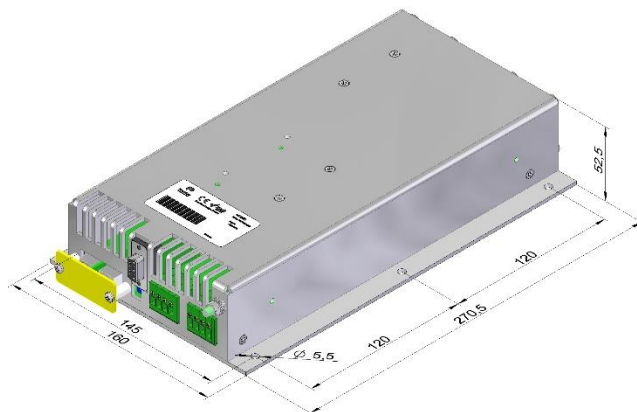

NP-9366

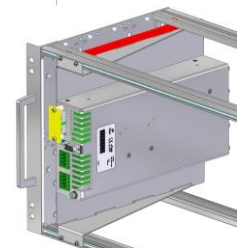
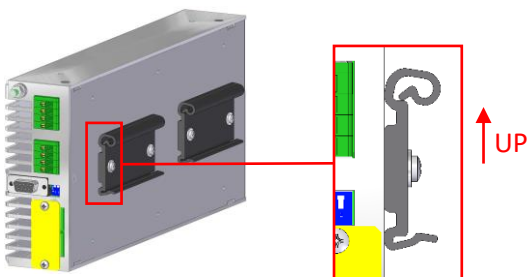
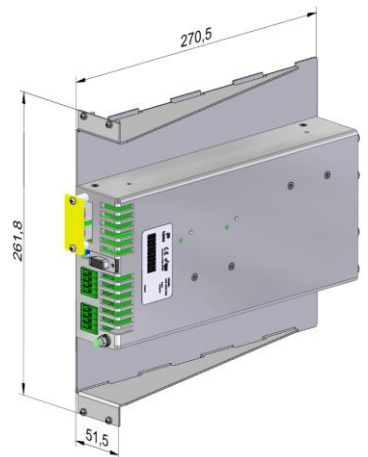



CE|UK CA EU, UKCA DECLARATION OF CONFORMITY

The undersigned, representing the following:

Manufacturer: PREMIUM, S. A.,
Address: C/. Dolors Aleu 19-21, 08908 L'Hospitalet de Llobregat, SPAIN

herewith declares that the product:

Type: DC/AC Inverter
Models: **ODS-750-7071...7087 – ODS-750-7271 ... 7287**

is in conformity with the provisions of the following EU directive(s):

2014/35/EU SI 2016 No 1101	Low voltage / The electrical equipment (safety) regulations
2014/30/EU SI 2016 No 1091	EMC / Electromagnetic compatibility regulations
2015/863/EU SI 2012 No. 3032	RoHS / Restriction of the use of certain hazardous substances in electrical and electronic equipment

and that standards and/or technical specifications referenced below have been applied:

EN 60950: 2005	Safety (Information technology equipment)
EN 62368-1: 2014	Safety. Audio/video, information and communication technology equipment
EN 61000-6-4: 2019	Generic emission standard
EN 61000-6-2: 2019	Generic Immunity standard
EN 50155: 2017*	Railway applications. Electronic equipment used on rolling stock material
EN 50121-3-2: 2016*	Railway applications. EMC Rolling stock equipment
EN 50121-4: 2016*	Railway applications. EMC of the signalling and telecommunications apparatus
RIA-12*	Protection of electronic equipment from transients & surges in DC Control Systems

* Optional, see annexe

CE marking year: **2006**; UKCA marking year: **2021**

Notes:

For the fulfilment of this declaration the product must be used only for the aim that has been conceived, considering the limitations established in the instructions manual or datasheet.

L'Hospitalet de Llobregat, 18-07-2023

Albert Sole
Technical Director

PREMIUM S.A. is an ISO9001 and ISO14001
certified company by **Bureau Veritas**

ANNEXE

Applicable values for the different sections of the norm EN50155: 2017																																																																									
4.3.1	Working altitude	Up to 1800m																																																																							
4.3.2	Ambient temperature	Class OT1 (-25 to 55°C): load < 100% Class OT2 (-40 to 55°C): load < 100% (Without connectors handling) Class OT3 (-25 to 70°C): load < 50% Class OT4 (-40 to 70°C): load < 50% (Without Connectors handling)																																																																							
4.3.3	Switch-on extended operating temp.	ST1																																																																							
4.3.4	Rapid temperature variations	H1																																																																							
4.3.5	Shocks and vibrations	According EN61373:2010 Category 1 class B																																																																							
4.3.6	EMC Electromagnetic Compatibility EN50121-3-2:2016	<table border="1"> <thead> <tr> <th>Test</th> <th>Norm</th> <th>Port</th> <th>Frequency</th> <th>Limits</th> </tr> </thead> <tbody> <tr> <td rowspan="4">Radiated emissions</td> <td rowspan="4">IEC55016</td> <td rowspan="4">Case</td> <td>30MHz...230MHz</td> <td>40dB(µV/m) Qpk at 10m</td> </tr> <tr> <td>230MHz...1GHz</td> <td>47dB(µV/m) Qpk at 10m</td> </tr> <tr> <td>1...3GHz</td> <td>Do not apply</td> </tr> <tr> <td>3...6GHz</td> <td>Internal freq. < 108MHz</td> </tr> <tr> <td rowspan="2">Conducted emissions</td> <td rowspan="2">IEC55016</td> <td rowspan="2">Input</td> <td>150kHz...500kHz</td> <td>99dB(µV) Qpk</td> </tr> <tr> <td>500kHz...30MHz</td> <td>93dB(µV) Qpk</td> </tr> </tbody> </table>	Test	Norm	Port	Frequency	Limits	Radiated emissions	IEC55016	Case	30MHz...230MHz	40dB(µV/m) Qpk at 10m	230MHz...1GHz	47dB(µV/m) Qpk at 10m	1...3GHz	Do not apply	3...6GHz	Internal freq. < 108MHz	Conducted emissions	IEC55016	Input	150kHz...500kHz	99dB(µV) Qpk	500kHz...30MHz	93dB(µV) Qpk																																																
		Test	Norm	Port	Frequency	Limits																																																																			
		Radiated emissions	IEC55016	Case	30MHz...230MHz	40dB(µV/m) Qpk at 10m																																																																			
					230MHz...1GHz	47dB(µV/m) Qpk at 10m																																																																			
					1...3GHz	Do not apply																																																																			
					3...6GHz	Internal freq. < 108MHz																																																																			
		Conducted emissions	IEC55016	Input	150kHz...500kHz	99dB(µV) Qpk																																																																			
					500kHz...30MHz	93dB(µV) Qpk																																																																			
		<table border="1"> <thead> <tr> <th>Test</th> <th>Norm</th> <th>Port</th> <th>Severity</th> <th>Conditions</th> <th>P</th> </tr> </thead> <tbody> <tr> <td rowspan="2">Electrostatic discharge</td> <td rowspan="2">IEC61000-4-2</td> <td rowspan="2">Case</td> <td>±8kV</td> <td>Air (isolated parts)</td> <td>B</td> </tr> <tr> <td>±8kV</td> <td>Contact (conductive parts)</td> <td></td> </tr> <tr> <td rowspan="4">Radiated high-frequency</td> <td rowspan="4">IEC61000-4-3</td> <td rowspan="4">X/Y/Z Axis</td> <td>20V/m</td> <td>0.08...1.0GHz M. 80% 1kHz</td> <td rowspan="4">A</td> </tr> <tr> <td>10V/m</td> <td>1.4...2.1GHz M. 80% 1kHz</td> </tr> <tr> <td>5V/m</td> <td>2.1...2.5GHz M. 80% 1kHz</td> </tr> <tr> <td>3V/m</td> <td>5.1...6Ghz M. 80% 1kHz</td> </tr> <tr> <td rowspan="4">Fast transients</td> <td rowspan="4">IEC61000-4-4</td> <td>Input</td> <td>±2kV</td> <td rowspan="4">Tr/Th: 5/50 ns</td> <td rowspan="4">A</td> </tr> <tr> <td>Output</td> <td>±2kV</td> </tr> <tr> <td>Signal</td> <td>±2kV</td> </tr> <tr> <td>PE</td> <td>±1kV</td> </tr> <tr> <td rowspan="2">Surge</td> <td rowspan="2">IEC61000-4-5</td> <td>Input L to L</td> <td>±1kV</td> <td rowspan="2">Tr/Th: 1.2/50µs</td> <td rowspan="2">B</td> </tr> <tr> <td>Input L to PE</td> <td>±2kV</td> </tr> <tr> <td rowspan="4">Conducted RF</td> <td rowspan="4">IEC61000-4-6</td> <td>Input</td> <td>10V</td> <td rowspan="4">0.15...80MHz M. 80% 1kHz</td> <td rowspan="4">A</td> </tr> <tr> <td>Output</td> <td>10V</td> </tr> <tr> <td>Signal</td> <td>10V</td> </tr> <tr> <td>PE</td> <td>10V</td> </tr> <tr> <td>Magnetic field</td> <td>IEC61000-4-8</td> <td>X/Y/Z Axis</td> <td>300A/m</td> <td>0Hz, 16.7Hz, 50/60Hz</td> <td>A</td> </tr> <tr> <td>Pulse magnetic field</td> <td>IEC61000-4-9</td> <td>X/Y/Z Axis</td> <td>300A/m</td> <td>Tr/Th: 6.4/16µs</td> <td>B</td> </tr> </tbody> </table>	Test	Norm	Port	Severity	Conditions	P	Electrostatic discharge	IEC61000-4-2	Case	±8kV	Air (isolated parts)	B	±8kV	Contact (conductive parts)		Radiated high-frequency	IEC61000-4-3	X/Y/Z Axis	20V/m	0.08...1.0GHz M. 80% 1kHz	A	10V/m	1.4...2.1GHz M. 80% 1kHz	5V/m	2.1...2.5GHz M. 80% 1kHz	3V/m	5.1...6Ghz M. 80% 1kHz	Fast transients	IEC61000-4-4	Input	±2kV	Tr/Th: 5/50 ns	A	Output	±2kV	Signal	±2kV	PE	±1kV	Surge	IEC61000-4-5	Input L to L	±1kV	Tr/Th: 1.2/50µs	B	Input L to PE	±2kV	Conducted RF	IEC61000-4-6	Input	10V	0.15...80MHz M. 80% 1kHz	A	Output	10V	Signal	10V	PE	10V	Magnetic field	IEC61000-4-8	X/Y/Z Axis	300A/m	0Hz, 16.7Hz, 50/60Hz	A	Pulse magnetic field	IEC61000-4-9	X/Y/Z Axis	300A/m	Tr/Th: 6.4/16µs	B
		Test	Norm	Port	Severity	Conditions	P																																																																		
		Electrostatic discharge	IEC61000-4-2	Case	±8kV	Air (isolated parts)	B																																																																		
					±8kV	Contact (conductive parts)																																																																			
		Radiated high-frequency	IEC61000-4-3	X/Y/Z Axis	20V/m	0.08...1.0GHz M. 80% 1kHz	A																																																																		
					10V/m	1.4...2.1GHz M. 80% 1kHz																																																																			
5V/m	2.1...2.5GHz M. 80% 1kHz																																																																								
3V/m	5.1...6Ghz M. 80% 1kHz																																																																								
Fast transients	IEC61000-4-4	Input	±2kV	Tr/Th: 5/50 ns	A																																																																				
		Output	±2kV																																																																						
		Signal	±2kV																																																																						
		PE	±1kV																																																																						
Surge	IEC61000-4-5	Input L to L	±1kV	Tr/Th: 1.2/50µs	B																																																																				
		Input L to PE	±2kV																																																																						
Conducted RF	IEC61000-4-6	Input	10V	0.15...80MHz M. 80% 1kHz	A																																																																				
		Output	10V																																																																						
		Signal	10V																																																																						
		PE	10V																																																																						
Magnetic field	IEC61000-4-8	X/Y/Z Axis	300A/m	0Hz, 16.7Hz, 50/60Hz	A																																																																				
Pulse magnetic field	IEC61000-4-9	X/Y/Z Axis	300A/m	Tr/Th: 6.4/16µs	B																																																																				
P= Performance criteria, L= Line, PE= Protective Earth																																																																									
4.3.7	Relative humidity	Up to 95%																																																																							
5.1.1.2	DC power supply range	From 0.70 to 1.25 Un continuous																																																																							
5.1.1.3	Temporary DC power supply fluctuation	From 0.60 to 1.40 Un 0.1s From 1.25 to 1.40 Un 1s without damage																																																																							
5.1.1.4	Interruptions of voltage supply	Class S1 (without interruptions)																																																																							
5.1.1.6	Input ripple factor	10% peak to peak with a DC Ripple Factor of 5 %																																																																							
5.1.3	Supply change-over	0,6 Un duration 100 ms (without interruptions). Performance criterion A																																																																							
7.2.7	Input reverse polarity protection	By serial diode in the input																																																																							
10.7	Protective coating for PCB assemblies	Class PC2																																																																							
13.3	Tests list	<table border="0"> <tr><td>1 Visual Inspection</td><td>Routine</td></tr> <tr><td>2 Performance test</td><td>Routine</td></tr> <tr><td>3 Power supply test</td><td>Routine</td></tr> <tr><td>4 Insulation test</td><td>Routine</td></tr> <tr><td>5 Low temperature storage test</td><td>-</td></tr> <tr><td>6 Low temperature start-up test</td><td>Type</td></tr> <tr><td>7 Dry heat test</td><td>Type</td></tr> <tr><td>8 Cyclic damp heat test</td><td>Type</td></tr> <tr><td>9 Salt mist test</td><td>-</td></tr> <tr><td>10 Enclosure protection test (IP code)</td><td>-</td></tr> <tr><td>11 EMC test</td><td>Type</td></tr> <tr><td>12 Shocks and vibrations test</td><td>Type</td></tr> <tr><td>13 Equipment stress screening test</td><td>Routine: 24h at 40°C and load 100%</td></tr> <tr><td>14 Rapid Temperature variation test</td><td>Type</td></tr> </table>	1 Visual Inspection	Routine	2 Performance test	Routine	3 Power supply test	Routine	4 Insulation test	Routine	5 Low temperature storage test	-	6 Low temperature start-up test	Type	7 Dry heat test	Type	8 Cyclic damp heat test	Type	9 Salt mist test	-	10 Enclosure protection test (IP code)	-	11 EMC test	Type	12 Shocks and vibrations test	Type	13 Equipment stress screening test	Routine: 24h at 40°C and load 100%	14 Rapid Temperature variation test	Type																																											
1 Visual Inspection	Routine																																																																								
2 Performance test	Routine																																																																								
3 Power supply test	Routine																																																																								
4 Insulation test	Routine																																																																								
5 Low temperature storage test	-																																																																								
6 Low temperature start-up test	Type																																																																								
7 Dry heat test	Type																																																																								
8 Cyclic damp heat test	Type																																																																								
9 Salt mist test	-																																																																								
10 Enclosure protection test (IP code)	-																																																																								
11 EMC test	Type																																																																								
12 Shocks and vibrations test	Type																																																																								
13 Equipment stress screening test	Routine: 24h at 40°C and load 100%																																																																								
14 Rapid Temperature variation test	Type																																																																								

Applicable values for the different sections of the norm RIA12



	Type of disturbance	Voltage level	Duration	Source impedance
5.2	Supply related surge	3.5 x Vin nom 1.5 x Vin nom	20 ms 1 s	0.2 Ω 0.2 Ω
5.3	Direct transient	800 V 1500 V 3000 V 4000 V 7000 V	100 μs 50 μs 5 μs 1 μs 0.1 μs	5 Ω 5 Ω 100 Ω 100 Ω 100 Ω
5.4	Indirect coupled transient	1500 V 3000 V 4000 V 7000 V	50 μs 5 μs 1 μs 0.1 μs	100 Ω 100 Ω 100 Ω 100 Ω