



# CQB50W12 Series Application Note V12

## ISOLATED DC-DC CONVERTER CQB50W12 SERIES APPLICATION NOTE



### Approved By:

Department	Approved By	Checked By	Written By
Research and Development Department	Enoch	Danny/Wade	Joyce
		Jacky	
Quality Assurance Department	Ryan	Benny	



# CQB50W12 Series Application Note V12

## Contents

1. Introduction .....	3
2. Pin Function Description .....	3
3. Connection for Standard Use .....	4
4. Test Set-Up .....	4
5. Recommend Layout, PCB Footprint and Soldering Information.....	4
6. Features and Functions.....	5
6.1 UVLO (Under Voltage Lock Out) .....	5
6.2 Over Current / Short Circuit Protection .....	5
6.3 Output Over Voltage Protection .....	5
6.4 Over Temperature Protection.....	6
6.5 Remote On/Off.....	6
6.6 Output Remote Sensing.....	6
6.7 Output Voltage Adjustment .....	7
7. Input / Output Considerations.....	8
7.1 Input Capacitance at the Power Module .....	8
7.2 Hold Up Time .....	8
7.3 Output Ripple and Noise.....	9
7.4 Output Capacitance .....	9
8. Series and Parallel Operation .....	9
8.1 Series Operation .....	9
8.2 Parallel Operation .....	10
8.3 Redundant Operation.....	10
9. Thermal Design .....	11
9.1 Operating Temperature Range .....	11
9.2 Convection Requirements for Cooling .....	11
9.3 Thermal Considerations.....	11
9.4 Power Derating .....	11
9.5 Quarter Brick Heat Sinks:.....	13
10. Safety & EMC.....	14
10.1 Input Fusing and Safety Considerations.....	14
10.2 EMC Considerations .....	14
10.3 Suggested Configuration for RIA12 Surge Test .....	20



# CQB50W12 Series Application Note V12

## 1. Introduction

The CQB50W12 series of DC-DC converters offers 30-50 watts of output power @ single output voltages of 5, 12, 24, 48VDC with industry standard quarter-brick. It has a wide (12:1) input voltage range of 14 to 160VDC (72VDC nominal) and 3000VDC basic isolation.

Compliant with EN50155, EN45545, EN50121-3-2. High efficiency up to 89%, allowing case operating temperature range of  $-40^{\circ}\text{C}$  to  $100^{\circ}\text{C}$ . An optional heat sink is available to extend the full power range of the unit. Very low no load power consumption (5mA), an ideal solution for energy critical systems.

The standard control functions include remote on/off (positive or negative) and +10%, -20% adjustable output voltage.

Fully protected against input UVLO (under voltage lock out), output over-current, output over-voltage and over-temperature and continuous short circuit conditions.

CQB50W12 series is designed primarily for common railway applications of 24V, 36V, 48V, 72V, 96V, 110V nominal voltage and also suitable for distributed power architectures, telecommunications, battery operated equipment and industrial applications.

## 2. Pin Function Description

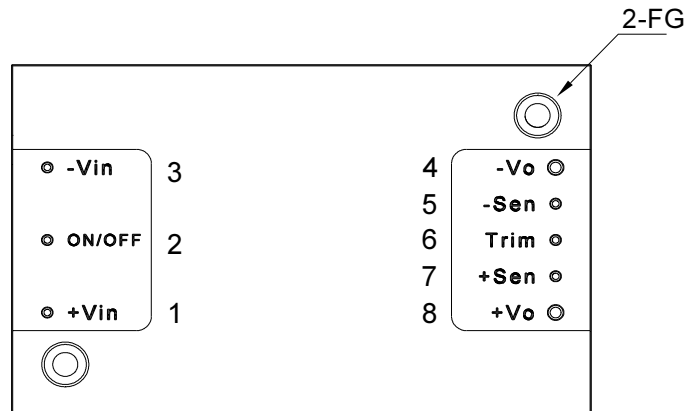

No	Label	Function	Description	Reference
1	+Vin	+V Input	Positive Supply Input	<b>Section 7.1/7.2</b>
2	ON/OFF	On/Off	External Remote On/Off Control	<b>Section 6.5</b>
3	-Vin	-V Input	Negative Supply Input	<b>Section 7.1/7.2</b>
4	-Vo	-V Output	Negative Power Output	<b>Section 7.3/7.4</b>
5	-Sen	-Sense	Negative Output Remote Sense	<b>Section 6.6</b>
6	Trim	Trim	External Output Voltage Adjustment	<b>Section 6.7</b>
7	+Sen	+Sense	Positive Output Remote Sense	<b>Section 6.6</b>
8	+Vo	+V Output	Positive Power Output	<b>Section 7.3/7.4</b>
--	--	Mounting Insert	Mounting Insert (FG)	<b>Section 9.5/10.2</b>

Note: Base plate can be connected to FG through M3 threaded mounting insert. Recommended torque 3Kgf-cm.



# CQB50W12 Series Application Note V12

## 3. Connection for Standard Use

The connection for standard use is shown below. An external input capacitor (C1) 82uF for all models is recommended to reduce input ripple voltage. External output capacitors (C2, C3) are recommended to reduce output ripple and noise, 22uF aluminum solid and 1uF ceramic capacitor for all models.

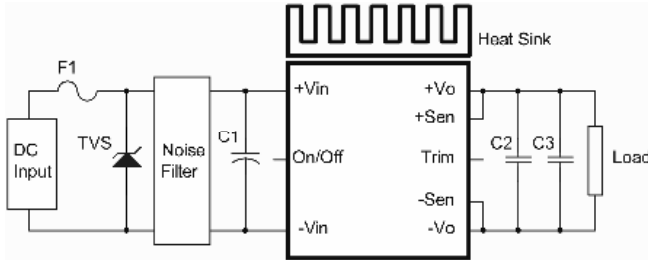

Symbol	Component	Reference
F1, TVS	Input fuse, TVS	<b>Section 10.1</b>
C1	External capacitor on input side	<b>Note</b> <b>Section 7.2</b>
C2, C3	External capacitor on the output side	<b>Section 7.3/7.4</b>
Noise Filter	External input noise filter	<b>Section 10.2</b>
Remote On/Off	External Remote On/Off control	<b>Section 6.5</b>
Trim	External output voltage adjustment	<b>Section 6.7</b>
Heat sink	External heat sink	<b>Section 9.2/9.3/9.4/9.5</b>
+Sense/-Sense	--	<b>Section 6.6</b>

### Note:

If the impedance of input line is high, C1 capacitance must be more than above. Use more than two recommended capacitor above in parallel when ambient temperature becomes lower than -20 °C.

## 4. Test Set-Up

The basic test set-up to measure parameters such as efficiency and load regulation is shown below. When testing the modules under any transient conditions please ensure that the transient response of the source is sufficient to power the equipment under test. We can calculate:

- Efficiency
- Load regulation and line regulation

The value of efficiency is defined as:

$$\eta = \frac{V_o \times I_o}{V_{in} \times I_{in}} \times 100\%$$

Where:

- $V_o$  is output voltage,
- $I_o$  is output current,
- $V_{in}$  is input voltage,
- $I_{in}$  is input current.

The value of load regulation is defined as:

$$Load\ reg. = \frac{V_{FL} - V_{NL}}{V_{NL}} \times 100\%$$

Where:

- $V_{FL}$  is the output voltage at full load.
- $V_{NL}$  is the output voltage at no load.

The value of line regulation is defined as:

$$Line\ reg. = \frac{V_{HL} - V_{LL}}{V_{LL}} \times 100\%$$

Where:

- $V_{HL}$  is the output voltage of maximum input voltage at full load.
- $V_{LL}$  is the output voltage of minimum input voltage at full load.

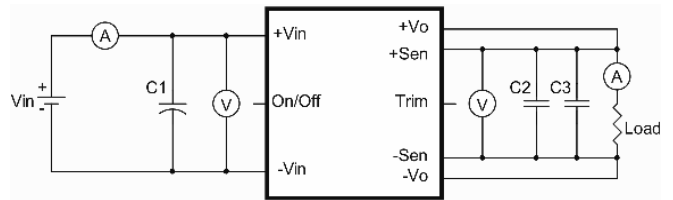

CQB50W12 Series Test Setup

C1: 82uF/250V ESR<0.7Ω

C2: 1uF/1206 ceramic capacitor

C3: 22uF aluminum solid capacitor

## 5. Recommend Layout, PCB Footprint and Soldering Information

The system designer or end user must ensure that metal and other components in the vicinity of the converter meet the spacing requirements for which the system is approved. Low resistance and inductance PCB layout traces are the norm and should be used where possible. Due consideration must also be given to proper low impedance tracks between power module, input and output grounds.

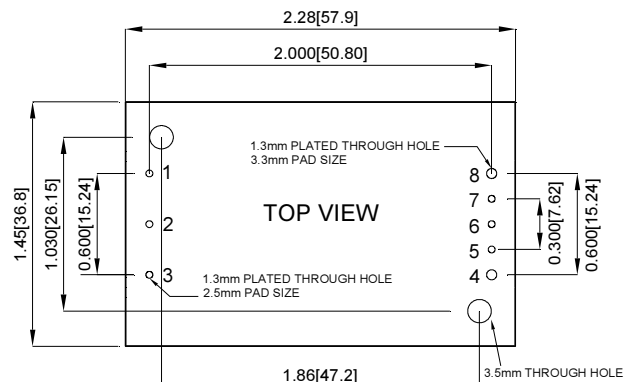



# CQB50W12 Series Application Note V12

Clean the soldered side of the module with a brush, prevent liquid from getting into the module. Do not clean by soaking the module into liquid. Do not allow solvent to come in contact with product labels or resin case as this may change the color of the resin case or cause deletion of the letters printed on the product label. After cleaning, dry the modules well.

The suggested soldering iron is 450°C for up to 5 seconds (less than 50W). Furthermore, the recommended soldering profile is shown below, and PCB layout is referring to Section 10.2.

Lead Free Wave Soldering Profile

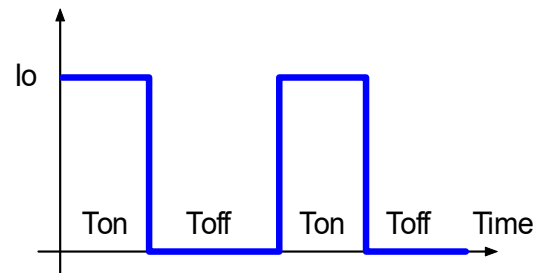
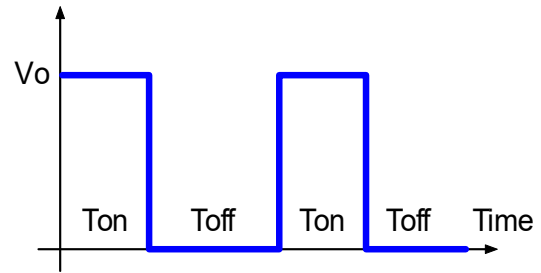
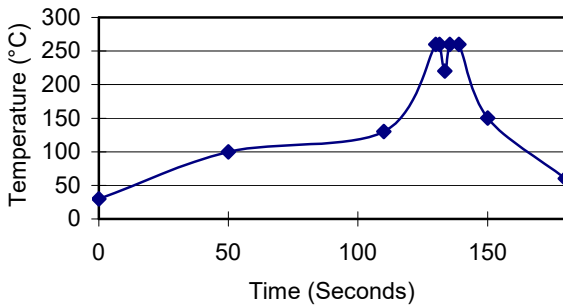

## 6. Features and Functions

### 6.1 UVLO (Under Voltage Lock Out)

Input under voltage lockout is standard on the CQB50W12 series unit. The unit will shut down when the input voltage drops below a threshold, and the unit will operate when the input voltage goes above the upper threshold.

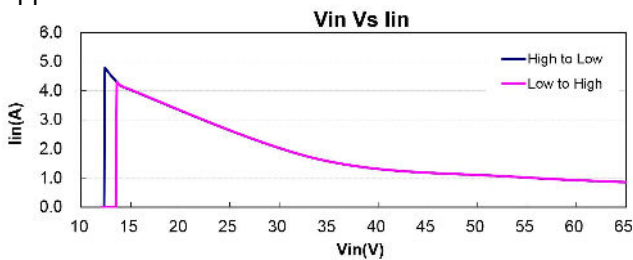

### 6.2 Over Current / Short Circuit Protection

All models have internal over current and continuous short circuit protection. The unit operates normally once the fault condition is removed. At the point of current limit inception, the converter will go into hiccup mode protection.

### 6.3 Output Over Voltage Protection

The output over voltage protection consists of circuitry that internally limits the output voltage. If more accurate output over voltage protection is required, then an external circuit can be used via the remote on/off pin.

**Note:** Please note that device inside the power supply might fail when voltage more than rated output voltage is applied to output pin. This could happen when the customer tests the over voltage protection of unit. OVP can be tested by using the TRIM Up function. Consult us for more information.



# CQB50W12 Series Application Note V12

## 6.4 Over Temperature Protection

These modules have an over temperature protection circuit to safeguard against thermal damage. Shutdown occurs with the maximum case reference temperature is exceeded. The module will restart when the case temperature falls below over temperature recovery threshold. Please measure case temperature of the center part of aluminum base plate.

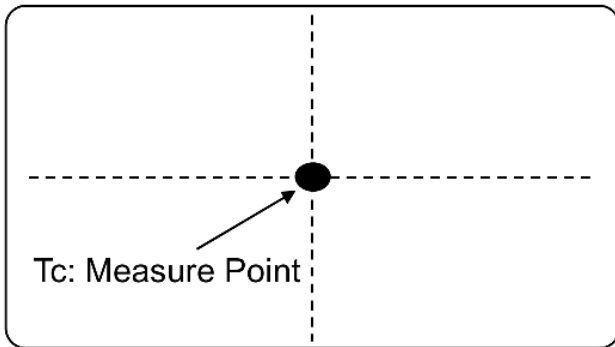
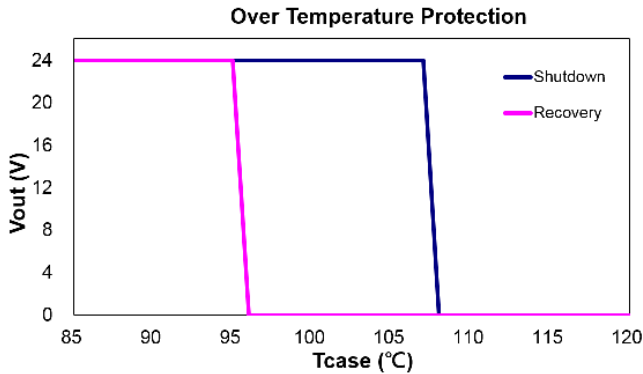

## 6.5 Remote On/Off

The CQB50W12 series allows the user to switch the module on and off electronically with the remote On/Off feature. All models are available in “positive logic” and “negative logic” (optional) versions. The converter turns on if the remote On/Off pin is high (>3.5Vdc to 160Vdc or open circuit). Setting the pin low (0 to <1.2Vdc) will turn the converter off. The signal level of the remote On/Off input is defined with respect to ground. If not using the remote On/Off pin, leave the pin open (converter will be on).

Models with part number suffix “N” are the “negative logic” remote On/Off version. The unit turns off if the remote On/Off pin is high (>4.0Vdc to 160Vdc or open circuit). The converter turns on if the On/Off pin input is low (0 to <1.2Vdc). Note that the converter is off by default.

Logic State (Pin 2)	Negative Logic	Positive Logic
Logic Low	Module on	Module off
Logic High	Module off	Module on

The converter remote On/Off circuit built-in on input side. The ground pin of input side Remote On/Off circuit is -Vin pin. Inside connection sees below.

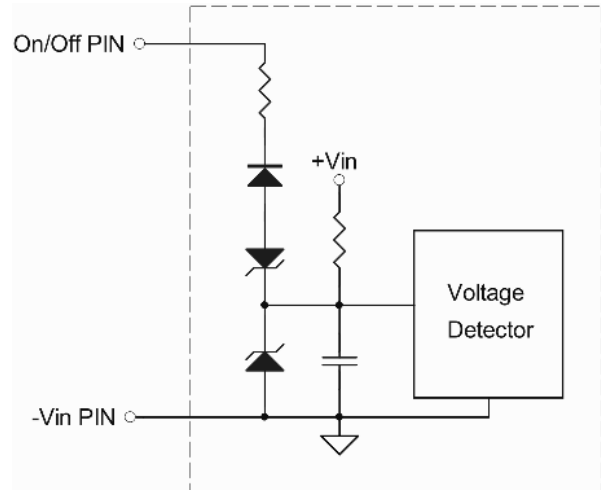

Connection examples see below.

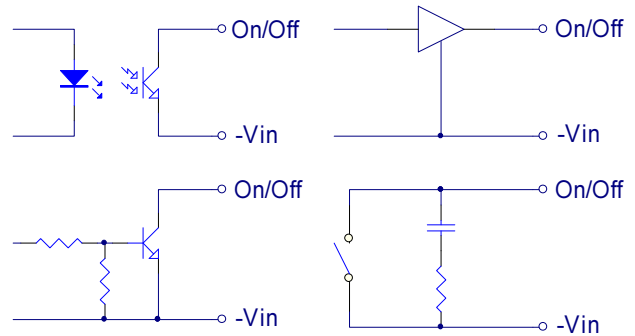

Remote On/Off Connection Example

## 6.6 Output Remote Sensing

The CQB50W12 series converter has the capability to remotely sense both lines of its output. This feature moves the effective output voltage regulation point from the output of the unit to the point of connection of the remote sense pins. This feature automatically adjusts the real output voltage of the CQB50W12 series in order to compensate for voltage drops in distribution and maintain a regulated voltage at the point of load. The remote-sense voltage range is:

$$[(+V_{out}) - (-V_{out})] - [(+Sense) - (-Sense)] \leq 10\% \text{ of } V_{o\_nominal}$$

When remote sense is in use, the sense should be connected by twisted-pair wire or shield wire. If the sensing patterns short, heavy current flows and the pattern may be damaged. Output voltage might become unstable because of impedance of wiring and load condition when length of wire is exceeding 400mm. This is shown in the schematic below.



# CQB50W12 Series Application Note V12

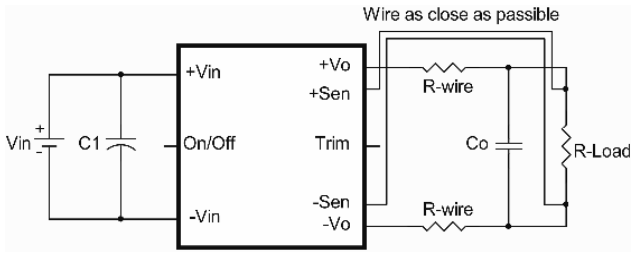

If the remote sense feature is not to be used, the sense pins should be connected locally. The +Sense pin should be connected to the +Vout pin at the module and the -Sense pin should be connected to the -Vout pin at the module. Wire between +Sense and +Vout and between -Sense and -Vout as short as possible. Loop wiring should be avoided. The converter might become unstable by noise coming from poor wiring. This is shown in the schematic below.

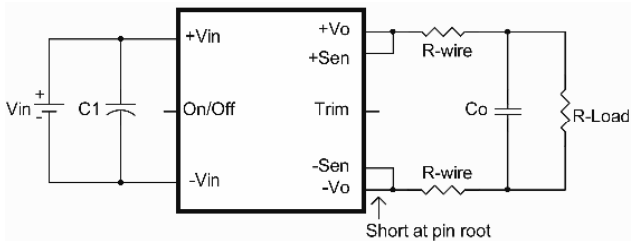

**Note:** Although the output voltage can be varied (increased or decreased) by both remote sense and trim, the maximum variation for the output voltage is the larger of the two values not the sum of the values. The output power delivered by the module is defined as the voltage at the output terminals multiplied by the output current. Using remote sense and trim can cause the output voltage to increase and consequently increase the power output of the module if output current remains unchanged. Always ensure that the output power of the module remains at or below the maximum rated power. Also be aware that if  $V_{o,set}$  is below nominal value,  $P_{out,max}$  will also decrease accordingly because  $I_{o,max}$  is an absolute limit. Thus,  $P_{out,max} = V_{o,set} \times I_{o,max}$  is also an absolute limit.

## 6.7 Output Voltage Adjustment

Output may be externally trimmed (-20% to +10%) with a fixed resistor or an external trim pot as shown (optional). Model specific formulas for calculating trim resistors are available upon request as a separate document.

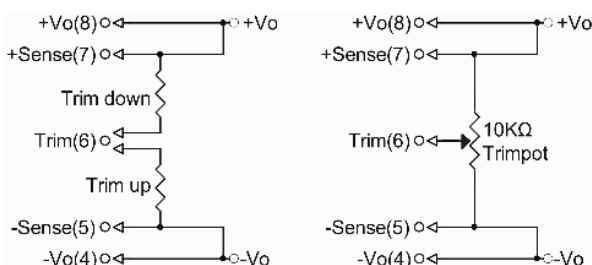

In order to trim the voltage up or down, one needs to connect the trim resistor either between the trim pin and -Sense for trim-up or between trim pin and +Sense for trim-down. The output voltage trim range is -20% to +10%. This is shown:

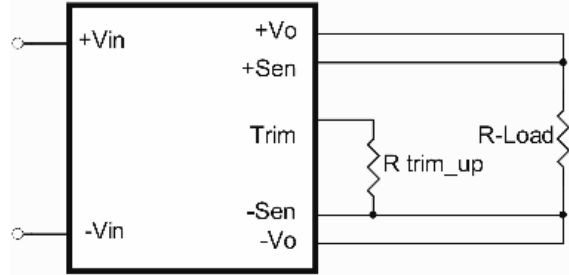

Trim-up Voltage Setup

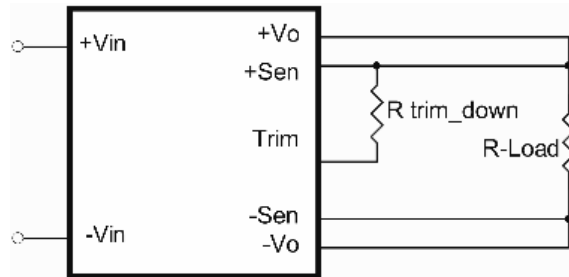

Trim-down Voltage Setup

The value of  $R_{trim\_up}$  defined as:

$$R_{trim\_up} = \left[ \frac{R1(V_T - V_f \left( \frac{R2}{R2+R3} \right))}{V_o - V_{o,nom}} \right] - \frac{R2 \times R3}{R2+R3} \text{ (K}\Omega\text{)}$$

Where:

$R_{trim\_up}$  is the external resistor in K $\Omega$ .

$V_{o,nom}$  is the nominal output voltage.

$V_o$  is the desired output voltage.

$R1, R2, R3$  and  $V_r$  are internal to the unit and are defined in Table 1.

Table 1 – Trim up and Trim down Resistor Values

Model Number	Output Voltage(V)	R1 (K $\Omega$ )	R2 (K $\Omega$ )	R3 (K $\Omega$ )	Vr (V)	Vf (V)
CQB50W12-72S05	5.0	3	6.8	2.4	1.24	0.5
CQB50W12-72S12	12.0	9.1	24	5.1	2.5	0.5
CQB50W12-72S24	24.0	20	68	7.5	2.5	0.5
CQB50W12-72S48	48.0	36	82	5.1	2.5	0.5

For example, to trim-up the output voltage of 12V module (CQB50W12-72S12) by 5% to 12.6V,  $R_{trim\_up}$  is calculated as follows:

$$V_o - V_{o,nom} = 12.6 - 12 = 0.6V$$

$$R1 = 9.1 \text{ K}\Omega, R2 = 24 \text{ K}\Omega, R3 = 5.1 \text{ K}\Omega,$$

$$V_r = 2.5 \text{ V}, V_f = 0.5 \text{ V}$$

$$R_{trim\_up} = \frac{18.997}{0.6} - 4.206 = 27.45 \text{ (K}\Omega\text{)}$$



# CQB50W12 Series Application Note V12

## The typical value of $R_{trim\_up}$

Trim up (%)	5V	12V	24V	48V
	$R_{trim\_up}$ (K $\Omega$ )			
1%	50.45	154.1	164.0	147.3
2%	24.34	74.95	78.64	71.29
3%	15.63	48.56	50.18	45.93
4%	11.28	35.37	35.94	33.24
5%	8.67	27.45	27.40	25.63
6%	6.93	22.17	21.71	20.56
7%	5.69	18.41	17.64	16.94
8%	4.75	15.58	14.59	14.22
9%	4.03	13.38	12.22	12.10
10%	3.45	11.62	10.32	10.41

## The value of $R_{trim\_down}$ defined as:

$$R_{trim\_down} = \frac{R1 \times (V_o - V_r)}{V_{o,nom} - V_o} - R2 \text{ (K}\Omega\text{)}$$

Where:

$R_{trim\_down}$  is the external resistor in K $\Omega$ .

$V_{o,nom}$  is the nominal output voltage.

$V_o$  is the desired output voltage.

$R1$ ,  $R2$  and  $V_r$  are internal to the unit and are defined in Table 1.

For example: to trim-down the output voltage of 12V module (CQB50W12-72S12) by 5% to 11.4V,  $R_{trim\_down}$  is calculated as follows:

$$V_{o,nom} - V_o = 12 - 11.4 = 0.6 \text{ V}$$

$$R1 = 9.1 \text{ K}\Omega, R2 = 51 \text{ K}\Omega, V_r = 2.5 \text{ V}$$

$$R_{trim\_down} = \frac{9.1 \times (11.4 - 2.5)}{0.6} - 2.4 = 110.98 \text{ (K}\Omega\text{)}$$

## The typical value of $R_{trim\_down}$

Trim down (%)	5V	12V	24V	48V
	$R_{trim\_down}$ (K $\Omega$ )			
1%	215.8	687.3	1703	3294
2%	103.0	327.1	807.8	1588
3%	65.40	207.0	509.2	1019
4%	46.60	147.0	359.9	735.1
5%	35.32	110.9	270.3	564.5
6%	27.80	86.96	210.6	450.7
7%	22.43	69.81	167.9	369.5
8%	18.40	56.95	135.9	308.5
9%	15.27	46.94	111.0	261.1
10%	12.76	38.94	91.16	223.2
11%	10.71	32.39	74.87	192.2
12%	9.00	26.93	61.30	166.3
13%	7.55	22.31	49.82	144.5
14%	6.31	18.35	39.97	125.7
15%	5.24	14.92	31.44	109.5
16%	4.30	11.92	23.97	95.28
17%	3.47	9.277	17.39	82.73
18%	2.73	6.923	11.53	71.58
19%	2.07	4.817	6.298	61.60
20%	1.48	2.921	1.583	52.62

## 7. Input / Output Considerations

### 7.1 Input Capacitance at the Power Module

The converters must be connected to low AC source impedance. To avoid problems with loop stability source inductance should be low. Also, the input capacitors ( $C_{in}$ ) should be placed close to the converter input pins to de-couple distribution inductance. However, the external input capacitors are chosen for suitable ripple handling capability. Low ESR capacitors are good choice. Circuit as shown as below represents typical measurement methods for reflected ripple current.  $C1$  and  $L1$  simulate a typical DC source impedance. The input reflected-ripple current is measured by current probe to oscilloscope with a simulated source Inductance ( $L1$ ).

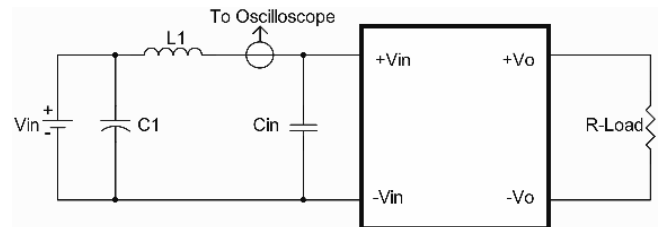

$L1$ : 12 $\mu$ H

$C1$ : 82 $\mu$ F ESR<0.7ohm @100KHz

$C_{in}$ : 82 $\mu$ F ESR<0.7ohm @100KHz

### 7.2 Hold Up Time

Hold up time is defined as the duration of time that DC/DC converter output will remain active following a loss of input power. To meet power supply interruptions, an external circuit is required, shown below.

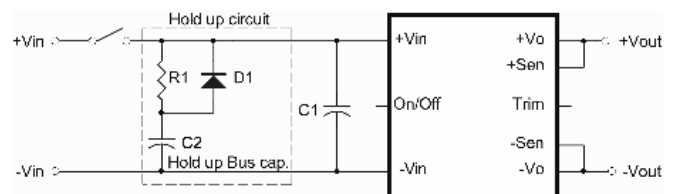

$D1$ : 200V/10A

$R1$ : 100 $\Omega$ /10W

$C1$ : 82 $\mu$ F/250V ESR<0.7 $\Omega$

$C2$	24Vin	36Vin	48Vin
Hold up time for 10ms	3300 $\mu$ F	1100 $\mu$ F	600 $\mu$ F
Hold up time for 30ms	9400 $\mu$ F	3300 $\mu$ F	1700 $\mu$ F
$C2$	72Vin	96Vin	110Vin
Hold up time for 10ms	250 $\mu$ F	150 $\mu$ F	120 $\mu$ F
Hold up time for 30ms	730 $\mu$ F	410 $\mu$ F	330 $\mu$ F



# CQB50W12 Series Application Note V12

## 7.3 Output Ripple and Noise

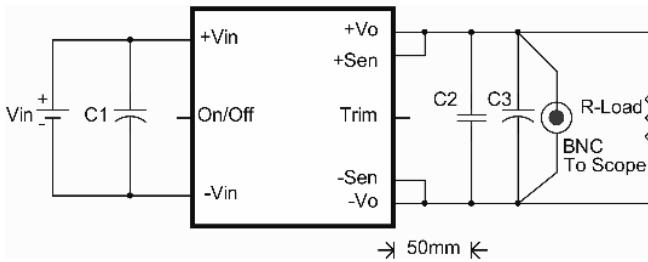

C1: 82uF/250V ESR<0.7Ω

C2: 1uF/1206 ceramic capacitor

C3: 22uF aluminum solid capacitor

Output ripple and noise measured with 22uF aluminum solid and 1uF ceramic capacitors across output. A 20 MHz bandwidth oscilloscope is normally used for the measurement.

The conventional ground clip on an oscilloscope probe should never be used in this kind of measurement. This clip, when placed in a field of radiated high frequency energy, acts as an antenna or inductive pickup loop, creating an extraneous voltage that is not part of the output noise of the converter.



Another method is shown in below, in case of coaxial-cable/BNC is not available. The noise pickup is eliminated by pressing scope probe ground ring directly against the -Vout terminal while the tip contacts the +Vout terminal. This makes the shortest possible connection across the output terminals.

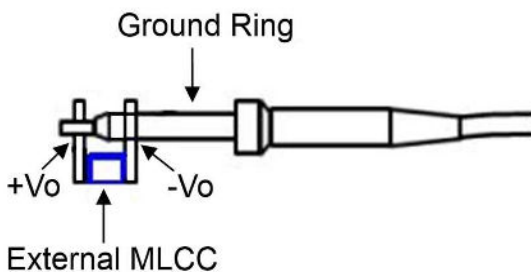

## 7.4 Output Capacitance

The CQB50W12 series converters provide unconditional stability with or without external capacitors. For good transient response, low ESR output capacitors should be located close to the point of load (<100mm). PCB design emphasizes low resistance and inductance tracks in consideration of high current applications. Output capacitors with their associated ESR values have an impact on loop stability

and bandwidth. Cincon's converters are designed to work with load capacitance to see specifications.

## 8. Series and Parallel Operation

### 8.1 Series Operation

Series operation is possible by connecting the outputs two or more units. Connection is shown in below. The output current in series connection should be lower than the lowest rate current in each power module.

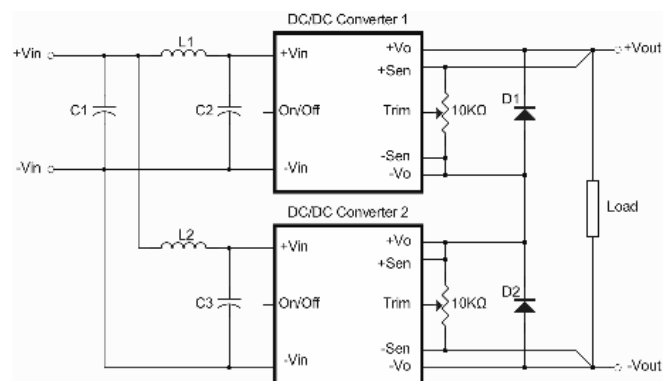

**Simple Series Operation Connect Circuit**

L1, L2: 1.0uH

C1, C2, C3: 82uF/250V ESR<0.7Ω

#### Note:

1. If the impedance of input line is high, C1, C2, C3 capacitance must be more than above. Use more than two recommended capacitor above in parallel when ambient temperature becomes lower than -20 °C.
2. Recommend Schottky diode (D1, D2) be connected across the output of each series connected converter, so that if one converter shuts down for any reason, then the output stage won't be thermally overstressed. Without this external diode, the output stage of the shut-down converter could carry the load current provided by the other series converters, with its MOSFETs conducting through the body diodes. The MOSFETs could then be overstressed and fail. The external diode should be capable of handling the full load current for as long as the application is expected to run with any unit shut down.



# CQB50W12 Series Application Note V12

Series for  $\pm$ output operation is possible by connecting the outputs two units, as shown in the schematic below.

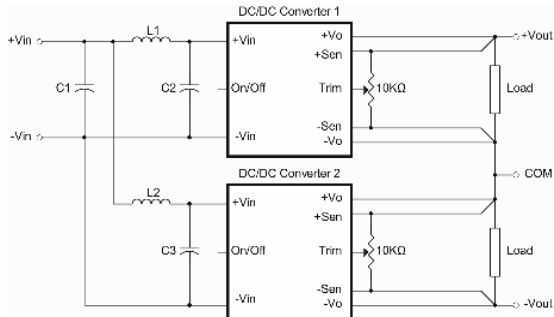

**Simple  $\pm$ Output Operation Connect Circuit**

L1, L2: 1.0uH

C1, C2, C3: 82uF/250V ESR<0.7 $\Omega$

**Note:**

If the impedance of input line is high, C1, C2, C3 capacitance must be more than above. Use more than two recommended capacitor above in parallel when ambient temperature becomes lower than -20  $^{\circ}$ C.

## 8.2 Parallel Operation

The CQB50W12 series parallel operation is **not** possible.

## 8.3 Redundant Operation

Parallel for redundancy operation is possible by connecting the units as shown in the schematic below. The current of each converter become unbalance by a slight difference of the output voltage. Make sure that the output voltage of units of equal value and the output current from each power supply does not exceed the rate current. Suggest use an external potentiometer to adjust output voltage from each power supply.

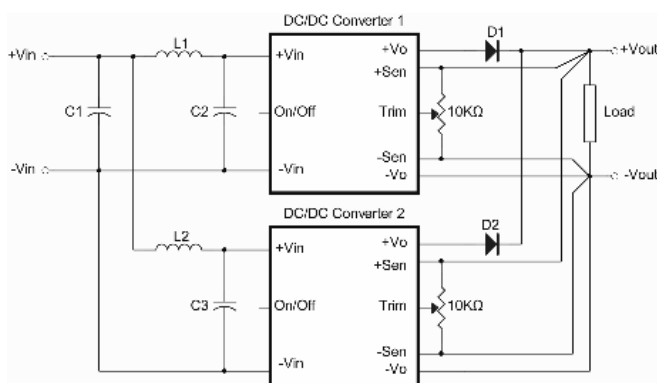

**Simple Redundant Operation Connect Circuit**

L1, L2: 1.0uH

C1, C2, C3: 82uF/250V ESR<0.7 $\Omega$

**Note:**

If the impedance of input line is high, C1, C2, C3 capacitance must be more than above. Use more than two recommended capacitor above in parallel when ambient temperature becomes lower than -20  $^{\circ}$ C.



# CQB50W12 Series Application Note V12

## 9. Thermal Design

### 9.1 Operating Temperature Range

The CQB50W12 series converters can be operated within a wide case temperature range of -40°C to 100°C. Consideration must be given to the derating curves when ascertaining maximum power that can be drawn from the converter. The maximum power drawn from open quarter brick models is influenced by usual factors, such as:

- Input voltage range
- Output load current
- Forced air or natural convection
- Heat sink optional

### 9.2 Convection Requirements for Cooling

To predict the approximate cooling needed for the quarter brick module, refer to the power derating curves in **section 9.4**. These derating curves are approximations of the ambient temperatures and airflows required to keep the power module temperature below its maximum rating. Once the module is assembled in the actual system, the module's temperature should be monitored to ensure it does not exceed 100°C as measured at the center of the top of the case (thus verifying proper cooling).

### 9.3 Thermal Considerations

The power module operates in a variety of thermal environments; however, sufficient cooling should be provided to help ensure reliable operation of the unit. Heat is removed by conduction, convection, and radiation to the surrounding environment. The example is presented in **section 9.4**. The power output of the module should not be allowed to exceed rated power ( $V_{o\_set} \times I_{o\_max}$ ).

### 9.4 Power Derating

The operating case temperature range of CQB50W12 series is -40°C to +100°C. When operating the CQB50W12 series, proper derating or cooling is needed. The maximum case temperature under any operating condition should not exceed 100°C.

The following curve is the de-rating curve of CQB50W12 series without heat sink.

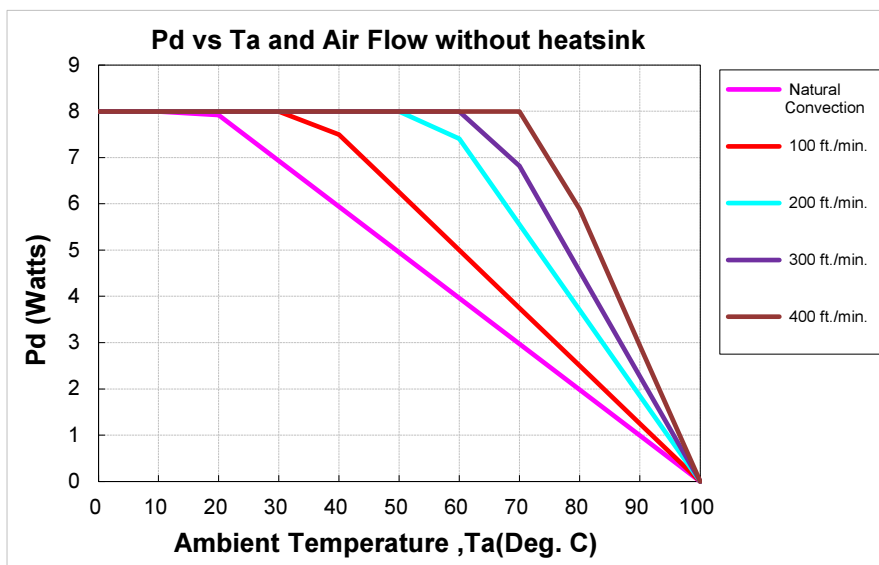

AIR FLOW RATE	TYPICAL $R_{ca}$
Natural Convection 20ft./min. (0.1m/s)	10.1 °C/W
100 ft./min. (0.5m/s)	8.0 °C/W
200 ft./min. (1.0m/s)	5.4 °C/W
300 ft./min. (1.5m/s)	4.4 °C/W
400 ft./min. (2.0m/s)	3.4 °C/W



# CQB50W12 Series Application Note V12

**Example:**

What is the minimum airflow necessary for a CQB50W12-72S12 operating at nominal line voltage, an output current of 4.2A, and a maximum ambient temperature of 40°C?

**Solution:**

**Given:**  $V_{in}= 72V_{dc}$ ,  $V_o= 12V_{dc}$ ,  $I_o= 4.2A$

**Determine Power dissipation ( $P_d$ ):**  $P_d= P_i-P_o= P_o(1-\eta)/\eta$ ,  $P_d= 12 \times 4.2 \times (1-0.87)/0.87= 7.53Watts$

**Determine airflow:** Given:  $P_d= 7.53W$  and  $T_a= 40^\circ C$

**Check Power Derating curve:** Minimum airflow= 200 ft./min.

**Verify:**

Maximum temperature rise is  $\Delta T= P_d \times R_{ca} = 7.53 \times 5.4= 40.67^\circ C$

Maximum case temperature is  $T_c = T_a + \Delta T= 80.67^\circ C < 100^\circ C$

**Where:**

The  $R_{ca}$  is thermal resistance from case to ambient environment.

$T_a$  is ambient temperature and  $T_c$  is case temperature.

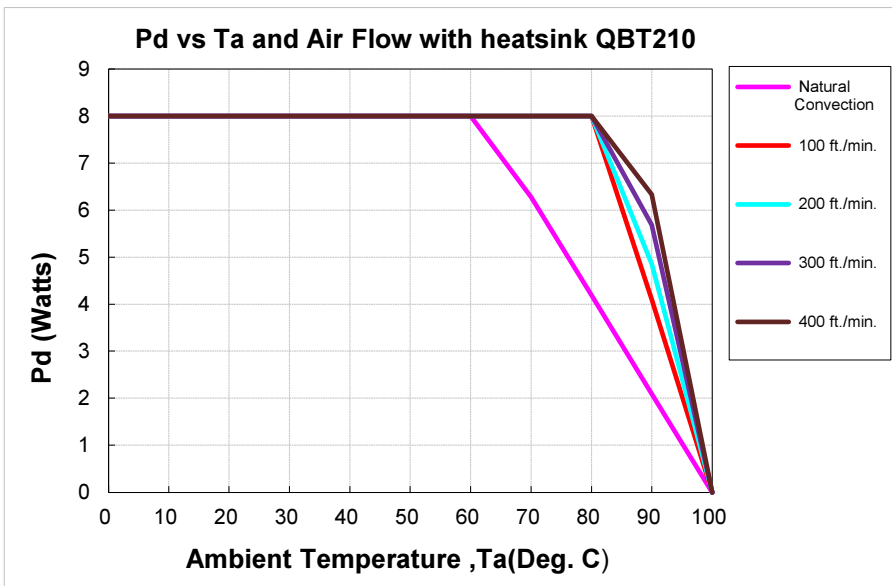

AIR FLOW RATE	TYPICAL $R_{ca}$
Natural Convection 20ft./min. (0.1m/s)	4.78 °C/W
100 ft./min. (0.5m/s)	2.44 °C/W
200 ft./min. (1.0m/s)	2.06 °C/W
300 ft./min. (1.5m/s)	1.76 °C/W
400 ft./min. (2.0m/s)	1.58 °C/W

**Example with heat sink QBT210 (M-C421):**

What is the minimum airflow necessary for a CQB50W12-72S12 operating at nominal line voltage, an output current of 4.2A, and a maximum ambient temperature of 80°C?

**Solution:**

**Given:**  $V_{in}= 72V_{dc}$ ,  $V_o= 12V_{dc}$ ,  $I_o= 4.2A$

**Determine Power dissipation ( $P_d$ ):**  $P_d= P_i-P_o= P_o(1-\eta)/\eta$ ,  $P_d= 12 \times 4.2 \times (1-0.87)/0.87= 7.53Watts$

**Determine airflow:** Given:  $P_d= 7.53W$  and  $T_a = 80^\circ C$

**Check above Power de-rating curve:** Minimum airflow= 100 ft./min

**Verify:**

Maximum temperature rise is  $\Delta T= P_d \times R_{ca}= 7.53 \times 2.44= 18.37^\circ C$

Maximum case temperature is  $T_c= T_a + \Delta T= 98.37^\circ C < 100^\circ C$

**Where:**

The  $R_{ca}$  is thermal resistance from case to ambient environment.

$T_a$  is ambient temperature and  $T_c$  is case temperature.



# CQB50W12 Series Application Note V12

## 9.5 Quarter Brick Heat Sinks:

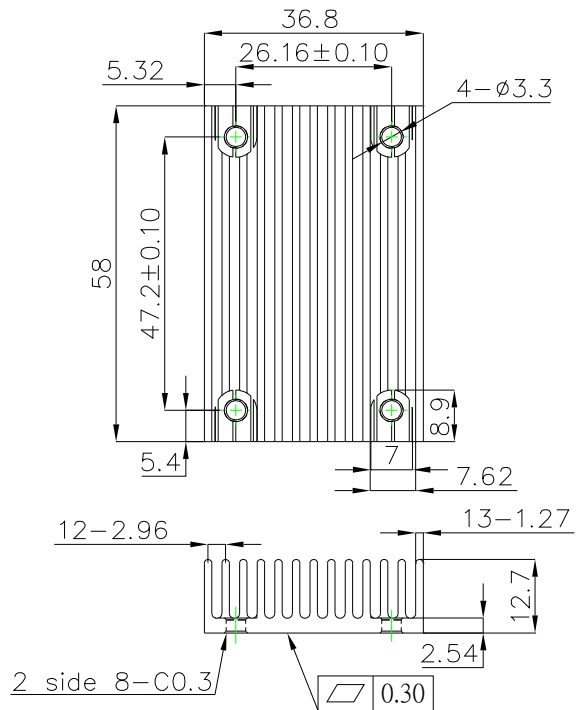
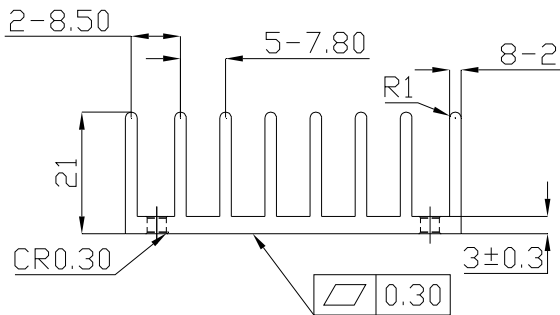
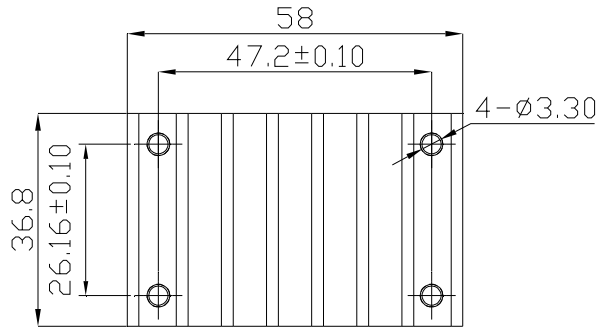

All Dimensions in mm

### QBT210 (M-C421) G6620510201 Transverse Heat Sink

Rca: 4.78°C/W (typ.), At natural convection  
2.44°C/W (typ.), At 100LFM  
2.06°C/W (typ.), At 200LFM  
1.76°C/W (typ.), At 300LFM  
1.58°C/W (typ.), At 400LFM

### QBL127 (M-C448) G6620570202 Longitudinal Heat Sink

Rca: 5.61°C/W (typ.), At natural convection  
4.01°C/W (typ.), At 100LFM  
3.39°C/W (typ.), At 200LFM  
2.86°C/W (typ.), At 300LFM  
2.49°C/W (typ.), At 400LFM

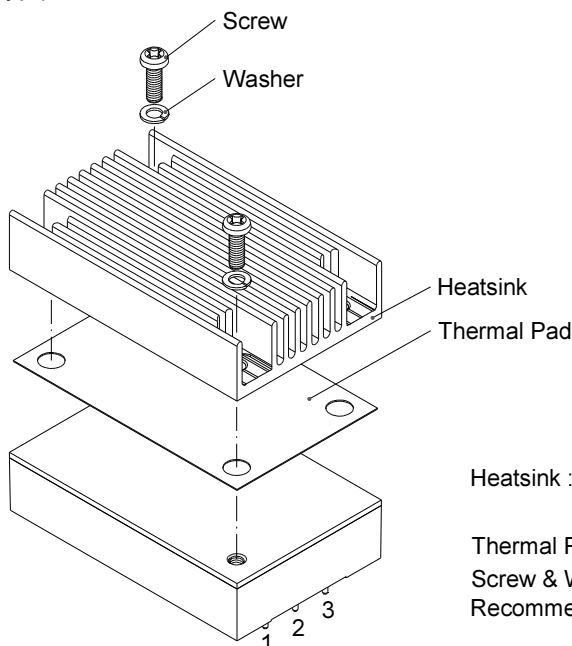

Heatsink : QBL127 (M-C448)  
QBT210 (M-C421)

Thermal Pad PQ01: SZ35.8x56.9x0.25mm  
Screw & Washer K308W: M3x8L & WS3.2N  
Recommended torque 3 Kgf-cm



# CQB50W12 Series Application Note V12

## 10. Safety & EMC

### 10.1 Input Fusing and Safety Considerations

The CQB50W12 series converters have no internal fuse. In order to achieve maximum safety and system protection, always use an input line fuse. We recommended a 6A time delay fuse for all models. It is recommended that the circuit have a transient voltage suppressor diode (TVS) across the input terminal to protect the unit against surge or spike voltage and input reverse voltage (as shown).

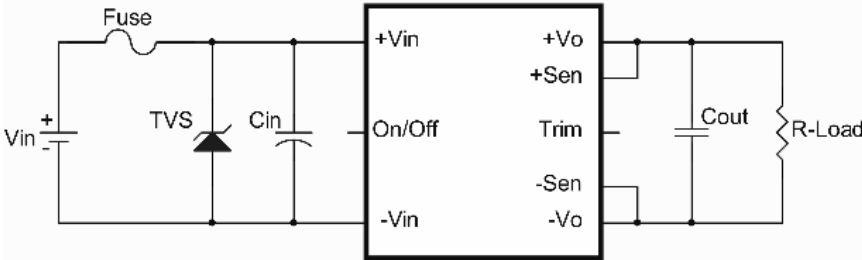

The external input capacitor ( $C_{in}$ ) and transient voltage suppressor diode (TVS) are required if CQB50W12 series has to meet EN61000-4-4, EN61000-4-5.

The  $C_{in}$  recommended a 82uF/250V (Nippon Chemi-Con KY series) aluminum capacitor. And the TVS recommended a SMDJ180A transient voltage suppressor.

### 10.2 EMC Considerations

- (1) EMI Test standard: EN55032 Class A/EN50121-3-2 Conducted & Radiated Emission  
Test Condition: Input Voltage: 110Vdc, Output Load: Full Load

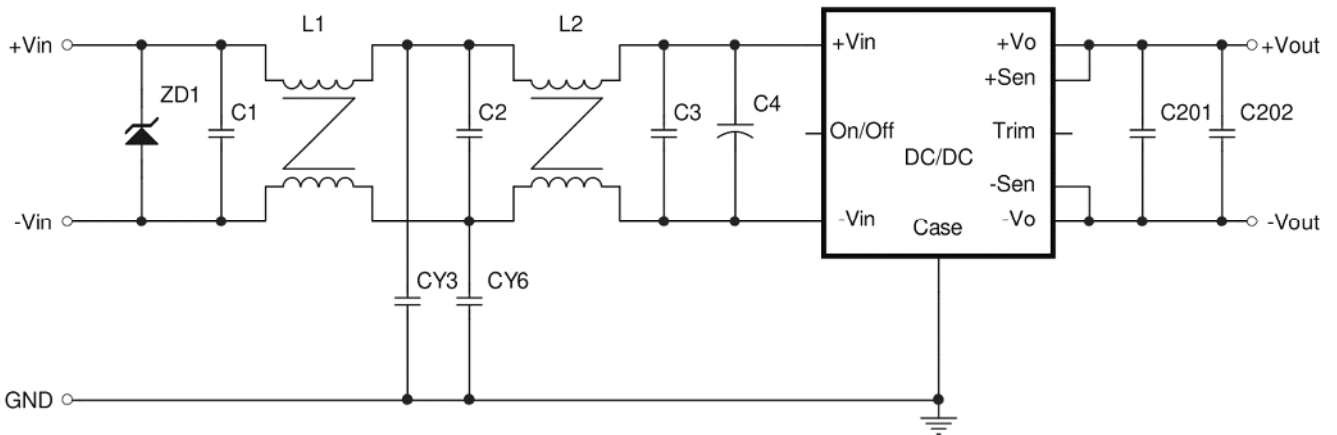

Figure1 Connection circuit

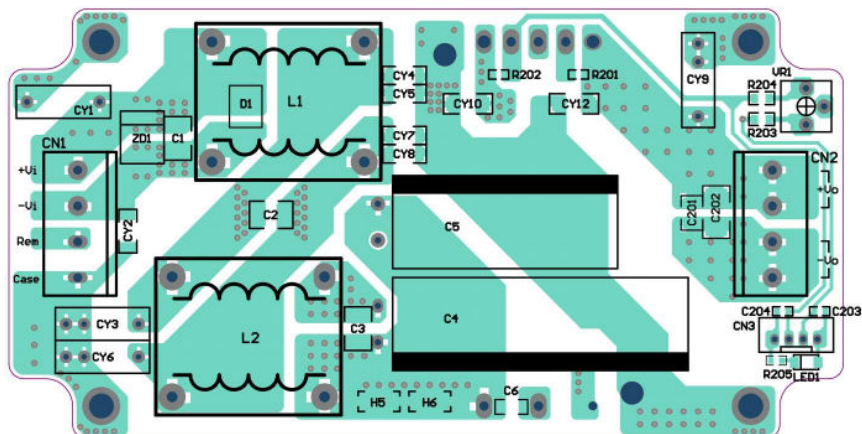

Figure2 PCB layout top view



# CQB50W12 Series Application Note V12

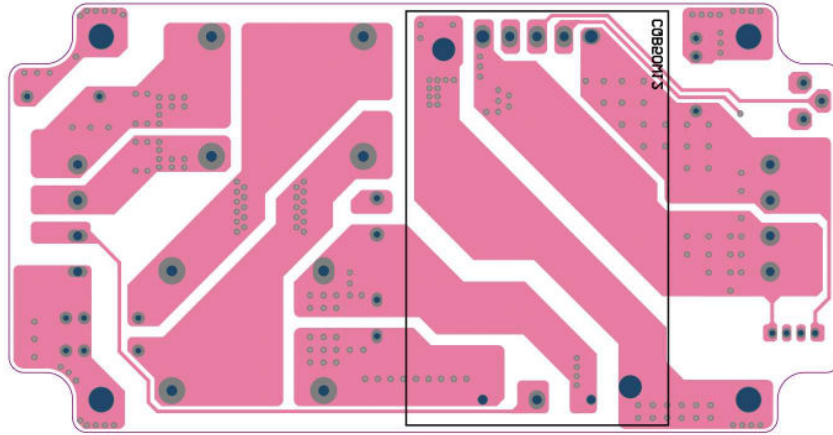

Figure3 PCB layout bottom view

### Components value:

DC/DC	Model number			
	72S05	72S12	72S24	72S48
C1, C2, C3	1uF/250V, 1812 MLCC			
C4	82uF/250V, Aluminum Cap. KXJ series			
C201	2.2uF/100V, 1210 MLCC			
C202	4.7uF/100V, 1812 MLCC			
CY3, CY6	1500pF/Y1			
ZD1	SMDJ180A			
L1, L2	URT24-050055H 5.5mH			

### Note:

C1, C2, C3: 1812 X7R ceramic.

C4: NIPPON CHEMI-CON KXJ series aluminum capacitor.

C201: 1210 X7R ceramic.

C202: 1812 X7R ceramic.

CY3, CY6: TDK Y1 capacitor or equivalent.

ZD1: SMDJ180A, SECOS

L1, L2: URT24-050055H, BULL WILL (G91C7221622) or equivalent.



# CQB50W12 Series Application Note V12

## Conducted Emission (Input):

CQB50W12-72S05

Line

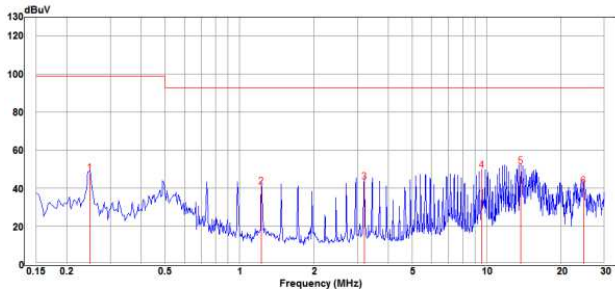

Neutral

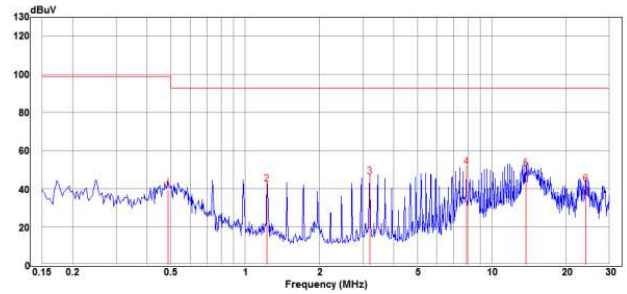

CQB50W12-72S12

Line

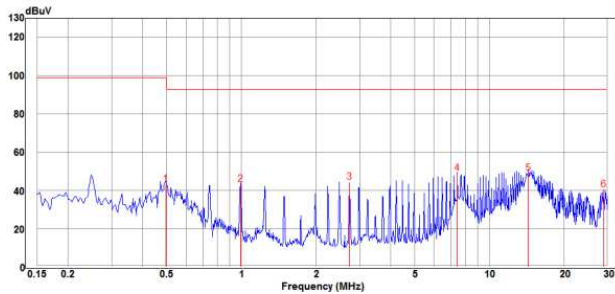

Neutral

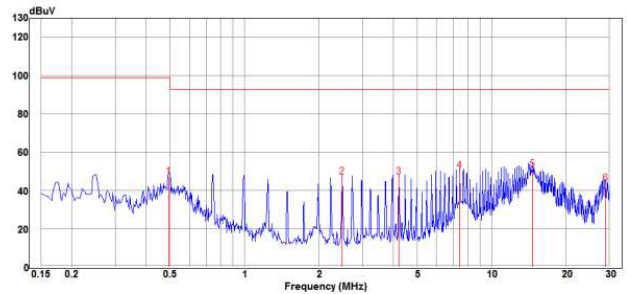

CQB50W12-72S24

Line

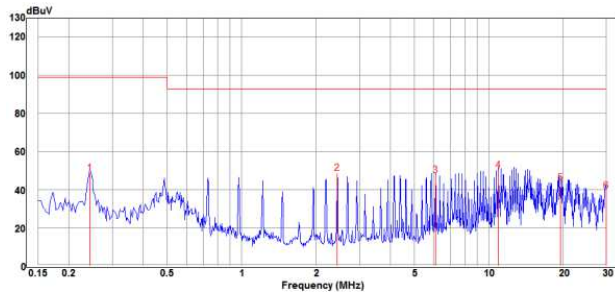

Neutral

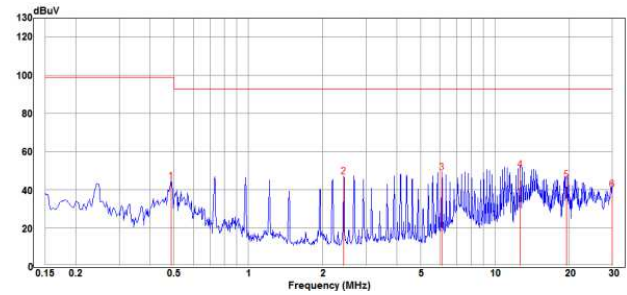

CQB50W12-72S48

Line

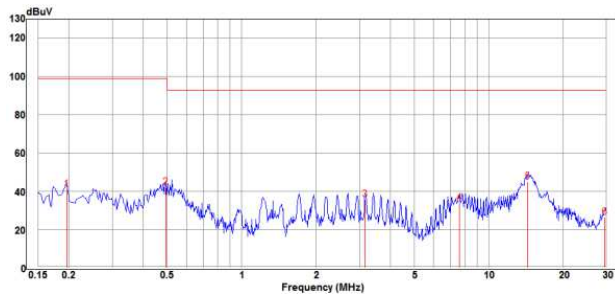

Neutral

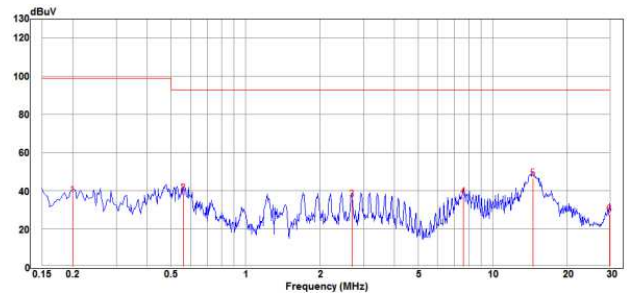



# CQB50W12 Series Application Note V12

## Radiated Emission:

CQB50W12-72S05

Vertical

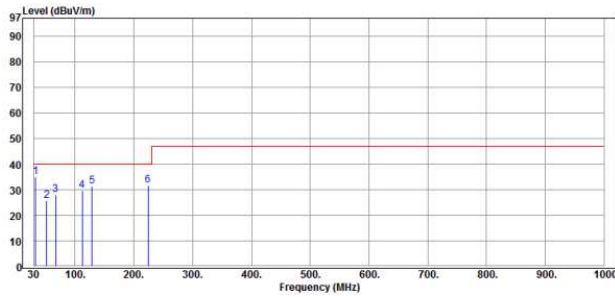

Horizontal

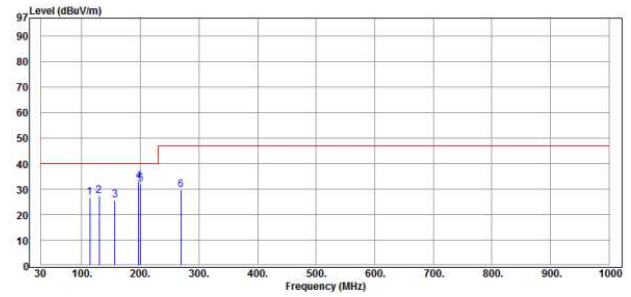

CQB50W12-72S12

Vertical

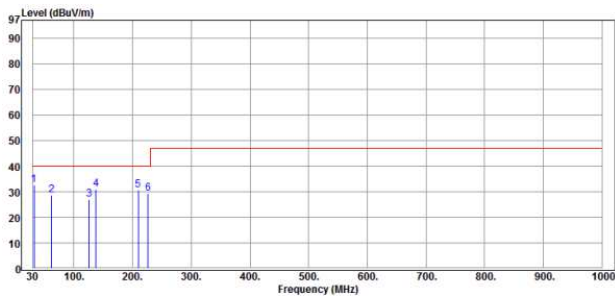

Horizontal

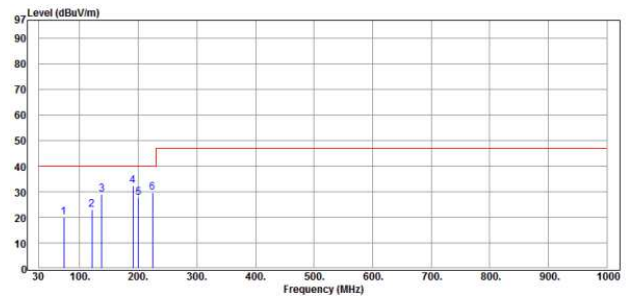

CQB50W12-72S24

Vertical

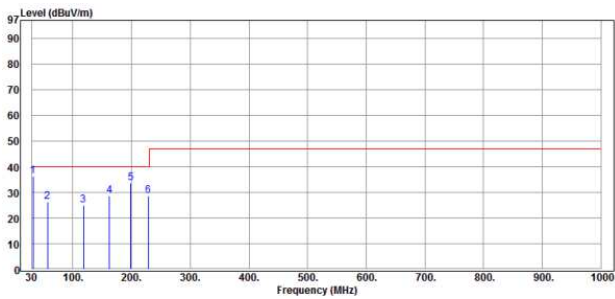

Horizontal

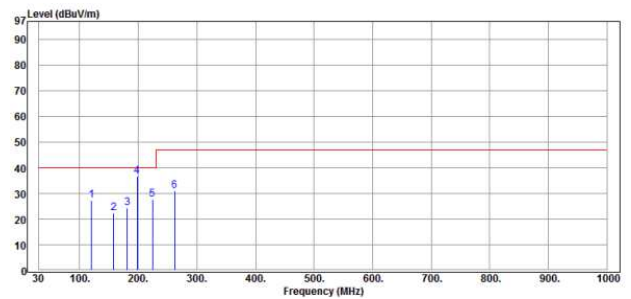

CQB50W12-72S48

Vertical

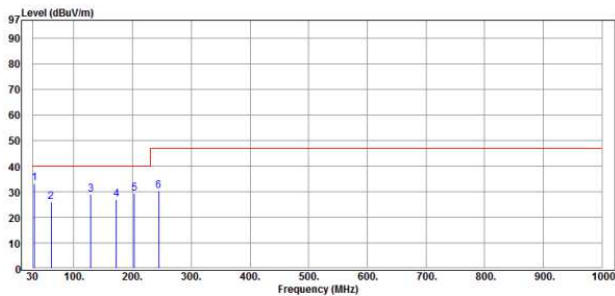

Horizontal

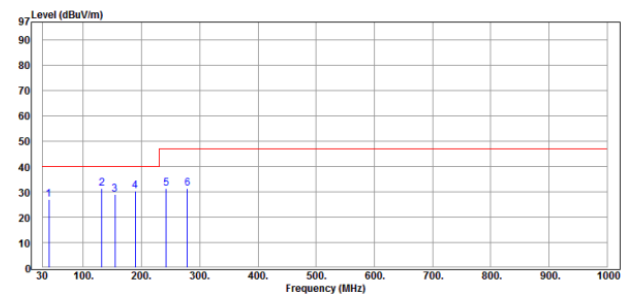



# CQB50W12 Series Application Note V12

(2) EMI Test standard: EN50121-3-2:2016 Output Conducted  
Test Condition: Input Voltage: 110Vdc, Output Load: Full Load

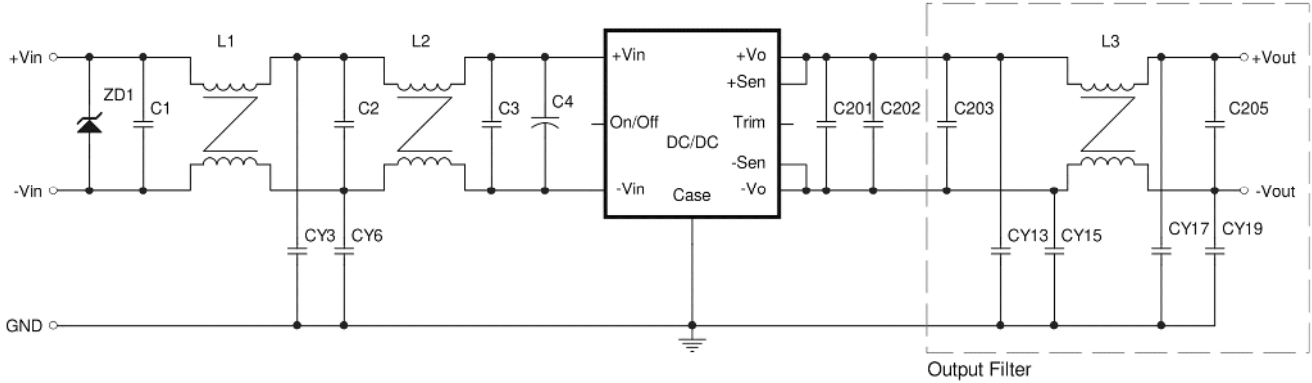

Figure4 Connection circuit

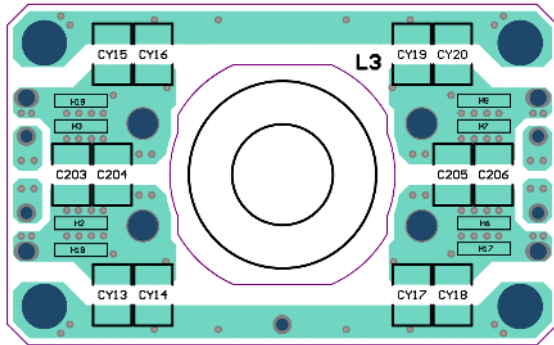

Figure5 Output Filter PCB layout top view

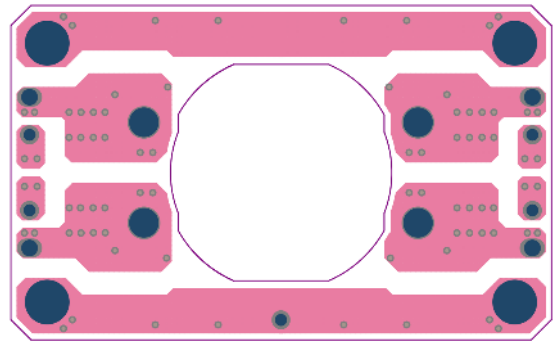

Figure6 Output Filter PCB layout bottom view

## Components value:

DC/DC	Model number			
	72S05	72S12	72S24	72S48
C1, C2, C3	1uF/250V, 1812 MLCC			
C4	82uF/250V, Aluminum Cap. KXJ series			
C201	2.2uF/100V, 1210 MLCC			
C202	4.7uF/100V, 1812 MLCC			
C203, C205	2.2uF/100V, 1210 MLCC			
CY3, CY6	1500pF/Y1			
CY13, CY15, CY17, CY19	0.047uF/1KV, 1812 MLCC			
ZD1	SMDJ180A			
L1, L2	URT24-050055H 5.5mH			
L3	Core P/N: CM15*10*4.5, Winding: 1.0mm*2 / 4Turns 0.4mH			

Note:

- C1, C2, C3: 1812 X7R ceramic
- C4: NIPPON CHEMI-CON KXJ series aluminum capacitor
- C201: 1210 X7R ceramic
- C202: 1812 X7R ceramic
- C203, C205: 1210 X7R ceramic
- CY3, CY6: TDK Y1 capacitor or equivalent
- CY13, CY15, CY17, CY19: 1812 X7R ceramic
- ZD1: SMDJ180A, SECOS
- L1, L2: URT24-050055H, BULL WILL (G91C7221622) or equivalent
- L3: Core CM15\*10\*4.5 or equivalent



# CQB50W12 Series Application Note V12

## Output Conducted Emission:

CQB50W12-72S05

Positive

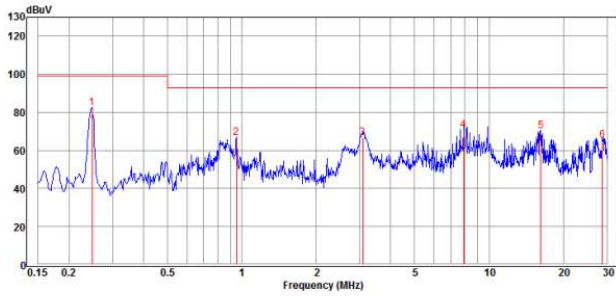

Negative

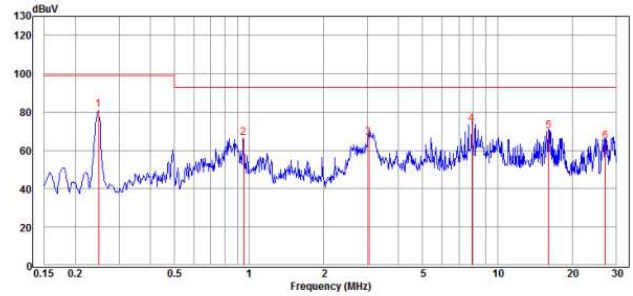

CQB50W12-72S12

Positive

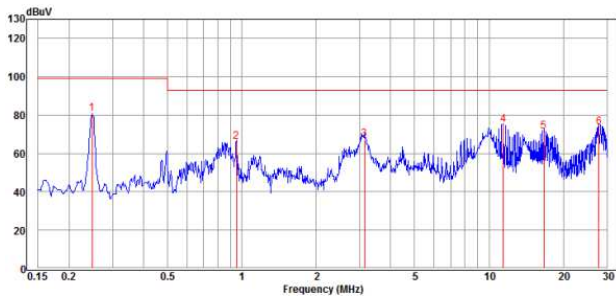

Negative

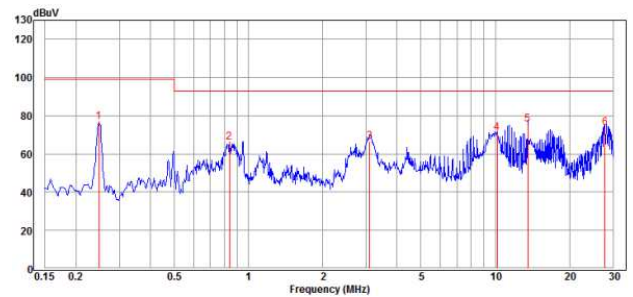

CQB50W12-72S24

Positive

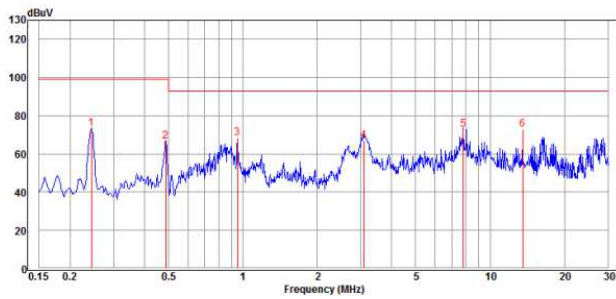

Negative

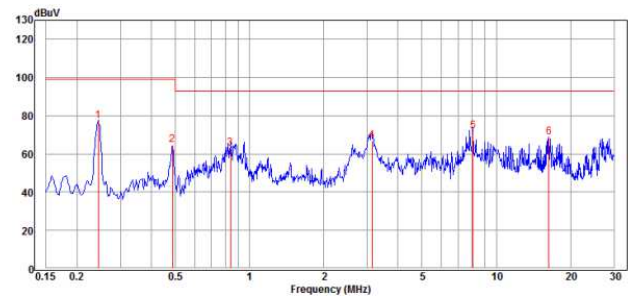

CQB50W12-72S48

Positive

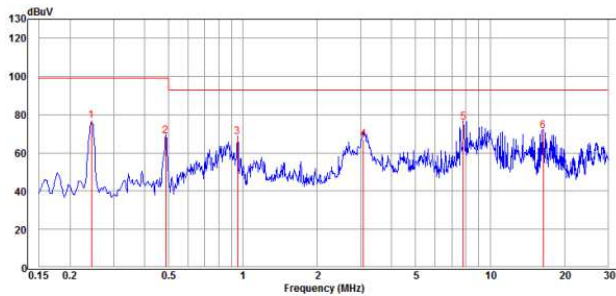

Negative

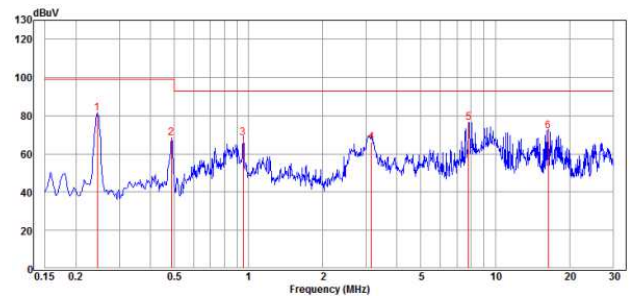



# CQB50W12 Series Application Note V12

## 10.3 Suggested Configuration for RIA12 Surge Test

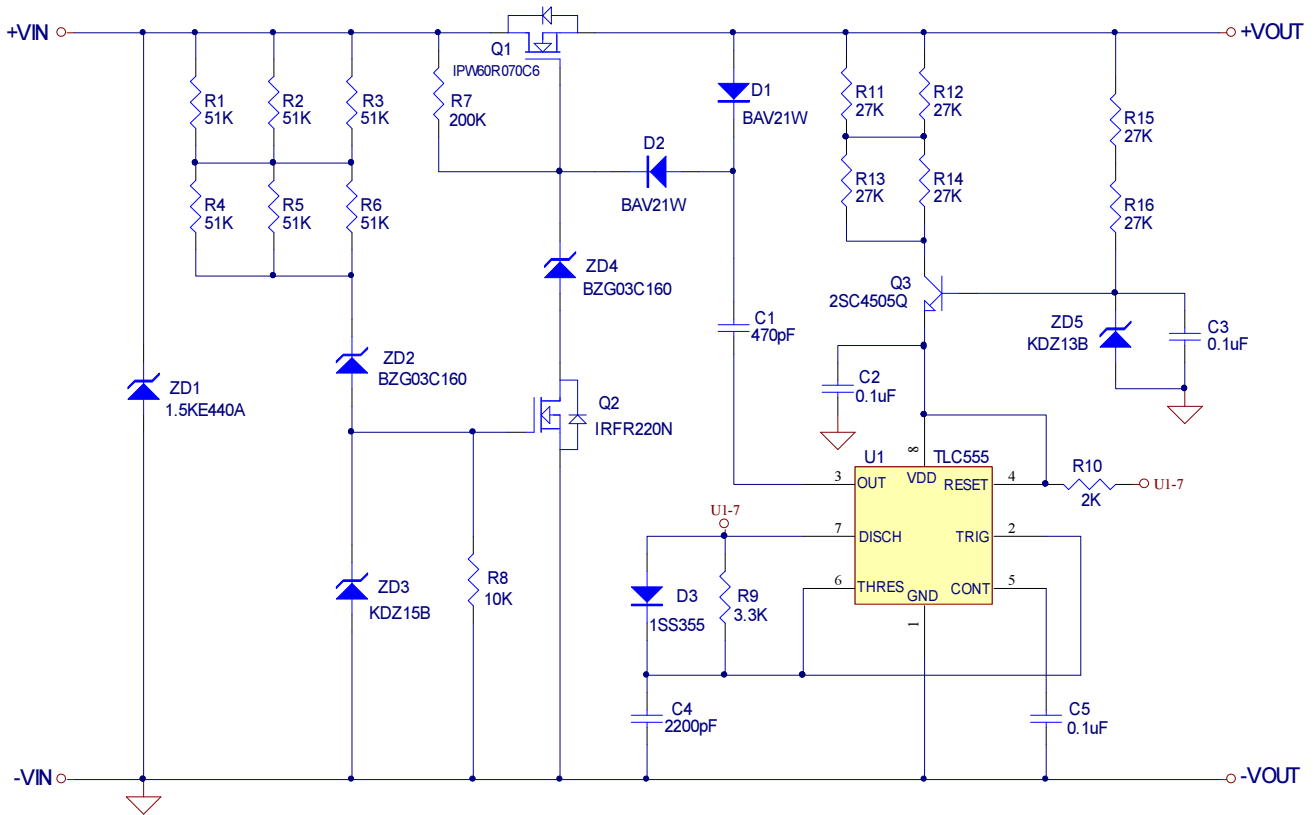

### CINCON ELECTRONICS CO., LTD.

#### Headquarters:

14F, No.306, Sec.4, Hsin Yi Rd.  
Taipei, Taiwan  
Tel: 886-2-27086210  
Fax: 886-2-27029852  
E-mail: [support@cincon.com.tw](mailto:support@cincon.com.tw)  
Web Site: <http://www.cincon.com>

#### Factory:

No. 8-1, Fu Kung Rd.  
Fu Hsing Industrial Park  
Fu Hsing Hsiang,  
ChangHua Hsien, Taiwan  
Tel: 886-4-7690261  
Fax: 886-4-7698031

#### Cincon North America:

1655Mesa Verde Ave. Ste 180  
Ventura, CA93003  
Tel: 805-639-3350  
Fax: 805-639-4101  
E-mail: [info@cincon.com](mailto:info@cincon.com)